

REQUEST FOR BIDS
Brownfields Cleanup and Floodplain Restoration
Former Woods Woolen Mill (NHDES Site No. 199909015)
23-25 West Mill Street
Hillsborough, New Hampshire

INTRODUCTION

This Request for Bids (RFB) has been prepared by Sanborn, Head & Associates, Inc. (Sanborn Head) for contracting bids for two separate contracts associated with Brownfields Cleanup and Floodplain Restoration at the Former Woods Woolen Mill property (the Site) located at 23-25 West Mill Street in Hillsborough, New Hampshire. Contractors interested in responding to this RFB **will be responsible for providing two separate Bids**; one for each contract. Contractor's who only provide bids for one contract will not be considered for selection.

The attached Bid Package details the scope of the two separate contracts, with a summary provided below.

Remediation Contract – This contract will be between the Contractor and Sanborn Head and will include the remediation of the Former Woods Woolen Mill site as detailed in the attached Bid Package.

Restoration Contract – This contract will be between the Contractor and Steamworks PLLC and will include the restoration of the Contoocook River floodplain, as detailed in the attached Bid Package.

Both contracts are anticipated to begin in the Spring 2026 and work for both contracts may be completed simultaneously.

Bids should be prepared and provided electronically to the following:

Remediation Bid

Heidi Caprood
hcaprood@sanbornhead.com

Laura Pasquine
Laura.J.Pasquine@des.nh.gov

Restoration Bid

Joel Ballestero
jballestero@streamworkspllc.com

Laura Buono
Laura@hillsboroughnh.net

BID WALK AND SCHEDULING

A mandatory bid walk will occur on Monday, December 15 at 10:00 AM accompanied by representatives from Sanborn Head and Streamworks. Following the bid walk, bidders will have until 5:00 PM on Thursday, December 18 to submit questions, with bids for both contracts submitted no later than 5:00 PM on Friday, January 9.

TABLE OF CONTENTS

**Brownfields Cleanup
Former Woods Woolen Mill
23-25 West Mill Street, Hillsborough, New Hampshire
NHDES Site #: 199909015**

BIDDING REQUIREMENTS

Invitation to Bid
Instructions to Bidders
Bid Form
Bidders Information Form
Bid Schedule
Available Information

CONTRACTING

Notice of Award
Construction Agreement
Payment Bond
Performance Bond
Notice to Proceed
Contractor's Affidavit
Contractor's Release
Application for Payment
Change Orders
Certificate of Substantial Completion
Certificate of Authority
General Conditions
Supplemental Conditions

ATTACHMENTS

Construction Design Drawings
Technical Specifications

BIDDING REQUIREMENTS

Invitation To Bid

INVITATION TO BID
Brownfields Cleanup
Former Woods Woolen Mill
23-25 West Mill Street, Hillsborough, New Hampshire
NHDES Site #: 199909015

Separate and sealed Bids for the Brownfields cleanup of the Former Woods Woolen Mill site located in Hillsborough, New Hampshire will be received by Sanborn, Head & Associates, Inc. (Sanborn Head), the Engineer, by **Friday, January 9, 2026 at 5:00 PM**. A second Invitation to Bid has been issued by Streamworks PLLC for floodplain restoration for a portion of the site. Contractor will need to prepare a separate bid for Streamworks PLLC's Contract., Sanborn Head and Streamworks PLLC's Contracts are subject to the Drawings and Specifications prepared by the respective firms. Both Contracts will make up the entirety of the Project.

A Mandatory Pre-Bid Meeting associated with both Contracts will be held at the Work site on Monday, December 15, 2025, at 10:00 AM.

The Project has been split into two Contracts, each of which are being funded through separate sources. The Sanborn Head Contract that is the subject of this Invitation to Bid is being led by the New Hampshire Department of Environmental Services (NHDES) and funded through NHDES Brownfields Cleanup Grants. The Streamworks PLLC Contract covering floodplain restoration (under separate cover) is through the Town of Hillsborough (the Owner) and funded through NHDES Aquatic Resource Mitigation (ARM) Funding. The NHDES and the Owner are completing this work to promote future redevelopment of the Brownfields site.

The work being completed under Sanborn Head's Contract includes, but is not limited to, the following major items:

- Excavating select areas where lead, polycyclic aromatic hydrocarbon (PAH), and antimony-impacted soils that exceed the NHDES Soil Remediation Standards (SRS) remain on-Site;
- Transporting and disposing of the following waste streams at appropriately permitted, Sanborn Head-approved, off-site disposal facilities: wood and vegetation from grubbing activities, impacted soils from the remedial excavation areas, and accumulated sediment and silt logs;
- Construction of a soil and/or rock cap to cover areas where lead, arsenic, chromium, and/or PAH-impacted soils remain in place within the Warehouse Building #2 area and within the former Dye House area;
- Soil caps will be constructed using soil and/or rock from Sanborn Head-approved on-site areas or with imported, off-site, clean fill materials if on-site material is not deemed suitable for reuse; and
- Decontaminating equipment and vehicles used for this project prior to leaving work areas or the site.

The Bid package includes a Bid Schedule for the Work completed under Sanborn Head's Contract. For the purposes of the bid, assume that the work will begin in Spring 2026.

Floodplain restoration work by Streamworks PLLC is expected to be performed concurrently with remedial activities. A separate Bid Schedule associated with the floodplain restoration work will be required as part of Streamworks PLLC Contract.

Following the Pre-Bid Meeting, should a Bidder wish to re-visit the site to verify conditions, or in the event they missed the Pre-Bid Meeting, the Bidder may make such a request to Sanborn Head, provided that the request is made in writing. All site visits pertaining to Sanborn Head's Contract should be coordinated through Sanborn Head.

As a federally funded project, compliance is required with the federal Building America, Buy America Act.

Each Bid must be accompanied by a Certificate of Existence from the New Hampshire Secretary of State.

No Bidder may withdraw a Bid within 60 calendar days after the actual date of opening thereof.

The successful Bidder must furnish 100% Performance and Payment Bonds with a surety company acceptable to Sanborn Head. The successful Bidder will be required to execute the Contract Agreement within 10 business days following notification of the acceptance of his Bid.

Sanborn Head reserves the right to waive any informality in, or to reject any or all Bids, if deemed to be in the best interest of the Owner.

Time required for the Contractor to achieve substantial completion for the project will be within 60 calendar days from the date of mobilization, which shall be in Spring 2026.

Liquidated damages for substantial completion of the work will be in the amount of \$1,500.00, made payable to Sanborn, Head & Associates, Inc., for each calendar day of delay from the date established for substantial completion.

All questions regarding this Bid should be directed to Sanborn Head:

Heidi Caprood, P.E. (Sanborn Head)

hcaprood@sanbornhead.com

603-415-6149

Instructions To Bidders

INSTRUCTIONS TO BIDDERS

**Brownfields Cleanup
Former Woods Woolen Mill
23-25 West Mill Street, Hillsborough, New Hampshire
NHDES Site #: 199909015**

Bids will be received by Sanborn, Head & Associates, Inc. (herein called the “Engineer” or “Sanborn Head”) until **Friday, January 9, 2026 at 5:00 PM**. Contractor will need to prepare a separate bid for Streamworks PLLC’s Contract which includes floodplain restoration for a portion of the site, with both Sanborn Head and Streamworks PLLC’s Contracts being subject to the Drawings and Specifications prepared by the respective firms.

Bids for the remediation contract must be submitted electronically via email to Laura Pasquine at Laura.J.Pasquine@des.nh.gov (NHDES), and Heidi Caprood at hcaprood@sanbornhead.com (Engineer). The email must be received by the time indicated above. Bids received by email after this time will not be accepted.

All Bids must be made on the required Bid Form. All blank spaces for Bid prices must be filled in, in ink or typewritten, and the Bid form must be fully completed and executed when submitted.

Sanborn Head may waive any informalities or minor defects or reject any and all Bids. Any Bid may be withdrawn prior to the above scheduled time for the opening of Bids or authorized postponement thereof. Any Bid received after the time and date specified shall not be considered. No Bidder may withdraw a Bid within 60 days after the actual date of the opening thereof. Should there be reasons why the contract cannot be awarded within the specified period.

Bidders must satisfy themselves of the accuracy of the estimated quantities in the Bid Schedule by examination of the site and a review of the Construction Design Drawings and Technical Specifications including Addenda. After Bids have been submitted, Bidder shall not assert that there was a misunderstanding concerning the quantities of Work or of the nature of the Work to be done.

All questions about the meaning or intent of the Contract Documents shall be submitted to Sanborn Head in writing via email **by 5PM on December 18, 2025**. All replies that alter the intent of the Contract Documents will be issued by Addenda electronically delivered to all parties attending the Pre-Bid Meeting, and will be posted on the Town’s website **on December 22nd**.

Should a Bidder find discrepancies in and/or omissions from the Contract Documents or should a Bidder be in doubt as to their meaning, they shall notify Sanborn Head in writing via email **by 5PM on December 18th**. All replies that alter the intent of the Contract Documents will be issued by Addenda electronically delivered to all parties attending the Pre-Bid Meeting, and will be posted on the Town’s website **on December 22nd**.

The Contract Documents contain the provisions required for the construction of the Work. Information obtained from an officer, agent, or employee of Sanborn Head or any other person shall not affect the risks or obligations assumed by Contractor or relieve them from fulfilling any of the conditions of the Contract Documents.

A Performance Bond and a Payment Bond, each in the amount of 100 percent of the Contract Price, with a corporate surety approved by Sanborn Head, will be required for the faithful performance of the contract.

Attorneys-in-fact who sign Payment Bonds and Performance Bonds must file with each Bond a certified and effective dated copy of their power of attorney.

Within seven (7) calendar days from the date when Notice of Award is delivered to Bidder, the party to whom the contract is awarded will be required to deliver to Sanborn Head the executed Agreement and the Performance Bond and Payment Bond. The Notice of Award shall be accompanied by the necessary Agreement and Bond forms.

The Notice to Proceed shall be issued within seven (7) days execution of the Agreement between Contractor and Sanborn Head. Should there be reasons why the Notice to Proceed cannot be issued within such period, the time may be extended by mutual agreement between Sanborn Head and Contractor. If the Notice to Proceed has not been issued within the seven (7) day period or within the period mutually agreed upon, Contractor may terminate the Agreement without further liability on the part of either party.

Sanborn Head may make such investigations as deemed necessary to determine the ability of Bidder to perform the Work, and Bidder shall furnish to Sanborn Head all such information and data for this purpose as Sanborn Head may request. Sanborn Head reserves the right to reject any Bid if the evidence submitted by, or investigation of, such Bidder fails to satisfy Sanborn Head that such Bidder is properly qualified to carry out the obligations of the Agreement and to complete the Work contemplated therein.

Sanborn Head may reject any bid not prepared and submitted in accordance with the provisions hereof and may waive any informalities or reject any and all bids deemed to be in the best interest of Owner. Sanborn Head may also reject bids which in its sole judgment are incomplete, conditional, obscure or not responsive or which contain additions not called for, erasures not properly initialed, alterations, or similar irregularities; or Sanborn Head may waive such omissions, conditions or irregularities.

A conditional or qualified Bid will not be accepted. However, alternatives to required Bid Items will be considered as additional or alternate items provided they are in addition to responding to the required Bid Items.

All applicable laws, ordinances, and the rules and regulations of all authorities having jurisdiction over construction of the Project shall apply to the contract throughout.

Each Bidder is responsible for inspecting the site and for reading and being thoroughly familiar with the Contract Documents. The failure or omission of any Bidder to do any of the foregoing shall in no way relieve any Bidder from any obligation in respect to its Bid. Furthermore, the Bidder is responsible for ensuring the site foreman who will be overseeing implementation of the project fully understands the scope and details listed within the Construction Design Drawings and Technical Specifications prior to the start of construction.

Bidder shall supply the names and addresses of major material Suppliers and all Subcontractors when requested to do so by Sanborn Head.

MANDATORY PRE-BID MEETING

A Mandatory Pre-Bid Meeting will be held at the Former Woods Woolen Mill site located at 23-25 West Mill Street in Hillsborough, New Hampshire on Monday, December 15, 2025 at 10:00 AM. Representatives of Sanborn Head and Streamworks PLLC (separate Contract) will be present to discuss the Project. Information presented at the pre-Bid Meeting does not alter the Contract Documents.

Requests for interpretation of the Contract Documents at the Pre-Bid Meeting should be submitted in writing to the Sanborn Head. All questions that may alter the intent of the Contract Documents will be answered by Addenda, mailed or delivered to all parties attending the Pre-Bid Meeting, and posted on the Town's website.

FOLLOW-UP PRE-BID MEETINGS

Following the Pre-Bid Meeting, should a Bidder wish to visit the Work site to verify/confirm site conditions, or in the event they were unable to attend the Pre-Bid Meeting, Bidder may make such a request to Sanborn Head, provided that the request is made in writing. All site visits for Sanborn Head's Contract will be coordinated through Sanborn Head.

BIDDERS INFORMATION FORM

To demonstrate qualifications for the Contract, each Bidder must be prepared to submit written satisfactory evidence that they have sufficient experience, necessary capital, materials, machinery, and skilled workmen to complete the Contract. Sanborn Head's decision or judgment on these matters shall be final, conclusive, and binding.

To assist Sanborn Head in such investigations and determinations, Bidders will be required to submit to Sanborn Head a completed copy of Bidder's Information Form as part of the bid package. This form is available as part of these bound Contract Documents.

Financial statements to be submitted with Bidder's Information Form shall be of such date as Sanborn Head shall determine and shall include Bidder's latest balance sheet and income statement showing current assets, net fixed assets, other assets, current liabilities, and other liabilities.

BID FORM

Bid Forms must be completed in ink or typewritten. The Bid price of each item on the form must be stated in words and numerals. In case of a conflict, words will take precedence.

Bids by corporations must be executed in the corporate name by the president or vice president and corporate seal shall be affixed and attested to by the secretary. The corporate address and state of incorporation shall be shown below the signature.

All names must be typed or printed below the signature.

The Bid shall contain an acknowledgment of receipt of all Addenda.

CONTRACTOR EXPERIENCE

Contractor shall demonstrate that it and its subcontractor(s) have sufficient ability and the experience, financial capability, safety record and equipment necessary in this class of work, and sufficient capital, plant, and equipment to satisfactorily and successfully carry out the Work as shown and specified in the Contract Documents. As a minimum, Contractor must demonstrate it has successfully completed a minimum of three (3) projects of this type in the last five (5) years. Contractor shall submit the information required with the Bid. If Sanborn Head determines this submittal is incomplete, the Bid shall be considered incomplete and the Bid shall be rejected.

SUBCONTRACTORS

Contractor shall not award Work to Subcontractor(s) where the combined value of all subcontracted Work exceeds 50% of the Contract Price, not including transportation and disposal of remediation waste.

SAFETY AND HEALTH REGULATIONS

This project is subject to all of the Occupational Safety and Health Regulations (CFR 29 Part 1926, CFR 29 Part 1910.120, and all subsequent amendments) as promulgated by the U.S. Department of Labor on June 24, 1974. Contractors are urged to become familiar with the requirements of these regulations.

OVERHEAD, SURFACE AND SUB-SURFACE INVESTIGATIONS

The information presented in the Contract Documents was collected by Sanborn Head for their own use in preparing documents for the remediation of the site and for guidance in preparing engineering design and are shown on the plans and provided in the appendices. The accuracy and

completeness of the data is not guaranteed. Contractor is responsible for assuming all risk in any and all excavation Work. Contractor is required to examine the best sources available and visit the site to assure themselves of the project conditions.

INSURANCE

Contractor shall possess insurance in the types and limits described in the Contract Documents. Bidders shall provide sample Certificates of Insurance as part of the Bid Package and effective Certificates of Insurance upon notification of Contract Award. Said certificates shall name Owner (Town of Hillsborough), NHDES, and Engineer (Sanborn, Head & Associates, Inc., [Sanborn Head]) as additional insured parties and shall state that there are no pollution exclusions.

Failure of Bidder to provide confirmation of insurance coverage limits with their bid subjects bid to disqualification. Failure of Contractor to maintain the required insurance policies in force during the Work covered by the Contract Documents shall constitute a breach of the Contract, and Sanborn Head shall have the right, in addition to any other rights, to immediately cancel and terminate this agreement without further cost to Sanborn Head.

CONFLICT OF INTEREST

Contractor shall notify Sanborn Head of any actual, apparent, or potential conflict of interest regarding any individual working on a contract assignment or having access to information regarding the contract. This notification shall include both organizational conflicts of interest and personal conflicts of interest. If a personal conflict of interest exists, the individual who is affected shall be disqualified from taking part in any way in the performance of the assigned Work that created the conflict of interest situation.

COPIES OF THE CONTRACT

Executed copies of the Contract Documents will be distributed electronically to NHDES and Contractor by Sanborn Head.

NON-RESIDENT CONTRACTORS

The successful Bidder, if a corporation established under laws other than the State of New Hampshire, shall file, at the time of the execution of the contract, with Sanborn Head, notice of the name of its resident attorney, appointed as required by the laws of the State of New Hampshire.

The successful Bidder, if not a resident of New Hampshire, and not a corporation, shall file, at the time of execution of the contract, with Sanborn Head, a written appointment of a resident of the State of New Hampshire, having an office or place of business therein, to be their true and lawful attorney upon whom all lawful processes in any actions or proceedings against them may be served; and in such writing, which shall set forth said attorney's place of residence, shall agree that any lawful process against them which is served on said attorney shall be of the same legal force and validity as if served on them and that the authority shall continue in force so long as any liability

remains outstanding against them in New Hampshire. The power of attorney shall be filed in the office of the Secretary of State if required, and copies certified by the Secretary shall be sufficient evidence thereof. Such appointment shall continue in force until revoked by an instrument in writing, designating in a like manner some other person upon whom such processes may be served, which instrument shall be filed in the manner provided herein for the original appointment.

A Non-resident Contractor shall be deemed to be:

1. A person who is not a resident of the State of New Hampshire.
2. Any partnership that has no member thereof resident of the State of New Hampshire.
3. Any corporation established under laws other than those of the State of New Hampshire.

BIDDERS QUALIFICATIONS

No award will be made to any Bidder who cannot meet all of the following requirements:

1. Bidder shall not have defaulted nor turned the Work over to the bonding company on any contract within three years prior to the Bid date.
2. Bidder shall maintain a permanent place of business.
3. Bidder shall have adequate personnel and equipment to perform the Work expeditiously.
4. Bidder shall have suitable financial status to meet obligations incidental to the Work.
5. Bidder shall have appropriate technical experience satisfactory to Owner and Sanborn Head in the class of Work involved.
6. Bidder shall be registered with the Secretary of State to do business in New Hampshire.
7. Bidder shall not have failed to complete previous contracts on time, including approved time extensions.

INSURANCE CERTIFICATES

No Work will be permitted on the site until the required and current Insurance Certificates are supplied.

WITHDRAWAL OF BIDS

The attention of Bidders is directed to the fact that, in submitting their Bid, Bidder agrees that they will not withdraw their Bid within 60 consecutive calendar days after the actual date of the opening of Bids.

Prior to Bid opening, Bids may be withdrawn upon written or electronic request of Bidder provided confirmation of any electronic withdrawal over the signature of Bidder is placed in the mail and postmarked prior to the time set for Bid opening. Bid documents and security of any Bidder withdrawing their Bid in accordance with the foregoing conditions will be returned.

ADD-ON WORK

The attention of Bidders is directed to the fact that additional cleanup work tasks may be added to the Contract with the written approval of Sanborn Head and Contractor.

P:\4000s\4088.012\Source Files\Bid Documents\Procurement Documents\202511-Instructions.docx

Bid Form

BID FORM

**Brownfields Cleanup
Former Woods Woolen Mill
23-25 West Mill Street, Hillsborough, New Hampshire
NHDES Site #: 199909015**

To: **Sanborn, Head & Associates, Inc.** (hereinafter called "Engineer" or "Sanborn Head"):

Proposal of _____ (hereinafter called "Bidder"), organized and existing under the laws of the State of _____ doing business as _____
(Corporation, Partnership, Individual)

In compliance with your Advertisement, Bidder hereby proposes to perform all Work for the construction of: **Former Woods Woolen Mill Brownfields Cleanup** in strict accordance with the Contract Documents, within the time set forth therein, and at the prices presented in the Bid Schedule.

By submission of this Bid, each Bidder certifies, and in the case of a joint Bid each party thereto certifies as to their own organization, that this Bid has been arrived at independently, without consultation, communication, or agreement as to any matter relating to the Bid with any other Bidder or with any competitor.

Bidder hereby agrees to commence Work under this contract on or before a date to be specified in the Notice to Proceed and to complete the Project within 60 calendar days from the date specified in the "Notice to Proceed."

Liquidated damages for substantial completion of the work will be in the amount of \$1,500.00 for each calendar day of delay from the date established for substantial completion.

- A. The undersigned Bidder proposes and agrees, if this Bid is accepted, to enter into an agreement with Sanborn Head in the form included in the Contract Documents to perform and furnish all Work as specified or indicated in the Contract Documents for the Bid price and within the Bid times indicated in this Bid and in accordance with the other terms and conditions of the Contract Documents.
- B. Bidder accepts all of the terms and conditions of the Invitation to Bid and Instructions to Bidders. This Bid will remain subject to acceptance for ninety (90) days after the Notice of Award. Successful Bidder will sign and deliver the required number of counterparts of the Agreement with the Bonds and other documents required by the Bid requirements within seven (7) days after the date of Sanborn Head's Notice of Award.

C. In submitting this Bid, Bidder represents, as more fully set forth in the Agreement, that:

- a. Bidder has examined and carefully studied the Bid Documents and the following Addenda, receipt of which is hereby acknowledged: (List Addenda by Number and Date):

- b. Bidder has become familiar with and is satisfied as to the general, local and site conditions that may affect cost, progress, performance and furnishing of the Work.
- c. Bidder is familiar with and is satisfied as to all federal, state and local Laws and Regulations that may affect cost, progress, performance and furnishing of the Work.
- d. The submission of this Bid constitutes an incontrovertible representation by Bidder that without exception the Bid is premised upon performing and furnishing the Work required by the Contract Documents and such means, methods, techniques, sequences or procedures of construction as may be indicated in the Contract Documents, and that the Contract Documents are sufficient in scope and detail to indicate and convey understanding of all terms and conditions for performance and furnishing of the Work.
- e. Bidder has correlated the information known to Bidder, information and observations obtained from visits to the site, reports and drawings identified in the Contract Documents and all additional examinations, investigations, explorations, tests, studies and data with the Contract Documents.
- f. Bidder has given Sanborn Head written notice of all conflicts, errors, ambiguities or discrepancies that Bidder has discovered in the Contract Documents and the written resolution thereof by Sanborn Head is acceptable to Bidder, and the Contract Documents are generally sufficient to indicate and convey understanding of all terms and conditions for performing and furnishing the Work for which this Bid is submitted.
- g. This Bid is genuine and not made in the interest of or on behalf of any undisclosed person, firm or corporation and is not submitted in conformity with

any agreement rules of any group, association, organization or corporation; Bidder has not directly or indirectly induced or solicited any other Bidder to submit a false or sham Bid; Bidder has not solicited or induced any person, firm or corporation to refrain from bidding; and Bidder has not sought by collusion to obtain for itself any advantage over any other Bidder or over Sanborn Head.

- D. Bidder will complete the Work in accordance with the Contract Documents for the following Base Bid price:

TOTAL BASE BID PRICE

_____ dollars (\$ _____)
(words) *(figures)*

NOTE: Bids shall include sales tax and all other applicable taxes and fees.

- E. The Base Bid breakdown is set forth in the Bid Schedule. If increases or decreases in these quantities occur, the Contract Price is to be adjusted on the basis of the unit prices provided in the Schedule of Values. Bidder acknowledges that quantities of work are not guaranteed and final payment will be based on actual quantities determined as provided in the Contract Documents.
- F. Contractor shall furnish a 100 percent Performance Bond and a 100 percent Payment Bond each in the amount of the Lump Sum Base Bid.
- G. Bidder also proposes to perform alternate work as herein stated resulting in additions or deductions on the Base Bid proposal above and providing a breakdown of alternate prices in the Base Bid breakdown. Additions or deductions shall include the cost of modification of work or additional work that Bidder may be required to perform by reason of Sanborn Head's acceptance of the alternate.
- H. Bidder agrees that the Work will be substantially completed and ready for final payment on or before the date indicated in the Agreement.
- I. Bidder accepts the provisions of the Agreement as to liquidated damages in the event of failure to complete the Work within the time specified in the Agreement.

- J. The following documents are attached to and made a condition of this Bid:
 - a. A tabulation of Subcontractors, Suppliers and other persons and organizations required to be identified in this Bid.
 - b. Bid Schedule.
 - c. A photocopy of Contractor's License.
- K. Communications concerning this Bid shall be addressed to:

To:

Ms. Laura Pasquine
Laura.J.Pasquine@des.nh.gov

And:
Ms. Heidi Caprood
hcaprood@sanbornhead.com

- L. Terms used in this Bid which are defined in the General Conditions or Instructions, will have the meanings indicated in the General Conditions or Instructions.

SUBMITTED on _____, 20_____

State Contractor License No. _____(if applicable)

IF BIDDER IS:

An Individual

By _____
(Name)

doing business as _____

Business address: _____

Telephone No: _____

A Partnership

By _____
(Firm Name)

General Partner _____

(SEAL)

Business address: _____

Telephone No: _____

A Corporation

By _____
(Corporation Name)

Incorporated in the State of _____
(State of Incorporation)

(CORPORATE
SEAL)

By: _____
(Name of person authorized to sign)

(Title)

Attest: _____
(Secretary)

Business address: _____

Telephone No: _____

Date of Qualification to do Business is: _____

A Joint Venture

By _____
(Name 1)

Business address: _____

By _____
(Name 2)

Business address: _____

Official Communication Should Be Addressed to: _____

Telephone No: _____

(Each joint venturer must sign. The manner of signing for each individual, partnership and corporation that is a party to the joint venture should be in the manner indicated above).

Being duly sworn, _____
(Name) **deposes and says that he is of**

_____ **and that the answers to the foregoing**
(Company)

questions and all statements contained therein are true and correct.

Sworn to before me this _____ day of _____, 20 _____

By: _____
(Notary Public)

My Commission Expires: _____

Bidders Information Form

BIDDERS INFORMATION FORM

**Brownfields Cleanup
Former Woods Woolen Mill
23-25 West Mill Street, Hillsborough, New Hampshire
NHDES Site #: 199909015**

Bidder is requested to state below what Work of a similar character to that included in the proposed contract they have done to give references that will enable Sanborn Head to judge Bidder experience, skill, and business standing.

All questions must be answered and the data given must be clear and comprehensive. This statement must be notarized. If necessary, add separate sheets.

1. *Name of Bidder:* _____

2. *Permanent Main Office address:*

3. *When organized?* _____

4. *Where incorporated?* _____

5. *Is Bidder registered with the Secretary of the State to do business in New Hampshire?* ___(Yes) ___(No).

6. *How many years have you engaged in the contracting business under your present firm name?* _____

Also state names and dates of previous firm names, if any.

7. *General character of Work performed by your company:*

8. Have you ever failed to complete any Work awarded to you in the scheduled contract time, including approved time extensions? ___(Yes) ___(No).
If so, where and why?

9. Have you ever defaulted on a contract? ___(Yes) ___(No).
If so, where and why?

10. Have you ever had liquidated damages assessed on a contract?
___(Yes) ___(No). If so, where and why?

11. List the three (3) largest contracts executed by your company within the last three (3) years, stating approximate cost for each, and the month and year completed. Include references and points of contact.

12. *List three projects similar to the project in the last five years, stating approximate cost for each and the month and year completed, with references including point of contact:*

13. *List your major equipment available for this contract:*

14. *List your key personnel such as Project Superintendent and foreman available for this contract and attach their resume to this bid:*

15. *List any subcontractors and their scope whom you would expect to use for the project (unless this Work is to be done by your own organization):*

P:\4000s\4088.012\Source Files\Bid Documents\Procurement Documents\202511-BiddersInfoForm.docx

Bid Schedule

BID SCHEDULE

**Brownfields Cleanup
Former Woods Woolen Mill
23-25 West Mill Street, Hillsborough, New Hampshire
NHDES Site #: 199909015**

This Bid Schedule separates the Work associated with Sanborn Head's Contract portion of this Project into measurable units for payment purposes. A separate Bid Schedule associated with Streamworks PLLC's floodplain restoration Work will be prepared as part of their contract under separate cover.

Pay items shall be paid using the units and unit prices indicated on the Bid Schedule. Payment shall be full compensation for all labor, materials, services, equipment, tools, taxes, overhead and profit, transportation, and disposal required to complete the Work described under each pay item. Payment shall be made in accordance with the general terms and conditions of the Contract. Contractor shall be entirely responsible for performing all Work described in the Contract Documents, whether or not specifically or fully described on this Bid Schedule. For the purposes of the bid, assume that work will begin in Spring 2026.

Payment will not be made for quantities that exceed the stated quantities in the Bid Schedule, unless additional quantities are approved in writing by Engineer. Payment for lump sum items will be based on a percent complete basis, as determined by Engineer-approved contractor invoices for payment.

The following Bid Schedule shall be completed in ink or typewritten. The Bidder agrees to perform all the work described in Sanborn Head's Contract Documents for the following lump sum and unit prices.

BASE BID

PAY ITEM NO. AND DESCRIPTION		ESTIMATED QUANTITY		UNIT PRICE (\$/UNIT)		ITEM PRICE (\$)
1	Submittals and Permits	1	LS		LS	
2	Site Mobilization and Demobilization	1	LS		LS	
3	Erosion Control and Stabilization (Upland)	1	LS		LS	
4	Clearing, Grubbing, and Vegetation/Tree Removal	1	LS		LS	
5	Establish, Maintain, and Remove the Gravel Access Road, Decontamination Pad, and Perimeter Fencing	1	LS		LS	
6	Dust Control	1	LS		LS	
7	Excavation and Direct Loading of Soil from Excavations Areas 1 through 4	900	CY		CY	
8	Excavation and Temporary Stockpiling of Capping Material from Excavation Area 1	1	LS		LS	
9	Backfill of Excavation Areas 2 and 3	10	CY		CY	
10	Clean Soil/Rock Cap Installation					
10A.	Clean Soil and/or Rock Cap Placement, Grading, and Compaction	1	LS		LS	
10B.	Geotextile Marker Fabric	3,100	SF		SF	
11	Topsoil, Mulch, and Seed					
11A.	Topsoil for Soil Caps and Backfilled Areas	45	CY		CY	
11B.	Topsoil Placement and Tamping	1	LS		LS	
11C.	Mulch and Hydroseed	1	LS		LS	
12	Transportation and Disposal of Waste Items and Debris					
12A.	Impacted Soil from Excavation Areas 1 through 4 (Assumed Non-Hazardous Waste)	1,300	Ton		Ton	
12B.	Soil/Gravel from the Gravel Access Road and Decontamination Pad	1	LS		LS	
12C.	Erosion Control Features and Accumulated Sediment	1	LS		LS	
12D.	Stumps/Roots/Vegetation	1	Ton		Ton	
12E.	Miscellaneous Trash	1	LS		LS	
	Sub-Total Pay Item 12 – Waste Transport and Disposal	—	—		—	
	BASE BID TOTAL (Figures)					
	BASE BID TOTAL (Words)					
13	Contingency - Source and Transportation of 9-inch minimum rock for cap	20	CY		CY	

The Work to be done and paid for under any item shall not be limited to the exact extent mentioned or described herein, but rather, shall include all incidental work necessary or customarily needed for the completion of that item at no additional cost to Owner.

BID ITEM DEFINITIONS

ITEM 1: SUBMITTALS AND PERMITS

This item shall include the cost for preparation and completion of all submittals (refer to Section 01 33 00), and costs for obtaining permits and/or submitting necessary notifications applicable to the work, including payment of permit fees as needed. Determination of the permitting and notification requirements for the Work is the responsibility of Contractor. At a minimum, the permits and notifications anticipated to be required as part of Sanborn Head's Scope of Work include the NPDES Construction General Permit (CGP) Notice of Intent (NOI) and weekly inspections to be completed post-construction in accordance with the requirements of the Stormwater Pollution Prevention Plan (SWPPP) to be completed for the site under the CGP. Refer to Section 01 33 00 – Submittals Procedures for a list of required submittals. Required submittals include all close-out documentation.

Payment for this item will be made on a lump sum basis.

ITEM 2: SITE MOBILIZATION AND DEMOBILIZATION

This item shall include the cost for mobilization and demobilization of all equipment, materials, temporary facilities, and labor necessary to perform the Work. Specific work under this item shall also include:

- Clearance of underground utilities;
- Provision of temporary utilities and facilities (e.g., portable toilet);
- Installation of perimeter fencing and/or repairing the existing perimeter fencing as needed (refer to Section 01 50 00 – Temporary Facilities and Controls);
- Establishing vertical and horizontal control by subcontracting with a New-Hampshire licensed surveyor to layout proposed construction areas in accordance with the Design Drawings including, but not limited to: Excavation Areas, Cap Areas, staging areas, etc; and
- Clean-up of the site upon completion of work, including restoration of areas disturbed by the Work outside of the soil remediation areas.

All work required to comply with the health and safety specifications included in Section 01 35 29.13 – Health, Safety and Emergency Response Procedures for Contaminated Sites Specification, including preparation of the site-specific health and safety plan, shall be included in this task. Fifty percent of this payment item will be paid as part of the initial progress payment after all pre-construction submittals have been received and acknowledged by “No Exceptions Taken”, temporary support facilities are set up and construction equipment and

materials have been delivered to the site. The remainder will be paid for demobilization after Final Completion of the work has been approved by Engineer.

ITEM 3: EROSION CONTROL AND STABILIZATION (UPLAND)

This item requires Contractor to furnish all labor, equipment, and materials necessary to install and maintain erosion and sedimentation control devices in accordance with Section 01 57 13 – Temporary Erosion and Sediment Controls related to the Remediation portion of the Contract. Erosion and sediment controls shall be installed prior to clearing and grubbing activities.

This work includes the installation of filter logs in accordance with the Specifications and Drawings. Erosion and sediment control devices shall be maintained by Contractor throughout the course of construction activities with weekly inspection to see if maintenance of the features is required. If needed, accumulated sediment shall be removed when it reaches half the height of the exposed log, and stockpiled on at least 2 layers of 6-mil (0.006") polyethylene sheeting and covered by at least 1 layer of 6-mil polyethylene sheeting in accordance with Section 02 61 13 – Excavation and Handling of Contaminated Materials. After excavation and removal of impacted materials from the site and construction of the caps are completed and erosion and sediment control devices are no longer necessary, Contractor shall allow free access for Engineer to collect samples from accumulated sediment in the erosion and sediment control measures. Transportation and disposal of erosion controls and accumulated sediment is noted in Pay Item 12C. Erosion control measures associated with the floodplain restoration portion of the Work are covered under Streamworks PLLC Bid Schedule and should not be included under this Pay Item.

ITEM 4: CLEARING, GRUBBING, AND VEGETATION/TREE REMOVAL

This item requires Contractor to furnish all labor, equipment, and materials necessary to clear and grub the work area in accordance with the Drawings and Specifications. The Contractor shall remove from the site and transport to an approved facility any material generated during this item, which also includes invasive species such as Japanese Knotweed (refer to Section 31 11 00 – Clearing and Grubbing). Payment will be on a lump sum basis and will be made once the materials have been removed from the site. Costs for transportation and disposal of cleared stumps and vegetation are included in Pay Item 12D.

ITEM 5: ESTABLISH, MAINTAIN, AND REMOVE THE GRAVEL ACCESS ROAD AND DECONTAMINATION PAD

This item requires the Contractor to furnish all labor, equipment, and materials necessary to establish, maintain, and remove a gravel access road and decontamination pad as needed. The gravel access road and decontamination pad shall be constructed of crushed gravel as specified in Section 31 20 00 – Earth Moving, and in accordance with the Design Drawings.

A decontamination pad shall be constructed as part of the gravel access road for the purpose of decontaminating heavy equipment that may have come into contact with contaminated soil as described in the Specifications.

The work shall also include the removal of the temporary gravel access road and decontamination pad by the Contractor upon completion of construction activities and return of the area to its pre-construction conditions (refer to Section 02 61 013 – Excavation and Handling of Contaminated Materials). This item includes any physical laboratory testing needed for aggregate in accordance with the Specifications.

Payment will be on a lump sum basis. Fifty percent of this payment item will be paid as part of the initial progress payment after the gravel access road and decontamination pad are set up. The remainder will be paid when they are removed after Final Completion of the work has been approved by Sanborn Head. Payment for disposal of filter fabric and crushed gravel from the gravel access road and decontamination pad will be made under Pay Item 12B.

ITEM 6: DUST CONTROL

This item requires Contractor to furnish all labor, equipment, and materials necessary to minimize the creation of dust from the time of mobilization through demobilization. Volumes of water applied to control dust shall be minimized to decrease infiltration to contaminated soil in the subsurface. Misting dust control is recommended. Payment will be on a lump sum basis.

ITEM 7: EXCAVATION AND DIRECT LOADING OF IMPACTED SOIL FROM EXCAVATION AREAS 1 THROUGH 4

This item requires Contractor to furnish all labor, equipment, and materials necessary to excavate and direct-load impacted soils from Excavation Areas 1 through 4 in accordance with the Design Drawings. Excavated materials are to be direct loaded into dump trucks pending receiving facility approval. This item also includes Contractor's time associated with coordinating preparation of the waste profile form and facility approval. Receiving facilities will be approved by the Engineer prior to disposal. Engineer collected waste characterization samples and will provide results to the Contractor as part of the Bid Package. Further discussion of transportation and disposal of excavation materials is discussed in Pay Item 12.

Excavation Area 1 is estimated to consist of an average excavation thickness of 2.5-feet, impacted by PAHs and lead (typically below the NHDES SRS) totaling approximately 830 cubic yards (CY). The pesticide dieldrin was also detected in one of the pre-characterization soil samples. Impacted soil is located beneath capping material placed by USEPA and a geotextile fabric. Impacted soil from Excavation Area 1 will be excavated down to the subgrade needed for the floodplain restoration work and direct-loaded into dump trucks for off-site disposal presumably as non-hazardous waste for the cells where PAHs and dieldrin exceeded applicable standards (approximately 120 CY). The remaining approximately 710 CY is anticipated to go off-site as daily cover based on the pre-characterization data, but will need to be confirmed by the

receiving facility. Cover material placed by USEPA will be excavated by the Contractor under Pay Item 8.

Excavation Areas 2 and 3 will be excavated to depths of approximately 1 ft bgs each, with the volume of soil totaling approximately 10 CY between the two locations. Soils consist of lead and PAH-impacted soils and will be direct loaded into dump trucks for off-site disposal presumably as non-hazardous waste. Lead TCLP results in a pre-characterization soil sample collected by the Engineer from Excavation Area 3 indicate a concentration of 0.42 milligram/liter (mg/L), less than the standard of 5 mg/L, indicating the material is non-hazardous pending review by the receiving facility.

Excavation Area 4 will be excavated to a depth of approximately 2 ft bgs for a total of approximately 60 CY of lead-impacted soils. Soils will be direct loaded into dump trucks for off-site disposal presumably as non-hazardous waste, or daily cover, if approved by the receiving facility, based on pre-characterization soil data. If XRF screening performed by Sanborn Head indicates exceedances of SRS for lead, the excavation depth and size may be modified at Sanborn Head's discretion.

Sanborn Head will collect confirmatory samples for each of the Excavation Areas following excavation and XRF screening to confirm the targeted impacted material has been sufficiently removed. Backfilling for Excavations 2 and 3, and cap construction are included in Pay Items 8 and 9, respectively.

Payment for this Work Item will be on a cost per CY of soil excavated. Contractor will identify the actual quantity of soil removed by measuring the extent of the excavation and collecting weight slips and manifests from the receiving facilities, which will be provided to Sanborn Head.

ITEM 8: EXCAVATION AND TEMPORARY STOCKPILING OF COVER MATERIAL FROM EXCAVATION AREA 1

An approximately 1-foot-thick layer of cover material is located above the geotextile fabric overlying the impacted material in Excavation Area 1 (USEPA capping material). Soil samples collected by Sanborn Head indicated that the material is suitable to be reused on-site to construct the Former Warehouse Building #2 cap, the southern portion of the Northeast Former Dye House Area cap, and backfill for Excavation Areas 2 and 3. Excavation Areas 1 and 4 will not be backfilled as these areas will be reworked as part of Streamworks PLLC's floodplain restoration efforts.

Cover material removed from Excavation Area 1 can be temporarily stockpiled prior to backfilling and capping. Stockpiles shall be placed within the Former Warehouse #2 building foundation on 6-mil of polyethylene sheeting, or as directed by the Engineer. This item includes costs for the Contractor to furnish all labor, equipment, and materials necessary to excavate and temporarily stockpile the cover material. Cover material that is not able to be reused for

backfill or capping within the project limits will be disposed of under Streamworks PLLC restoration contract. Off-site disposal for this material is not included in this Pay Item. It is anticipated that approximately 430 CY of cover material is located in Excavation Area 1 and approximately 110 CY are needed for capping and backfilling.

Payment for this Work Item will be on a lump sum basis.

ITEM 9: BACKFILL OF EXCAVATION AREAS 2 AND 3

This item requires Contractor to furnish all labor, equipment, and materials necessary to transport, place, and compact approximately 10 CY of clean backfill in Excavation Areas 2 and 3, as indicated on the Drawings and Specifications. It is estimated that approximately 430 CY of clean soil is available to be reused from Excavation Area 1 from the capping material placed over the geotextile fabric. Additional clean backfill will be used if the size and depth of Excavation Areas are modified by Sanborn Head following XRF screening and confirmatory sampling. The installation of topsoil is covered under Pay Item 11. Payment for this Pay Item will be on a cost per CY basis.

ITEM 10: CLEAN CAP INSTALLATION

This item requires the Contractor to furnish all labor, equipment, and materials necessary to construct a clean soil cap in the Former Warehouse Building #2 area and southern portion of the Northeast Former Dye House Cap area and a rock cap in the northern portion of the Northeast Former Dye House Cap area, which are to be installed in accordance with the Drawings and Specifications. The Pay Item is broken into the following subtasks:

Item 10A: This item requires the Contractor to furnish all labor, equipment, and materials necessary to place, grade, and compact the clean soil cap over the Former Warehouse Building #2 area and the soil/rock cap over the Former Dye House area (i.e., soil on southern portion and rock on northern portion). Both caps are to be installed in accordance with the Drawings and Specifications. Granular fill shall be placed, graded, and compacted in accordance with the Specifications. This work includes, but is not limited to: water necessary for compaction of fill materials; and supply, placement, and compaction of clean fill and rock in accordance with the Drawings and Specifications. Cover material placed over the geotextile fabric in Excavation Area 1 shall be used as capping material. For the northern portion of the Northeast Former Dye House Cap area, it is anticipated that minimum 9-inch diameter rock removed from Excavation Area 1 as part of the floodplain restoration work can be used for construction of the cap. If 9-inch minimum rock is not encountered or is deemed not usable by the Engineer, the Contractor shall provide a source of material under contingency Pay Item 13. Payment for cap construction will be on a lump sum basis. Payment associated with rock excavation will be covered under Streamworks PLLC bid schedule.

Item 10B: This item requires the Contractor to furnish all labor, equipment, and materials necessary to install the geotextile marker fabric above the subgrade and below both the Former

Warehouse Building #2 and Former Dye House caps as shown on the Drawings and in accordance with the Specifications. If additional contamination is identified to remain in-place in Excavation Area 2, geotextile fabric will be placed prior to backfilling as directed by the Engineer. Payment for this line item will be per square-foot of fabric used.

ITEM 11: TOPSOIL, MULCH, AND SEED

This item requires the Contractor to furnish all labor, equipment, and materials necessary to restore disturbed areas including, but not limited to the capped areas, Excavation Areas, areas disturbed due to vehicle or equipment transport, grading activities, gravel access road, and staging areas. Topsoil associated with the construction of the floodplain restoration area will be covered separately under Streamworks PLLC's contract. The Pay Item is broken into the following subtasks:

Item 11A: This item requires the Contractor to furnish all labor, equipment, and materials necessary to provide topsoil material from a Sanborn Head-approved facility to the site. Payment for this Work Item will be on a per-cubic yard basis.

Item 11B: The Contractor shall place and tamp topsoil as shown on the Drawings and described in the Specifications. This includes any physical laboratory testing needed for topsoil in accordance with the Specifications. Payment for this Work Item will be on a lump sum basis.

Item 11C: The Contractor shall hydroseed and place mulch for the Former Warehouse Building #2 cap and backfilled Excavation Areas 2 and 3, as shown on the Drawings and described in the Specifications, as well disturbed areas outside of the capping floodplain restoration areas. The Contractor shall be responsible for maintenance until the vegetative cover is fully established and provisional acceptance is provided by the Owner and Engineer. Any necessary hydroseeding and plantings for the floodplain restoration work will be covered under Streamworks PLLC's Contract. Payment for this Pay Item will be on a lump sum basis.

ITEM 12: TRANSPORTATION AND DISPOSAL OF WASTE ITEMS AND DEBRIS

This item requires Contractor to furnish all labor, equipment, and materials necessary to transport and dispose of materials generated during the Work at properly-permitted facilities and in compliance with local, state, and federal laws and regulations. These proposed facilities will be approved by Owner and/or Sanborn Head prior to transport and disposal. The following tasks are considered incidental to these items:

- Coordination of truck traffic around and at the site. Special care shall be taken to limit the impact of truck traffic on other operations at the site and at adjacent properties;
- Loading trucks, including best management practices (BMPs) for dust and debris management;

- Manifesting and other paperwork required for the trucks transporting waste to the approved disposal facility; and
- Cleaning trucks prior to their departure from the work area, with decontamination liquids managed in accordance with the Specifications.

Payment for this item will include all necessary surcharges, local, state, and federal taxes and other fees. Payment will either be made on a per ton basis based on certified weight slip documentation provided by the disposal facility and submitted by Contractor, or on a lump sum basis, as specified on the individual bid items in the Bid Schedule.

This Work is organized into five (5) pay items:

Item 12A: is for management, transport, and disposal of impacted soil removed from Excavation Areas 1 through 4. Payment will be on a cost per ton of material disposed of as determined by certified weight slip documentation from the receiving facility.

Item 12B is for management, transport, and disposal of the soil/gravel from the gravel access road and decontamination pad. It is anticipated that the used gravel from the decontamination pad will be sent off-site with the final shipment of non-hazardous waste. Payment will be on a lump sum basis.

Item 12C: is for management, transport, and disposal of erosion control measures and accumulated sediment. If the tested sediment is found to be impacted by lead, antimony, or PAHs, the erosion control materials and sediment will be handled accordingly as impacted, presumably non-hazardous waste, and disposed of off-site at an Engineer-approved receiving. Payment will be on a lump sum basis.

Item 12D: is for management, transport, and disposal of stumps, roots, vegetation, and any invasive species (e.g., Japanese Knotweed) generated during clearing and grubbing in Pay Item 4. Payment will be on a cost per ton of material disposed of as determined by certified weight slip documentation from the receiving facility.

Item 12E: is for management, transport, and disposal of miscellaneous trash generated as part of the remediation. Payment will be on a lump sum basis.

ITEM 13: SOURCE AND TRANSPORTATION OF ROCK CAP MATERIAL (CONTINGENCY)

If enough 9-inch minimum rock is not encountered as part of restoration activities in Excavation Area 1, or if rock encountered is not deemed suitable for capping by the Engineer, the Contractor will obtain the necessary rock for capping from a facility approved by Sanborn Head. We estimate approximately 20 CY of 9-inch minimum rock is needed for capping the northern portion of the Northeast Former Dye House Cap Area. This Contingency Pay Item will be on a CY basis and include loading and transportation costs.

p:\4000s\4088.012\source files\bid documents\procurement documents\202511-bid schedule.docx

Available Information

AVAILABLE INFORMATION

**Brownfields Cleanup
Former Woods Woolen Mill
23-25 West Mill Street, Hillsborough, New Hampshire
NHDES Site #: 199909015**

The Former Woods Woolen Mill located at 23-25 West Mill Street in Hillsborough, New Hampshire (the site), has been the subject of several environmental investigations. A list of significant site-related environmental reports is provided below and can be reviewed online at the NHDES OneStop database (<https://www4.des.state.nh.us/DESOnestop/BasicSearch.aspx>) under NHDES Site No. 199909015.

Prior to submitting a Bid, Contractor shall review and understand the available information, and develop appropriate means and methods for executing the Work of these Contract Documents accordingly. Additionally, Contractor shall ensure that the site foreman and laborers fully review and understand the available information prior to implementing remedial actions at the site. Project delays and defective work (i.e., does not adhere to the Drawings and Technical Specifications and is deemed inadequate upon Sanborn Head inspection) resulting from Contractor, including the site foreman, not fully reviewing and understanding the available information will be at the Contractor's expense. Signatory indicates that he/she is authorized to endorse the above conditions for Contractor:

Firm: _____

Name (Print): _____

Title: _____

Signature: _____

Date: _____

The information is made available to Contractor for information and factual data only, and is not a warranty of subsurface conditions. Contractor should base their means and methods for executing the Work not only on the available information, but also on local experience and knowledge. Contractor is required to evaluate site conditions that may affect the performance of the Work.

The list below is not intended to be comprehensive; refer to above for additional site-related documentation.

“Limited Phase II Soil Sampling Summary Letter, Map 25 Lot 27 NHDRED Parcel, Former Woods Woolen Mill Site, Hillsborough, New Hampshire”, prepared by Sanborn, Head & Associates, Inc., dated August 8, 2018.

“Supplemental Phase II Environmental Site Assessment Former Woods Woolen Mill Site, Hillsborough, New Hampshire”, prepared by Sanborn, Head & Associates, Inc., dated March 30, 2021.

“Removal Program After Action Report for the Woods Woolen Mill Site, Hillsborough, Hillsborough County, New Hampshire”, prepared for the U.S. Environmental Protection Agency by Weston Solutions, Inc., dated November 2022.

“Analysis of Brownfields Cleanup Alternatives Update/Remedial Action Plan, Former Woods Woolen Mill Site, 23-25 West Mill Street, Hillsborough, NH”, prepared by Sanborn, Head & Associates, Inc., dated October 2025.

“Construction Design Drawings Former Woods Woolen Mill Site, 23-25 West Mill Street, Hillsborough, NH, NHDES Site No: 19990915”, prepared by Sanborn, Head & Associates, Inc. and dated December 2025 (attached).

“Technical Specifications Former Woods Woolen Mill Site, 23-25 West Mill Street, Hillsborough, NH, NHDES Site No: 19990915”, prepared by Sanborn, Head & Associates, Inc. and Streamworks PLLC, dated November 2025 (attached).

\\conserv1\shdata\4000s\4088.012\Source Files\Bid Documents\Procurement Documents\202511-Available Information.docx

CONTRACTING

Notice of Award

NOTICE OF AWARD

**Brownfields Cleanup
Former Woods Woolen Mill
23-25 West Mill Street, Hillsborough, New Hampshire
NHDES Site #: 199909015**

Dated _____ 2025

TO: _____
(BIDDER)

ADDRESS: _____

ENGINEER'S PROJECT NO: _____

PROJECT: _____

CONTRACT FOR: _____

(Insert name of contract as it appears in the Bid Documents)

You are notified that your Bid _____ for the above Contract has been considered. You are the apparent successful bidder and have been awarded a contract for:

(Indicate total Work, alternates or sections of Work awarded)

The Contract Price of your contract is _____

An electronic copy of each of the proposed Contract Documents accompany this Notice of Award.

You must comply with the following conditions precedent within seven (7) days of receiving this Notice of Award.

1. You must deliver to Engineer all of the fully executed counterparts of the Agreement including all the Contract Documents. This includes the sets of Drawings. Each of the Contract Documents must bear your signature on (the cover) page. Fully executed Contract Documents are to be provided electronically to the Engineer.
2. You must deliver with the executed Agreement the Contract Security (Bonds) as specified in the Information for Bidders and General or Supplementary Conditions.
3. Contractor must deliver to Engineer the attached certification signed by a company officer indicating that Contractor has read and understands the documents specified under Available Information.

Failure to comply with these conditions within the time specified will entitle Engineer to consider your bid abandoned, to annul this Notice of Award and to declare your Bid Security forfeited.

(Engineer)

By

(AUTHORIZED SIGNATURE)

(TITLE)

ACCEPTANCE OF NOTICE

Receipt of the above NOTICE OF AWARD is hereby acknowledged

By _____

The _____ day of _____, 20 _____

By _____

Title _____

Copy to Owner

(Use Certified Mail, Return Receipt Requested)

Construction Agreement

CONSTRUCTION AGREEMENT

**Brownfields Cleanup
Former Woods Woolen Mill
23-25 West Mill Street, Hillsborough, New Hampshire
NHDES Site #: 199909015**

THIS AGREEMENT made this ____ day of _____ in the year 2026 by and between Sanborn, Head & Associates, Inc. (hereinafter called “Engineer” or “Sanborn Head”) and _____, doing business as an _____ (individual, partnership, or corporation) (hereinafter called “Contractor”).

Sanborn Head and Contractor, in consideration of the mutual covenants hereinafter set forth, agree as follows:

ARTICLE 1. WORK

Contractor shall commence and complete all Work as specified or indicated in Sanborn Head’s Contract Documents as the Base Bid. Contractor will need to prepare a separate bid for Streamworks PLLC’s Contract which includes floodplain restoration for a portion of the site. Sanborn Head’s Contract is subject to Sanborn Head’s Construction Design Drawings (Sheet Numbers 1 through 5), and the Technical Specifications, unless otherwise noted as being the responsibility of the “Hydraulic Engineer”. The Work affiliated with Sanborn Head’s Contract is generally described as Brownfields Cleanup at the Former Woods Woolen Mill site located at 23-25 West Mill Street in Hillsborough, New Hampshire, and includes but is not limited to:

- Mobilizing and demobilizing materials, equipment, and personnel required to complete the Work;
- Excavating select areas where lead, polycyclic aromatic hydrocarbon (PAH), and antimony-impacted soils that exceed the NHDES Soil Remediation Standards (SRS) remain on-Site;
- Transporting and disposing of the following waste streams at appropriately permitted, Sanborn Head-approved, off-site disposal facilities: wood and vegetation from grubbing activities, impacted soils from the remedial excavation areas, and accumulated sediment and silt logs;
- Construction of a soil and/or rock cap to cover areas where lead, arsenic, chromium, and/or PAH-impacted soils remain in-place within the Warehouse Building #2 area and within the former Dye House area;
- Caps will be constructed using soil and/or rock from Sanborn Head-approved on-site areas or with imported, off-site, clean fill materials if on-site material is not deemed suitable for reuse; and
- Decontaminating equipment and vehicles used for this project prior to leaving work areas or the site.

Additional cleanup work tasks may be added to the Contract with the written approval of Sanborn Head and Contractor. Additional cleanup work tasks associated with the floodplain restoration portion of the Work will be covered by Streamworks' Contract.

ARTICLE 2. CONTRACT TIMES

2.1 Contractor will commence the Work within seven (7) calendar days after the date specified in the Notice to Proceed unless the period for completion is otherwise extended by the Contract Documents. Substantial completion time for the project will be within 60 calendar days from the date of mobilization, which shall be in Spring 2026.

Substantial Completion shall be defined as when the Work as described in the Contract Documents has been completed to the extent that Owner may occupy and/or make use of the Work performed for the purposes for which it was intended. Upon substantial completion, there may be minor items, such as landscaping, etc., yet to be completed or items of Work to be corrected. Final approval shall be defined as when the project is complete and ready for final payment.

2.2 Liquidated Damages. Sanborn Head and Contractor recognize that time is of the essence for this Agreement and that Sanborn Head will suffer financial loss if the Work is not completed within the times specified in Paragraph 2.1 above, plus any extensions thereof allowed in accordance with the General Conditions. They also recognize the delays, expense and difficulties involved in proving the actual loss suffered by Sanborn Head if the Work is not completed on time. Accordingly, instead of requiring any such proof, Sanborn Head and Contractor agree that as liquidated damages for delay (but not as a penalty) Contractor shall pay Sanborn Head: one thousand five hundred dollars (\$1,500.00) for each day, in whole or in part, that expires after the time specified in Paragraph 2.1 for Substantial Completion of Work.

ARTICLE 2. CONTRACT PRICE

3.1 Sanborn Head shall pay Contractor for completion of the Work in accordance with the Contract Documents for the Total Contract Value of (sum of Base Bid and Bonds)

_____ dollars
(words)
(\$ _____)
(figures)

3.2 The Contract Price is reflected in Contractor's Bid Schedule incorporated as Exhibit A to this Agreement. Estimated quantities provided in the Bid Schedule are not guaranteed, and determinations of actual quantities and classification are to be made during construction.

3.3 The Contract Price may be adjusted only by Change Order as provided by the Contract Documents.

3.4 The term "Contract Documents" means and includes the following:

- 3.4.1 Invitation to Bid
- 3.4.2 Instructions to Bidders
- 3.4.3 Bid Form
- 3.4.4 Bidders Information Form
- 3.4.5 Bid Schedule
- 3.4.6 Available Information
- 3.4.7 Notice of Award
- 3.4.8 Construction Agreement
- 3.4.9 Payment Bond
- 3.4.10 Performance Bond
- 3.4.11 Notice To Proceed
- 3.4.12 Contractor's Affidavit
- 3.4.13 Contractor's Release
- 3.4.14 Application For Payment
- 3.4.15 Change Order(s)
- 3.4.16 Certificate of Substantial Completion
- 3.4.17 Certificate of Authority
- 3.4.18 General Conditions
- 3.4.19 Supplemental Conditions
- 3.4.20 Drawings and Specifications Prepared by:

Sanborn, Head & Associates, Inc., titled "*Construction Design Drawings and Technical Specifications, Former Woods Woolen Mill Site, New Hampshire, NHDES Site No: 19990915*" and dated December 2025 (attached).

3.4.21 Addenda

No. _____, dated _____, 20__

No. _____, dated _____, 20__

No. _____, dated _____, 20__

No. _____, dated _____, 20__

No. _____, dated _____, 20__

ARTICLE 4. PAYMENT PROCEDURES

Contractor shall submit Applications for Payment in accordance with the General Conditions. Applications for Payment will be reviewed by Sanborn Head as provided in the General Conditions.

- 4.1 *Progress Payments.* Sanborn Head shall make progress payments on account of the Contract Price on the basis of Contractor's Applications for Payment as recommended by Sanborn Head, during construction. All such payments will be based upon the approved measured or estimated quantity of each contract item and the corresponding price as reflected in the Bid Schedule (and in the case of Unit Price Work based on the number of units completed) or, in the event there is no item in the Bid Schedule, as provided in the General Requirements.
- 4.2 *Retainage.* Sanborn Head shall pay during the performance of the Work a percentage of approved portions of each Application for Payment, and withhold a percentage of retainage until final completion as described in the General Conditions. Retainage, less an amount adequate to cover: (a) the costs of all defective, rejected or incomplete Work, (b) all damages, losses or expenses incurred by Sanborn Head on account of defective, rejected or incomplete Work or Contractor's performance of the Work, and (c) all claims or demands made or liens filed by any person or entity against Sanborn Head, the Work or the Project site on account of the Work or failure to pay Subcontractors, laborers or Suppliers, shall be paid upon certification of Contractor's completion of the Work as provided by the Contract Documents. The amount of retainage shall in no way limit Contractor's liability under this Agreement. Final payment will not be made until Sanborn Head receives all waste disposal documents (e.g., manifests, waste shipment records).

ARTICLE 5. CONTRACTOR'S REPRESENTATIONS

To induce Sanborn Head to enter this Agreement, Contractor makes the following representations:

- 5.1 Contractor has examined and carefully studied the Contract Documents (including the Addenda) and the other related data identified in the Bid Documents.
- 5.2 Contractor has become familiar with and is satisfied as to the general, local and site conditions that may affect cost, progress, performance or furnishing of the Work.
- 5.3 Contractor is familiar with and is satisfied as to all Federal, State and local laws and regulations that may affect cost, progress, performance and furnishing of the Work.
- 5.4 Contractor has studied carefully all reports of explorations and tests of subsurface and building conditions which are identified in the Contract Documents or given to

Contractor and has reviewed and checked all information and data shown or indicated on the Contract Documents with respect to existing underground facilities at or contiguous to the site and assumes responsibility for the accurate location of said underground facilities. No additional examinations, investigations, explorations, tests, reports, studies, or similar information or data will be required by Contractor in order to perform and furnish the Work at the Contract Price, within the Contract Time and in accordance with the other terms and conditions of the Contract Documents.

- 5.5 Contractor is aware of the general nature of work to be performed by Sanborn Head and others at the site that relates to the Work as indicated in the Contract Documents and agrees that the areas for parking and storage and lay down of materials, and access to the site are acceptable to Contractor, and that Sanborn Head will not be required to alter or interrupt any operations going on at the project site.
- 5.6 Contractor has correlated the information known to Contractor, information and observations obtained from visits to the site, reports and drawings identified in the Contract Documents and all additional examinations, investigations, explorations, tests, studies and data with the Contract Documents.
- 5.7 Contractor has given Sanborn Head written notice of all conflicts, errors, ambiguities or discrepancies that Contractor has discovered in the Contract Documents and the written resolution thereof by Sanborn Head is acceptable to Contractor, and the Contract Documents are generally sufficient to indicate and convey understanding of all terms and conditions for performance and furnishing of the Work.
- 5.8 Contractor is experienced and qualified to perform the services described herein, and is properly staffed, organized and financed to perform such services. Contractor shall act as an independent Contractor and not as an agent of Sanborn Head in performing its services, maintaining control over its employees and managing all subcontractors and suppliers.

This Agreement shall be binding upon all parties hereto and their respective heirs, executors, administrators, successors, and assigns.

IN WITNESS WHEREOF, the parties hereto have executed, or caused to be executed by their duly authorized officials, this Agreement.

ENGINEER:

CONTRACTOR:

Sanborn, Head & Associates, Inc.

By: _____

[CORPORATE SEAL]

By: _____

[CORPORATE SEAL]

Attest _____

Attest _____

ENGINEER:

CONTRACTOR:

Address for giving notices:

Address for giving notices:

Attn: Heidi Caprood
Sanborn, Head & Associates, Inc. _____

6 Bedford Farms Drive, Suite 201 _____

Bedford, NH 03110 _____

(If Engineer is public body, attach evidence of authority to sign and resolution or other documents authorizing execution of Agreement.)

Agent for Service of Process: _____

(If Contractor is a corporation, attach evidence of authority to sign.)

P:\4000s\4088.012\Source Files\Bid Documents\Contracting Documents\202507-Constructionagmt.Docx

Payment Bond

PAYMENT BOND

**Brownfields Cleanup
Former Woods Woolen Mill
23-25 West Mill Street, Hillsborough, New Hampshire
NHDES Site #: 199909015**

KNOW ALL MEN BY THESE PRESENTS: that

(Name of Contractor)

(Address of Contractor)

a _____, hereinafter called Principal,
(Corporation, Partnership or Individual)

and _____
(Name of Surety)

(Address of Surety)

hereinafter called Surety, are held and firmly bound unto

(Name of Engineer)

(Address of Engineer)

hereinafter called **Engineer** and unto all persons, firms, and corporations who or which may furnish labor, or who furnish materials to perform as described under the contract and to their successors

and assigns, in the total aggregate penal sum
of _____ Dollars,
(\$ _____) in lawful money of the United States, for the payment of which sum well

truly to be made, we bind ourselves, our heirs, executors, administrators, successors, and assigns, jointly and severally, firmly by these presents.

THE CONDITION OF THIS OBLIGATION is such that whereas, the Principal entered into a

certain contract with **Engineer**, dated the _____ day of _____

20 _____, a copy of which is hereto attached and made a part hereof for the construction of:

Brownfields Cleanup: Former Woods Woolen Mill, Hillsborough, New Hampshire

NOW, THEREFORE, if the Principal shall promptly make payment to all persons, firms, and corporations furnishing materials for or performing labor in the prosecution of the Work provided for in such Contract, and any authorized extension or modification thereof, including all amounts due for materials, lubricants, oil, gasoline, coal and coke, repairs on machinery, equipment and tools, consumed or used in connection with the construction of such Work, and for all labor cost incurred in such Work including that be a subcontractor, and to any mechanic or materialman lienholder whether it acquires its lien by operation of State or Federal Law; then this obligation shall be void; otherwise to remain in full force and effect.

PROVIDED, that beneficiaries or claimants hereunder shall be limited to the subcontractors, and persons, firms, and corporations having a direct contract with the Principal or its SUBCONTRACTORS.

PROVIDED FURTHER, that the said Surety for value received hereby stipulates and agrees that no change, extension of time, alteration or addition to the terms of the contract or to the Work to be performed thereunder or the Specifications accompanying the same shall in any way affect its obligation on this Bond, and it does hereby waive notice of any such change, extension of time, alteration or addition to the terms of the contract or to the Work or to the Specifications.

PROVIDED, FURTHER that no suit or action shall be commenced hereunder by any claimant: (a) Unless claimant, other than one having a direct contract with the Principal shall have given written notice to any two of the following: The Principal, Engineer, or the Surety above named within ninety (90) days after such claimant did or performed the last of the work or labor, or furnished the last of the materials for which said claim is made, stating with substantial accuracy the amount claimed and the name of the party to whom the materials were furnished, or for whom the work or labor was done or performed. Such notice shall be served by mailing the same by registered mail or certified mail, postage prepaid, in an envelope addressed to the Principal, Engineer, or Surety, at any place where an office is regularly maintained for the transaction business, or served in any manner in which legal process may be served in the state in which the aforesaid project is located, save that such service need not be made by a public officer. (b) After the expiration of one (1) year following the date on which Principal ceased work on said Contract, it being understood, however, that if any limitation embodied in the Bond is prohibited by any law controlling the construction hereof, such limitation shall be deemed to be amended so as to be equal to the minimum period of limitation permitted by such law.

PROVIDED, FURTHER, that it is expressly agreed that this Bond shall be deemed amended automatically and immediately, without formal and separate amendments hereto, upon amendment to the Contract not increasing the contract price more than 25 percent, so as to bind the Principal and the Surety to the full and faithful performance of the Contract as so amended. The term "Amendment", wherever used in this Bond and whether referring to this Bond, the contract or the loan Documents shall include any alteration, addition, extension or modification of any character whatsoever.

PROVIDED FURTHER, that no final settlement between Engineer and Contractor shall abridge the right of any beneficiary hereunder, whose claim may be unsatisfied.

IN WITNESS WHEREOF, this instrument is executed in _____ counterparts, each one of
(number)
which shall be deemed an original,
this _____ day of _____, 20 ____ .

ATTEST:

By: _____
(Principal) Secretary

(SEAL) **BY**

Principal

(Address)

By: _____
Witness as to Principal

(Address)

(Surety)

ATTEST:

BY

By _____
Witness as to Surety

(Address)

Attorney - in - Fact

(Address)

NOTE: Date of **Bond** must not be prior to date of Contract.
If **Contractor** is partnership, all partners should execute Bond.

IMPORTANT: Surety companies executing **Bonds** must appear on the Treasury Department's most current list (Circular 570 as amended) and be authorized to transact business in the State of New Hampshire.

Performance Bond

PERFORMANCE BOND

**Brownfields Cleanup
Former Woods Woolen Mill
23-25 West Mill Street, Hillsborough, New Hampshire
NHDES Site #: 199909015**

KNOW ALL MEN BY THESE PRESENTS: that

(Name of Contractor)

(Address of Contractor)

a _____, hereinafter called Principal,

(Corporation, Partnership or Individual)

and

(Name of Surety)

(Address of Surety)

hereinafter called Surety, are held and firmly bound unto

(Name of Engineer)

(Address of Engineer)

hereinafter called Engineer, in the total aggregate penal sum of _____

Dollars, \$ (_____)

in lawful money of the United States, for the payment of which sum well and truly to be made, we bind ourselves, our heirs, executors, administrators successors, and assigns, jointly and severally, firmly by these presents.

THE CONDITION OF THIS OBLIGATION is such that whereas, the Principal entered into a

certain contract with Engineer, dated the _____ day of _____ 20 ____, a

copy of which is hereto attached and made a part hereof for the:

Brownfields Cleanup:

Former Woods Woolen Mill, Hillsborough, New Hampshire

NOW, THEREFORE, if the Principal shall well, truly and faithfully perform its duties, all the undertakings, covenants, terms, conditions, and agreements of said Contract during the original term thereof, and any extension thereof which may be granted by Engineer, with or without notice to the Surety and during the one year guaranty period, and if the Principal shall satisfy all claims and demands incurred under such Contract, and shall fully indemnify and save harmless the Engineer from all costs and damages which it may suffer by reason of failure to do so, and shall reimburse and repay the Engineer all outlay and expense which Engineer may incur in making good any default, then this obligation shall be void: otherwise to remain in full force and effect.

PROVIDED, FURTHER, that the said Surety, for value received hereby stipulates and agrees that no change, extension of time, alteration or addition to the terms of the Contract or to Work to be performed thereunder or the Specifications accompanying same shall in any way affect its obligation on this Bond, and it does hereby waive notice of any such change, extension of time alteration or addition to the terms of the Contract or to the Work or to the Specifications.

PROVIDED, FURTHER, that it is expressly agreed that this Bond shall be deemed amended automatically and immediately, without formal and separate amendments hereto, upon amendment to the Contract not increasing the Contract Price more than 25 percent, so as to bind the Principal and the Surety to the full and faithful performance of the Contract as so amended. The term "Amendment", wherever used in this Bond and whether referring to this Bond, the Contract or the loan Documents shall include any alteration, addition, extension or modification of any character whatsoever.

PROVIDED, FURTHER, that no final settlement between Engineer and Contractor shall abridge the right of any beneficiary hereunder, whose claim may be unsatisfied.

IN WITNESS WHEREOF, this instrument is executed in _____ counterparts, each one of which shall be deemed an original, this _____ day of _____, 20 ____.

ATTEST:

By: _____
(Principal) Secretary

(SEAL) BY

Principal

(Address)

By: _____
Witness as to Principal

(Address)

(Surety)

ATTEST:

BY

By _____
Witness as to Surety

Attorney - in - Fact

(Address)

(Address)

NOTE: Date of Bond must not be prior to date of Contract.

If Contractor is Partnership, all partners should execute Bond

IMPORTANT: Surety companies executing Bonds must appear on the Treasury Department's most current list (Circular 570 as amended) and be authorized to transact business in the State of New Hampshire.

Notice to Proceed

NOTICE TO PROCEED

**Brownfields Cleanup
Former Woods Woolen Mill
23-25 West Mill Street, Hillsborough, New Hampshire
NHDES Site #: 199909015**

Dated _____, 20 ____

TO: _____
(Insert Name of Contractor as it appears in the Bid Documents)

ADDRESS: _____

ENGINEER'S PROJECT NO. _____

PROJECT: _____

OWNER'S CONTRACT NO. _____

CONTRACT FOR: _____

You are notified that the Contract Time under the above contract will commence to run on _____, 20 ____ . By that date, you are to start performing your obligations under the Contract Documents. In accordance with Article 2 of the Agreement, the dates of Substantial Completion and Final Completion are _____, 20 ____ and _____, 20 ____ , respectively.

Before you may start any Work at the site, paragraph 22 of the General Conditions provides that you must deliver to Engineer (with copies to Owner) certificates of insurance which is required to be purchased and maintained in accordance with the Contract Documents.

Also before you may start any Work at the site, you must:

(add other requirements)

Copy to Engineer

(Use Certified Mail, Return Receipt Requested)

By

(Engineer)

(Authorized Representative)

(Title)

ACCEPTANCE OF NOTICE

Receipt of the above Notice to Proceed is hereby acknowledged by:

(Contractor)

this the _____, 20 ____

Employer Identification

Number: _____

By: _____

(Title)

P:\4000s\4088.012\Source Files\Bid Documents\Contracting Documents\202511-Notice to Proceed.docx

Contractor's Affidavit

CONTRACTOR'S AFFIDAVIT

**Brownfields Cleanup
Former Woods Woolen Mill
23-25 West Mill Street, Hillsborough, New Hampshire
NHDES Site #: 199909015**

STATE OF: _____

COUNTY OF: _____

Before me, the undersigned, a _____
(Notary Public, Justice of Peace, Alderman)

in and for said County and State personally appeared, _____
(Individual, Partner or duly

_____ who being duly sworn according to law
authorized representative of corporate contractor)

deposes and says that the cost of all the Work, and outstanding claims and indebtedness of whatever
nature arising out of the performance of the contract between _____

and _____ of _____
(Contractor)

dated _____ for the construction of the _____

and necessary appurtenant installations have been paid in full.

(Individual, Partner, or duly authorized representative of corporate contractor)

(Title)

Sworn to and subscribed before me

this _____ day of _____, 20 ____

Notary Public

Contractor's Release

CONTRACTOR'S RELEASE

**Brownfields Cleanup
Former Woods Woolen Mill
23-25 West Mill Street, Hillsborough, New Hampshire
NHDES Site #: 199909015**

KNOW ALL MEN BY THESE PRESENTS that _____

(Contractor)

of _____, County of _____
and State of _____ do _____ hereby acknowledge that

(Contractor)

has _____ this day had, and received of and from _____

(Engineer)

the sum of One Dollar and other valuable considerations in full and complete satisfaction and
payment of all sums of money owed, payable and belonging to

(Contractor)

by any means whatsoever, for on account of a Contract Agreement between

(Engineer)

and _____
(Contractor)

dated _____ for _____
(Project)

NOW, THEREFORE, the said _____
(Contractor)

(for myself, my heirs, executors and administrators) (for itself, its successors and assigns)

do/does, by these presents remise, release, quit-claim and forever discharge _____
(Owner)

_____, of and from all claims and demands, arising from or in
connection with the said contract dated _____, and of and from all, and all manner of

action and actions, cause and causes of action and actions, suits, debts, dues, duties, sum and sums of money, accounts, reckonings, bonds, bills, specialties, covenants, contracts, agreements, promises, variances, damages, judgments, extents, executions, claims and demand, whatsoever in law or _____

(Engineer)

its successors and assigns, which (I, my heirs, executors, or administrators) (it, its successors and assigns) ever had, now have or which (I, my heirs, executors, or administrators) (it, its successors and assigns) hereafter can, shall or may have, for, upon or by reason of any matter, cause, or thing whatsoever; from the beginning of recorded time to the date of these presents.

IN WITNESS WHEREOF, _____

(Contractor)

has caused these presents to be duly executed this _____ day of _____, 20 _____

Signed, Sealed and Delivered in the presence of:

(Individual - Contractor) (seal)

(Partnership - Contractor) (seal)

(seal) By _____
(Partner)

Attested:

(Corporation)

(Secretary) By _____
(President or Vice President)

(Corp. Seal)

Application for Payment

Contractor's Application for Payment

Owner: <u>NHDES</u>	Owner's Project No.: _____
Engineer: <u>Sanborn, Head & Associates, Inc.</u>	Engineer's Project No.: <u>4088.012</u>
Contractor: _____	Contractor's Project No.: _____
Project: <u>Former Woods Woolen Mill</u>	
Contract: <u>Brownfields Cleanup</u>	
Application No.: _____	Application Date: _____
Application Period: From _____ to _____	

1. Original Contract Price	\$	-
2. Net change by Change Orders	\$	-
3. Current Contract Price (Line 1 + Line 2)	\$	-
4. Total Work completed and materials stored to date (Sum of Column G Lump Sum Total and Column J Unit Price Total)	\$	-
5. Retainage		
a. _____ X \$ - Work Completed =	\$	-
b. _____ X \$ - Stored Materials =	\$	-
c. Total Retainage (Line 5.a + Line 5.b)	\$	-
6. Amount eligible to date (Line 4 - Line 5.c)	\$	-
7. Less previous payments (Line 6 from prior application)		
8. Amount due this application	\$	-
9. Balance to finish, including retainage (Line 3 - Line 4 + Line 5.c)	\$	-

Contractor's Certification

The undersigned Contractor certifies, to the best of its knowledge, the following:

(1) All previous progress payments received from Owner on account of Work done under the Contract have been applied on account to discharge Contractor's legitimate obligations incurred in connection with the Work covered by prior Applications for Payment;

(2) Title to all Work, materials and equipment incorporated in said Work, or otherwise listed in or covered by this Application for Payment, will pass to Owner at time of payment free and clear of all liens, security interests, and encumbrances (except such as are covered by a bond acceptable to Owner indemnifying Owner against any such liens, security interest, or encumbrances);

(3) All the Work covered by this Application for Payment is in accordance with the Contract Documents and is not defective; and,

(4) An itemized back-up table (by bid item) is attached to each invoice.

Contractor: _____

Signature: _____ **Date:** _____

Recommended by Engineer	Approved by Owner
By: _____	By: _____
Title: _____	Title: _____
Date: _____	Date: _____
Approved by Funding Agency	
By: _____	By: _____
Title: _____	Title: _____
Date: _____	Date: _____

Progress Estimate - Lump Sum Work

Contractor's Application for Payment

Owner:	NHDES	Owner's Project No.:	
Engineer:	Sanborn, Head & Associates, Inc.	Engineer's Project No.:	4088.012
Contractor:		Contractor's Project No.:	
Project:	Former Woods Woolen Mill		
Contract:	Brownfields Cleanup		

Application No.: _____ **Application Period:** From _____ to _____ **Application Date:** _____

A	B	C	D	E	F	G	H	I
Item No.	Description	Scheduled Value (\$)	Work Completed		Materials Currently Stored (not in D or E) (\$)	Work Completed and Materials Stored to Date (D + E + F) (\$)	% of Scheduled Value (G / C) (%)	Balance to Finish (C - G) (\$)
			(D + E) From Previous Application (\$)	This Period (\$)				
Original Contract								
						-		-
						-		-
						-		-
						-		-
						-		-
						-		-
						-		-
						-		-
						-		-
						-		-
						-		-
						-		-
						-		-
						-		-
						-		-
						-		-
						-		-
Original Contract Totals		\$ -	\$ -	\$ -	\$ -	\$ -		\$ -

Progress Estimate - Lump Sum Work

Contractor's Application for Payment

Owner:	NHDES	Owner's Project No.:	
Engineer:	Sanborn, Head & Associates, Inc.	Engineer's Project No.:	4088.012
Contractor:		Contractor's Project No.:	
Project:	Former Woods Woolen Mill		
Contract:	Brownfields Cleanup		

Application No.:		Application Period:	From	to	Application Date:	
-------------------------	--	----------------------------	-------------	-----------	--------------------------	--

A	B	C	D	E	F	G	H	I
Item No.	Description	Scheduled Value (\$)	Work Completed		Materials Currently Stored (not in D or E) (\$)	Work Completed and Materials Stored to Date (D + E + F) (\$)	% of Scheduled Value (G / C) (%)	Balance to Finish (C - G) (\$)
			(D + E) From Previous Application (\$)	This Period (\$)				
Change Orders								
						-		-
						-		-
						-		-
						-		-
						-		-
						-		-
						-		-
						-		-
						-		-
						-		-
						-		-
						-		-
						-		-
						-		-
						-		-
						-		-
						-		-
						-		-
						-		-
						-		-
						-		-
	Change Order Totals	\$ -	\$ -	\$ -	\$ -	\$ -		\$ -
Original Contract and Change Orders								
	Project Totals	\$ -	\$ -	\$ -	\$ -	\$ -		\$ -

Progress Estimate - Unit Price Work

Contractor's Application for Payment

Owner:	NHDES	Owner's Project No.:	
Engineer:	Sanborn, Head & Associates, Inc.	Engineer's Project No.:	4088.012
Contractor:		Contractor's Project No.:	
Project:	Former Woods Woolen Mill		
Contract:	Brownfields Cleanup		

Application No.: _____ Application Period: From _____ to _____ Application Date: _____

A	B	C	D	E	F	G	H	I	J	K	L
Bid Item No.	Description	Contract Information				Work Completed		Materials Currently Stored (not in G) (\$)	Work Completed and Materials Stored to Date (H + I) (\$)	% of Value of Item (J / F) (%)	Balance to Finish (F - J) (\$)
		Item Quantity	Units	Unit Price (\$)	Value of Bid Item (C X E) (\$)	Estimated Quantity Incorporated in the Work	Value of Work Completed to Date (E X G) (\$)				
Original Contract											
					-		-		-		-
					-		-		-		-
					-		-		-		-
					-		-		-		-
					-		-		-		-
					-		-		-		-
					-		-		-		-
					-		-		-		-
					-		-		-		-
					-		-		-		-
					-		-		-		-
					-		-		-		-
					-		-		-		-
					-		-		-		-
					-		-		-		-
					-		-		-		-
					-		-		-		-
					-		-		-		-
					-		-		-		-
					-		-		-		-
					-		-		-		-
					-		-		-		-
					-		-		-		-
					-		-		-		-
					-		-		-		-
					-		-		-		-
Original Contract Totals					\$	-		\$	-	\$	-

Progress Estimate - Unit Price Work

Contractor's Application for Payment

Owner:	NHDES	Owner's Project No.:	
Engineer:	Sanborn, Head & Associates, Inc.	Engineer's Project No.:	4088.012
Contractor:		Contractor's Project No.:	
Project:	Former Woods Woolen Mill		
Contract:	Brownfields Cleanup		

Application No.: _____ Application Period: From _____ to _____ Application Date: _____

A	B	C	D	E	F	G	H	I	J	K	L
Bid Item No.	Description	Item Quantity	Units	Unit Price (\$)	Value of Bid Item (C X E) (\$)	Work Completed		Materials Currently Stored (not in G) (\$)	Work Completed and Materials Stored to Date (H + I) (\$)	% of Value of Item (J / F) (%)	Balance to Finish (F - J) (\$)
						Estimated Quantity Incorporated in the Work	Value of Work Completed to Date (E X G) (\$)				
Change Orders											
					-		-		-		-
					-		-		-		-
					-		-		-		-
					-		-		-		-
					-		-		-		-
					-		-		-		-
					-		-		-		-
					-		-		-		-
					-		-		-		-
					-		-		-		-
					-		-		-		-
					-		-		-		-
					-		-		-		-
					-		-		-		-
					-		-		-		-
					-		-		-		-
					-		-		-		-
					-		-		-		-
					-		-		-		-
Change Order Totals					\$ -		\$ -	\$ -	\$ -		\$ -
Original Contract and Change Orders											
Project Totals					\$ -		\$ -	\$ -	\$ -		\$ -

Stored Materials Summary

Contractor's Application for Payment

Owner:	NHDES	Owner's Project No.:	
Engineer:	Sanborn, Head & Associates, Inc.	Engineer's Project No.:	4088.012
Contractor:		Contractor's Project No.:	
Project:	Former Woods Woolen Mill		
Contract:	Brownfields Cleanup		

Application No.:		Application Period: From			to			Application Date:					
A	B	C	D	E	F	G	H	I	J	K	L	M	
Item No. (Lump Sum Tab) or Bid Item No. (Unit Price Tab)	Supplier Invoice No.	Submittal No. (with Specification Section No.)	Description of Materials or Equipment Stored	Storage Location	Application No. When Materials Placed in Storage	Materials Stored			Incorporated in Work			Materials Remaining in Storage (I-L) (\$)	
						Previous Amount Stored (\$)	Amount Stored this Period (\$)	Amount Stored to Date (G+H) (\$)	Amount Previously Incorporated in the Work (\$)	Amount Incorporated in the Work this Period (\$)	Total Amount Incorporated in the Work (J+K) (\$)		
								-			-	-	
								-			-	-	
								-			-	-	
								-			-	-	
								-			-	-	
								-			-	-	
								-			-	-	
								-			-	-	
								-			-	-	
								-			-	-	
								-			-	-	
								-			-	-	
								-			-	-	
								-			-	-	
								-			-	-	
								-			-	-	
								-			-	-	
								-			-	-	
								-			-	-	
								-			-	-	
								-			-	-	
								-			-	-	
Totals						\$	-	\$	-	\$	-	\$	-

Change Orders

CHANGE ORDER

**Brownfields Cleanup
Former Woods Woolen Mill
23-25 West Mill Street, Hillsborough, New Hampshire
NHDES Site #: 199909015**

No. _____

PROJECT: _____ DATE OF ISSUANCE: _____
 Engineer: _____

 (Address)

CONTRACTOR: _____ ENGINEER's Project No. _____
 CONTRACT FOR: _____

You are directed to make the following changes in the Contract Documents.

Description:

Purpose of Change Order:

Justification:

Attachments: (List documents supporting change)

CHANGE IN CONTRACT PRICE	CHANGE IN CONTRACT TIME
Original Contract Price \$ _____	Original Contract Time _____ (days or date)
Previous Change Orders \$ _____	Net change from previous Change Orders _____ (days)
Contract Price prior to this Change Order \$ _____	Contract Time prior to this Change Order _____ (days or date)
Net Increase (Decrease) of this Change Order \$ _____	Net Increase (decrease) this Change Order _____ (days)
Contract Price with all approved Change Orders \$ _____	Contract Time with all Change Orders _____ (days or date)

This document will become a supplement to the Contract and all provisions will apply hereto. The attached Contractor's Revised Project Schedule reflects increases or decreases in Contract Time as authorized by this Change Order.

Stipulated price and time adjustment includes all costs and time associated with the above-described change. Contractor waives all rights for additional time extension for said change. Contractor and

Engineer agree that the price(s) and time adjustment(s) stated above are equitable and acceptable to both parties.

RECOMMENDED BY:

Engineer

Date

APPROVED BY:

Engineer

Date

Contractor

Date

P:\4000s\4088.012\Source Files\Bid Documents\Contracting Documents\202511 -ChangeOrder.docx

Certificate of Substantial Completion

A tentative list of items to be completed or corrected is attached hereto. This list may not be all-inclusive, and the failure to include an item in it does not alter the responsibility of Contractor to complete all the Work in accordance with Contract Documents. The items in the tentative list shall be completed or corrected by Contractor within _____ calendar days of the above date of Substantial Completion.

The responsibilities between Engineer and Contractor for security, operation, safety, maintenance, heat, utilities, insurance and warranties shall be as follows:

RESPONSIBILITIES:

ENGINEER: _____

CONTRACTOR: _____

The following documents are attached to and made a part of this Certificate:

This certificate does not constitute an acceptance of Work not in accordance with the Contract Documents nor is it a release of Contractor's obligation to complete the Work in accordance with the Contract Documents.

Executed by Engineer on _____, 20 _____

(Engineer)

By: _____

Contractor accepts this Certificate of Substantial Completion on _____, 20 _____

(Contractor)

By: _____

Owner accepts this Certificate of Substantial Completion on _____, 20 _____

(Owner)

By: _____

P:\4000s\4088.012\Source Files\Bid Documents\Contracting Documents\202511-Cert of Substantial Completion.docx

Certificate of Authority

CERTIFICATE OF AUTHORITY

**Brownfields Cleanup
Former Woods Woolen Mill
23-25 West Mill Street, Hillsborough, New Hampshire
NHDES Site #: 199909015**

At a meeting of _____ Board of Directors held on _____ at
(Company Name)
which a quorum was present, it was voted that the following individuals of this company, be
and are hereby authorized to execute contracts and bonds in the name of and on behalf of said
company, and to affix its corporate seal thereto (if applicable), and such execution of any
contract or obligation in this company's name or on its behalf by such individual, under seal of
the company (if applicable), shall be valid and binding upon this company.

Name	Title
_____	_____
_____	_____

I hereby certify that I am the clerk of the above-named company, and that the information above is correct and that the above vote has not been amended or rescinded and remains in full force and effect as of this date.

(Clerk signature) (Date)

A true copy, _____
(Attested by Notary Public)

My commission expires on _____
(Date)

P:\4000s\4088.012\Source Files\Bid Documents\Contracting Documents\202511-Cert of Authority.docx

General Conditions

GENERAL CONDITIONS

**Brownfields Cleanup
Former Woods Woolen Mill
23-25 West Mill Street, Hillsborough, New Hampshire
NHDES Site #: 199909015**

Index

1. Contract and Contract Documents
2. Definitions
3. Additional Instructions and Detail Drawings
4. Materials, Services, and Facilities
5. Contractor's Title to Materials
6. Inspection and Testing
7. "Or Equal" Clause, Substitutions and Contractor Options
8. Surveys and Construction Layout
9. Contractor's Obligations
10. Weather Conditions
11. Protection of Work and Property
12. Inspection
13. Reports, Records, and Data
14. Extra Work and Change Orders
15. Time for Completion and Liquidated Damages
16. Defective Work
17. Claims for Differing Site Conditions
18. Claims for Extra Cost
19. Right of Engineer to Terminate Contract
20. Payments to Contractor
21. Acceptance and Final Payment
22. Insurance
23. Bonds
24. Subcontracting
25. Authority of Owner's Representative
26. Use of Premises, Removal of Debris, Sanitary Conditions
27. Estimated Quantities
28. General Guaranty
29. Errors and Inconsistencies in Contract Documents
30. Notice and Service Thereof
31. Required Provisions Deemed Inserted
32. Health and Safety Responsibilities
33. Compliance by Contractor with Laws and Regulations: Equal Employment Opportunity
34. Pre-Construction Meeting
35. Work Performed at Night, and on Weekends and Holidays
36. Laws, Permits, Rules, and Ordinances
37. Indemnification

GENERAL CONDITIONS

1.0 Contract and Contract Documents

- 1.1 The Invitation to Bid, Information for Bidders, Bids, Payment and Performance Bonds, General Conditions, Agreements, Change Orders, Notice of Award, Notice to Proceed, Sanborn Head's Construction Design Drawings, Sanborn Head's Technical Specifications and Addenda, hereinafter enumerated in the Agreement, shall form part of this Contract and the provisions thereof shall be as binding upon the parties hereto as if they were herein fully set forth. The table of contents, titles, headings, running headlines and marginal notes contained herein and in said documents are solely to facilitate reference to various provisions of the Contract Documents and in no way affect, limit or cast light on the interpretation of the provisions to which they refer.

2.0 Definitions

- 2.1 "Addenda" means written or graphic instruments issued prior to the execution of the Agreement which modify or interpret the Contract Documents, drawings and specifications, by additions, deletions, clarifications or corrections.
- 2.2 "Bid" means the offer or proposal of the Bidder submitted on the prescribed form setting forth the prices for the Work to be performed.
- 2.3 "Bidder" means any person, firm or corporation submitting a Bid for the Work.
- 2.4 "Bonds" means Performance and Payment Bonds and other instruments of security, furnished by Contractor and their surety in accordance with the Contract Documents.
- 2.5 "Change Order" means a written order to Contractor authorizing an addition or "Extra Work", deletion or revision in the Work within the general scope of the Contract Documents or authorizing an adjustment in the Contract Price or Contract Time.
- 2.6 "Contract Documents" means the Contract, including any advertisement for Bids, Information for Bidders, Bid, Agreement, Payment Bond, Performance Bond, Notice of Award, Notice to Proceed, Change Orders, Sanborn Head's Construction Design Drawings, Sanborn Head's Technical Specifications and Addenda.
- 2.7 "Contract Price" means the total monies payable to Contractor under the terms and conditions of the Contract Documents.
- 2.8 "Contract Time" means the number of calendar days stated in the Contract Documents for the completion of the Work.

- 2.9 “Contractor” means the person, firm, or corporation with whom Sanborn Head has executed the Agreement.
- 2.10 “Days” means business days unless specifically stated otherwise.
- 2.11 “Drawings” mean the part of the Contract Documents which show the characteristics, scope, dimensions, and details of the Work to be performed and which have been prepared by Sanborn Head and approved by Owner.
- 2.12 “Engineer” means Sanborn, Head & Associates, Inc., who is also referred to as Sanborn Head throughout the Contract Documents.
- 2.13 “Field Order” means a written order effecting a change in the Work not relating to an adjustment in the Contract Price or an extension of the Contract Time and issued by Owner’s Representative to Contractor during construction.
- 2.14 “Final Completion” means that point at which all Work has been completed and all defective Work has been corrected.
- 2.15 “NHDES” means the New Hampshire Department of Environmental Services who is providing funding and regulatory guidance for the remediation project.
- 2.16 “Notice of Award” means the written notice of the acceptance of the Bid from Sanborn Head to the successful Bidder.
- 2.17 “Notice to Proceed” means the written communication issued by Sanborn Head to Contractor authorizing them to proceed with the Work and establishing the date of commencement of the Work.
- 2.18 “Owner” means the Town of Hillsborough (property Owner).
- 2.19 “Project” means the undertaking to be performed as provided in the Contract Documents.
- 2.20 “Owner’s Representative” means the authorized representative of Owner who is assigned to the Project site or any part thereof and may include Sanborn Head, or others as designated by Owner.
- 2.21 “Shop Drawings” means all drawings, diagrams, illustrations, brochures, schedules, and other data which are prepared by Contractor, a Subcontractor, manufacturer, supplier or distributor, which illustrates how specific portions of the Work shall be fabricated or installed.
- 2.22 “Special Conditions” means revisions or additions to these General Conditions, Supplemental Conditions, or specifications applicable to an individual project.

- 2.23 “Specifications” means a part of the Contract Documents consisting of written descriptions of a technical nature of materials, equipment, construction systems, standards, and workmanship and which have been prepared by Sanborn Head and approved by NHDES.
- 2.24 “Subcontractor” means an individual, firm, or corporation having a direct contract with Contractor or with any other Subcontractor for the performance of a part of the Work at the site.
- 2.25 “Substantial Completion” means that date when the Work as described in the Contract Documents has been completed to the extent that Owner may occupy and/or make use of the Work performed for the purposes for which it was intended.
- 2.26 “Supplemental Conditions” means modifications to these General Conditions.
- 2.27 “Supplier” means any person or organization who supplies materials or equipment for the Work, including that fabricated to a special design, but who does not perform labor at the site.
- 2.28 “Work” means all labor necessary, including all materials and equipment incorporated or to be incorporated, to produce the construction required by Sanborn Head’s Contract Documents.
- 2.29 “Written Notice” means any notice to any party of the Agreement relative to any part of this Agreement in writing and considered delivered and the service thereof completed, when emailed and posted by certified or registered mail to the said party at their last given address or delivered in person to said party or their authorized representative on the Work.

3.0 Additional Instructions and Detail Drawings

- 3.1 Contractor may be furnished additional instructions and detail drawings as necessary to carry out the Work included in the Contract Documents. The additional drawings and instructions thus supplied to Contractor will coordinate with the Contract Documents and will be so prepared that they can be reasonably interpreted as part thereof.

4.0 Materials, Services, and Facilities

- 4.1 Except as otherwise specifically stated in the Contract Documents, Contractor shall provide and pay for all materials, labor, tools, equipment, water, light, power, transportation, superintendence, temporary construction of every nature, and all other services and facilities of every nature whatsoever necessary to execute, complete, and deliver the Work within the specified time.

5.0 Contractor's Title to Materials

- 5.1 No material, supplies, or equipment to be installed or furnished under this Contract shall be purchased subject to any chattel mortgage or under a conditional sale, lease purchase or other agreement by which an interest therein or in any part thereof is retained by the seller or supplier. Contractor shall warrant good title to all materials, supplies, and equipment installed or incorporated in the Work and upon completion of all Work, shall deliver the same together with all improvements and appurtenances constructed or placed thereon by them to Sanborn Head and Owner free from any claims, liens, or charges. Neither Contractor nor any person, firm or corporation furnishing any material or labor for any Work covered by this Contract shall have any right to a lien upon any improvement or appurtenance thereon. Nothing contained in this paragraph, however, shall defeat or impair the right of persons furnishing materials or labor to recover under any bond given by Contractor for their protection or any rights under any law permitting such persons to look to funds due Contractor in the hands of Sanborn Head or Owner. The provisions of this paragraph shall be inserted in all subcontracts and material contracts and notice of its provisions shall be given to all persons furnishing materials for the Work when formal contract is entered into for such materials.

6.0 Inspection and Testing

- 6.1 If the Contract Documents, laws, ordinances, rules, regulations or orders of any public authority having jurisdiction require any Work to specifically be inspected, tested or approved by someone other than Contractor, Contractor will give Sanborn Head timely notice of readiness. Contractor will then furnish Sanborn Head with the required certificates of inspection, testing or approval.
- 6.2 Inspections, tests, or approvals by Sanborn Head or others shall not relieve Contractor from obligations to perform the Work in accordance with the requirements of the Contract Documents.

7.0 "Or Equal" Clause, Substitutions and Contractor Options

- 7.1 Whenever a material, article, or piece of equipment is identified on the plans or in the specifications by reference to manufacturer's or vendor's names, trade names, catalogue numbers, etc., it is intended merely to establish a standard of quality and performance. Any material, article, or equipment of other manufacturers and vendors, which will perform satisfactorily the duties imposed by the general design, shall be considered equally acceptable provided the material, article, or equipment so proposed is, in the opinion of Sanborn Head, of equal quality and function. Sanborn Head shall determine equality based on such information, tests, or other supporting data that may be required of Contractor.

- 7.2 Upon acceptance and approval by Sanborn Head of an equal product, it shall remain the responsibility of Contractor to coordinate installation of the item with all other items to be furnished to assure proper fitting together of all items. Similar responsibility applies to items which are left to Contractor's option. Any additional cost of equal items and any additional cost incidental to the coordination and/or fitting together of such items shall be borne by Contractor at no extra cost to Sanborn Head or NHDES.
- 7.3 If a specified or equal item is not available to meet the construction schedule, Contractor may propose a substitute item of less than equal performance and quality. If this substitute is acceptable to Sanborn Head, any difference in purchase cost or costs incidental to the installation of such item will be negotiated between the parties to the contract.
- 7.4 Neither equal nor substitute items shall be installed without written approval of Sanborn Head.
- 7.5 Contractor shall warrant that if substitutes are approved, no major changes in the function or general design of the Project will result.

8.0 Surveys and Construction Layout

- 8.1 Contractor shall be responsible for hiring a New-Hampshire licensed surveyor to layout proposed construction areas in accordance with the Design Drawings including, but not limited to: Excavation Areas, Cap Areas, staging areas, etc.
- 8.2 Protection of stakes. Contractor shall protect and preserve all of the established baseline stakes, benchmarks, or other controls placed by Sanborn Head. Any of these items destroyed or lost through fault of Contractor will be replaced by the Contractor at Contractor's expense.

9.0 Contractor's Obligations

- 9.1 Contractor's obligation is as follows: Contractor shall and in good manner, do and perform all Work and furnish and pay for all supplies and materials, machinery, equipment, facilities and means, except as herein otherwise expressly specified, necessary or proper to perform and complete all the Work required by this Contract, within the time stated in the proposal in accordance with the plans and drawings covered by this Contract, and any and all supplemental plans and drawings, in accordance with the directions of Owner's Representative as given from time to time during the progress of the Work, whether or not they consider the direction in accordance with the terms of the Contract. Contractor shall furnish, erect, maintain, and remove such construction plant and such temporary works as may be required. Contractor shall observe, comply with, and be subject to all terms, conditions,

requirements, and limitations of the Contract Documents, and shall do, carry on and complete the entire Work to the satisfaction of Owner's Representative and Owner.

- 9.2 Contractor shall carry on the Work and adhere to the progress schedule during all disputes, disagreements, or unresolved claims with Sanborn Head, Owner or NHDES. No Work shall be delayed or postponed pending the resolution of any disputes, disagreements, or claims except as Sanborn Head, Owner, NHDES, and Contractor may otherwise agree to in writing.

10.0 Weather Conditions

- 10.1 In the event of temporary suspension of Work, or during inclement weather, or whenever Owner's Representative shall indicate, Contractor and their Subcontractors shall protect their work and materials against damage or injury from the weather. If, in the opinion of Owner's Representative, any Work or material shall have been damaged or injured by reason of failure on the part of Contractor or any of their Subcontractors to so protect their work, such materials shall be removed and replaced at the expense of Contractor.

11.0 Protection of Work and Property

- 11.1 Contractor shall at all times safely guard the Owner's property from injury or loss in connection with this Contract. Contractor shall at all times safely guard and protect their own work, and that of adjacent property, from damage. Contractor shall replace or make good any such damage, loss or injury unless caused directly by errors contained in the Contract, or by Owner, or Owner's Representative. Contractor will notify owners of adjacent utilities when prosecution of the Work may affect them.
- 11.2 Contractor shall take all necessary precautions for the safety of employees on the Project site, and shall comply with all applicable provisions of federal, state and municipal safety laws and building codes to prevent accidents or injury to persons on, about or adjacent to the premises where the Work is being performed. Contractor shall erect and properly maintain at all times, as required by the conditions and progress of the Work, all necessary safeguards for the protection of the workers and the public and shall post danger signs warning against the hazards created by such features of construction as protruding nails, hoists, well holes, elevator hatchways, scaffolding, window openings, stairways, trenches and other excavations, and falling materials.
- 11.3 In case of emergency which threatens loss or injury of property, and/or safety of life, Contractor is allowed to act, without previous instructions from Owner's Representative. Contractor shall notify Owner's Representative immediately thereafter. Any claim for compensation by Contractor due to such extra work shall be promptly submitted in writing to Owner's Representative for approval.

- 11.4 When Contractor has not taken action but has notified Owner's Representative of an emergency threatening injury to persons or damage to the Work or any adjoining property, they shall act as instructed or authorized by Owner's Representative.
- 11.5 The intention is not to relieve Contractor from acting, but to provide for consultations between Owner's Representative and Contractor in an emergency which permits time for such consultations.
- 11.6 The amount of reimbursement claimed by Contractor on account of any emergency action shall be determined in the manner provided in Article 14 (Extra Work and Change Orders) of the General Conditions.

12.0 Inspection

- 12.1 For purposes of inspection and for any other purpose, Owner, Owner's Representative, and agents and employees of Owner or of any funding agency may enter upon the Work and the premises used by Contractor, and Contractor shall provide safe and proper facilities therefore. Owner's Representative shall be furnished with every facility for ascertaining that the Work is performed in accordance with the requirements and intention of this Contract, even to the extent of uncovering or taking down portions of finished Work.
- 12.2 During construction and on its completion, all Work shall conform to the location, lines, levels and grades indicated on the Drawings or established on the site by Owner's Representative and shall be built in accordance with the Drawings and Specifications and the supplementary directions given from time to time by Owner's Representative. In no case shall any Work which exceeds the requirements of the Drawings and Specifications be paid for as Extra Work unless ordered in writing by Owner's Representative.
- 12.3 Unauthorized work and work not conforming to Drawings and Specifications shall be handled as follows:
 - a. Work considered by Owner's Representative to be outside of or different from the Drawings and Specifications and done without instruction by Owner's Representative, or in wrong location, or done without proper lines or levels, may be ordered by Owner's Representative to be uncovered or dismantled.
 - b. Work done in the absence of Owner's Representative or their agent may be ordered by Owner's Representative to be uncovered or dismantled.
 - c. Should the Work thus exposed or examined prove satisfactory, the uncovering or dismantling and the replacement of material and rebuilding of

the Work shall be considered as "Extra Work" to be processed in accordance with Article 14.

- d. Should the Work thus exposed or examined prove to be unsatisfactory the uncovering or dismantling and the replacement of material and rebuilding of the Work shall be at the expense of Contractor.

13.0 Reports, Records and Data

- 13.1 Reports, records and data shall be furnished as follows: Contractor shall submit to Sanborn Head such schedule of quantities and costs, progress schedules, payrolls, reports, estimates, records and other data as are required by the Contract Documents or as Owner or any funding agency may request concerning Work performed or to be performed under this Contract.

14.0 Extra Work and Change Orders

- 14.1 Owner's Representative may at any time by written order and without notice to the Sureties require the performance of such Extra Work or changes in the Work as may be found necessary or desirable. The amount of compensation to be paid to Contractor for any Extra Work so ordered shall be made in accordance with whichever of the following plans Owner's Representative elects and which is approved in consultation with the Owner: (1) a price agreed upon between the parties and stipulated in the order for the Extra Work, or (2) a price based on the unit prices of the Contract.
- 14.2 Owner's Representative may authorize minor changes or alterations in the Work not involving extra cost and not inconsistent with the overall intent of the Contract Documents. These shall be accomplished by a written Field Order. However, if Contractor believes that any minor change or alteration authorized by Owner's Representative entitles them to an increase in the contract price, he may make a claim therefore as provided in Article 18.

15.0 Time for Completion and Liquidated Damages

- 15.1 It is hereby understood and mutually agreed, by and between Contractor and Owner and Sanborn Head, that the date of beginning and the time for completion as specified in the Contract of the Work to be done hereunder are Essential Conditions of this Contract; and it is further mutually understood and agreed that the Work embraced in this Contract shall be commenced on a date to be specified in the "Notice to Proceed."
- 15.2 Contractor agrees that said Work shall be pursued regularly, diligently, and continuously at such rate of progress as will ensure full completion thereof within the time specified. It is expressly understood and agreed, by and between

Contractor and Sanborn Head, that the time for the completion of the Work described herein is a reasonable time, taking into consideration the average climatic range and usual industrial conditions prevailing in this locality.

- 15.3 If Contractor shall neglect, fail or refuse to complete the Work within the time herein specified, or any proper extension thereof granted by Sanborn Head, funding agency, and Owner, then Contractor does hereby agree, as a part consideration for the awarding of this Contract, to pay to Sanborn Head the amount specified in the contract (\$1,500 for each day, in whole or in part, that expires after 60 calendar days from the date of mobilization), not as a penalty but as liquidated damages for such breach of Contract as hereinafter set forth, for each and every calendar day that Contractor shall be in default after the time stipulated in the contract for completing the Work.
- 15.4 The liquidated damages amount is fixed and agreed upon by and between Contractor and Sanborn Head because of the impracticability and extreme difficulty of fixing and ascertaining the actual damages Sanborn Head would in such event sustain. Said amount is agreed to be the amount of damages that Sanborn Head and/or Owner would sustain and said amount shall be deducted by Sanborn Head from current periodical payments.
- 15.5 It is further agreed that "time is of the essence" of each and every portion of this Contract and of the Specifications wherein a definite and certain length of time is fixed for the performance of any act whatsoever; and where under the Contract an additional time is allowed for the completion of any Work, the new time limit fixed by such extension shall "be of the essence". Provided, that Contractor shall not be charged with liquidated damages or any excess cost when Sanborn Head determines that Contractor is without fault and Contractor's reasons for the time extension are acceptable to Sanborn Head; provided, further, that Contractor shall not be charged with liquidated damages or any excess cost when the delay in the completion of the Work is due to:
- a. A preference, priority, or allocation order duly issued by the government;
 - b. An unforeseeable cause beyond the control and without the fault or negligence of Contractor, including, but not restricted to, acts of God, or of the public enemy, acts of Owner, acts of another Contractor in the performance of a Contract with Owner, fires, floods, epidemics, quarantine restrictions, strikes, freight embargoes, and severe weather;
 - c. Any delays of Subcontractors or suppliers occasioned by any of the causes specified in subsections (a) and (b) of this article.

- 15.6 Contractor shall promptly notify Sanborn Head in writing of the causes of the delay. Sanborn Head shall ascertain the facts and extent of the delay and notify Contractor within a reasonable time of their decision in the matter.

16.0 Defective Work

- 16.1 Contractor shall promptly remove from the premises all materials and Work condemned by Owner's Representative as failing to meet Contract requirements, whether incorporated in the Work or not, and Contractor shall promptly replace and re-execute their own Work in accordance with the Contract and without expense to Sanborn Head and funding agency and shall bear the expense of making good all Work of other Contractors which was destroyed or damaged by such removal or replacement.
- 16.2 All removal and replacement Work shall be done at Contractor's expense. If Contractor does not take action to remove such condemned Work and materials within ten (10) days after receipt of written notice, Sanborn Head or Owner may remove them and store the material at the expense of Contractor. If Contractor does not pay the expense of such removal and storage within ten (10) days' time thereafter, Sanborn Head or Owner may, upon ten (10) days written notice, sell such materials at auction or at private sale and shall pay to Contractor any net proceeds thereof, after deducting all the costs and expenses that should have been borne by Contractor, including expenses for moving, handling, and storage.

17.0 Claims for Differing Site Conditions

- 17.1 Contractor shall, upon discovery, and without further disturbance, notify Owner's Representative in writing of:
- a. Subsurface or latent physical conditions at the site differing materially from those indicated in this Contract; or,
 - b. Unknown physical conditions at the site, differing materially from those ordinarily encountered and generally recognized as inherent in the type of work provided for in this Contract.
- 17.2 Owner's Representative shall promptly investigate the conditions. If they find that conditions differ materially and will cause an increase or decrease in Contractor's cost or the time required to perform any part of the Work under this Contract, Owner's Representative, after consultation with Owner, shall make an equitable adjustment and modify the Contract in writing.
- 17.3 No claim of Contractor under this clause shall be allowed unless Contractor has given proper notice as required in Article 17.1 of this clause.

- 17.4 No claim by Contractor for an equitable adjustment shall be allowed if asserted after final payment under this Contract.

18.0 Claims for Extra Cost

- 18.1 No claim for extra work or cost shall be allowed unless the same was done pursuant to a written order by Owner's Representative, approved in consultation with Owner and/or funding agency, and the claim presented for payment with the first estimate after the changed or Extra Work is done.
- 18.2 If Contractor claims that any instructions by Drawings or similar documents issued after the date of the Contract involve extra cost under the Contract, they shall give Owner's Representative written notice after the receipt of such instruction and before proceeding to execute the Work, except in an emergency which threatens life or property, then the procedure shall be as provided for under Article 14, "Extra Work & Change Orders." No claim shall be valid unless so made.

19.0 Right of Sanborn Head to Terminate Contract

- 19.1 In the event that any of the provisions of this contract are violated by Contractor, or by any of their Subcontractors, Sanborn Head may serve written notice upon Contractor and the surety of its intention to terminate the Contract, and unless within 10 days after the serving of such notice upon Contractor, such violation or delay shall cease and satisfactory arrangement for correction be made, the Contract shall, upon the expiration of said ten (10) days cease and terminate. In the event of any such termination, Sanborn Head shall immediately serve notice thereof upon the surety and Contractor and the surety shall have the right to take over and perform the Contract; provided, however, that if the surety does not commence performance thereof within ten (10) days from the date of the mailing to such surety of notice of termination, Sanborn Head may take over the Work and prosecute the same to completion by Contract or by force account for and at the expense of Contractor and Contractor and their surety shall be liable to Sanborn Head for any excess cost occasioned by Sanborn Head, and in such event Sanborn Head may take possession of and utilize in completing the Work, such materials, appliances, and equipment as may be on the site of the Work and necessary therefore.
- 19.2 If Contractor should be adjudged bankrupt, or if make a general assignment for the benefit of their creditors, or if a receiver should be appointed on account of insolvency, or if they should refuse or should fail, except in cases for which extensions of time are provided, to supply enough skilled workers or materials, or if they should fail to make payments to Subcontractors or for material or labor, so as to affect the progress of the Work, or be guilty of a violation of the Contract, then Sanborn Head, when sufficient cause exists to justify such action may, without prejudice to any other right or remedy and after giving Contractor and their surety seven (7) days written notice, terminate the employment of Contractor and take

possession of the premises and of all materials, tools, equipment and other facilities installed on the Work and paid for by Sanborn Head, and finish the Work by whatever method they may deem expedient. In the case of termination of this Contract before completion from any cause whatever, Contractor, if notified to do so by Sanborn Head, shall promptly remove any part or all of their equipment and supplies at the expense of Contractor. If such expense exceeds such unpaid balance, Contractor shall pay the difference to Sanborn Head. The expense incurred by Sanborn Head as herein provided, and the damage incurred through Contractor's default, shall be approved by Owner's Representative.

- 19.3 Where the contract has been terminated by Sanborn Head, said termination shall not affect or terminate any of the rights of Sanborn Head as against Contractor or their surety then existing, or which may thereafter accrue because of such default. Any retention or payment of monies by Sanborn Head due Contractor under the terms of the Contract, shall not release Contractor or their surety from liability for default.
- 19.4 After ten (10) days from delivery of a Written Notice to Contractor, Sanborn Head may, without cause and without prejudice to any other remedy, elect to abandon the Project and terminate the Contract. In such case, Contractor shall be paid for all Work executed and any expense sustained plus reasonable profit.
- 19.5 If the performance of all or any portion of the Work is suspended, delayed, or interrupted as a result of failure of Owner or Owner's Representative to act within the time specified in the Contract Documents, or if no time is specified, within a reasonable time, an adjustment in the Contract Price or an extension of the Contract Time, or both, shall be made by Change Order to compensate Contractor for the costs and delays necessarily caused by the failure of Owner or Owner's Representative.

20.0 Payments to Contractor

- 20.1 Progress Payments: Sanborn Head will make a progress payment to Contractor on the basis of an estimate of the total amount of work done, the time of the estimate and its value as prepared by Contractor and approved by Owner's Representative.
- 20.2 The Progress Payment will be paid by Sanborn Head after Sanborn Head receives funds from NHDES.
- 20.3 Retainage by Sanborn Head: Sanborn Head will retain a portion of the progress payment, each month, in accordance with the following procedures:
- a. Retainage shall be 10% of the monthly payments claimed.

- b. Upon substantial completion (as defined in Article 21), and provided Contractor has satisfied Owner's Representative in quality and timeliness of the work, and provided further that there is no specific cause for withholding the full retainage, half of the amount of retainage withheld will be paid to Contractor. The remaining retainage shall be held during the one-year warranty period and released only after NHDES and Sanborn Head have accepted the project and all Contract requirements and documents have been met and submitted.
- 20.4 In reviewing monthly estimates for payments of the value of Work done, Owner's Representative may accept in the estimate, prior to subtracting the retainage, the delivered cost of certain equipment and nonperishable material which have been delivered to the site or off-site location and which are properly stored and protected from damage. With the estimate, Contractor shall submit to Owner's Representative invoices as evidence that the material has been delivered to the site. Prior to submitting the next monthly estimate, Contractor shall provide Owner's Representative with paid invoices or other evidence that the materials have been paid for. If Contractor fails to submit such evidence, Owner's Representative may then subtract the value of such materials or equipment for which NHDES has previously paid, from the next monthly estimate. The type of equipment and material eligible for payment prior to being incorporated in the Work will be at Owner's Representative's discretion. Material and equipment made specifically for the subject job will be eligible for payment.
- 20.5 All material and Work for which partial payments have been made shall thereupon become the sole property of Owner. This provision shall not be construed as relieving Contractor from the sole responsibility for the care and protection of materials and Work upon which payments have been made or for the restoration of any damaged Work, or as a waiver of the right of Sanborn Head to require compliance with all of the terms of the Contract.
- 20.6 Sanborn Head's right to withhold payments and make application. Contractor agrees that they will save Owner, Sanborn Head, funding agency, and Owner's agents harmless from all claims growing out of the lawful demands of Subcontractors, laborers, workmen, mechanics, material men, and furnishers of machinery and parts, equipment, power, tools and all supplies, including commissary, incurred in the furtherance of the performance of this Contract. Contractor shall, at Sanborn Head's request, furnish satisfactory evidence that all claims of the nature hereinabove designated have been paid, discharged, or waived. If Contractor fails to do so, then Sanborn Head may, upon written notice to Contractor either pay unpaid bills of which Sanborn Head has Written Notice directly, or withhold from Contractor's unpaid compensation a sum of money to pay any and all such lawful claims until satisfactory evidence is furnished that all liabilities have been fully discharged. Payment to Contractor shall then be resumed in accordance with the terms of this Contract but in no event shall the above provisions be construed to

impose any obligations upon Sanborn Head to either Contractor or their surety or any third party. In paying any unpaid bills of Contractor, Owner or Sanborn Head shall be deemed the agent of Contractor, and any payment so made by Owner or Sanborn Head shall be considered as payment made under contract by Sanborn Head to Contractor and Sanborn Head shall not be liable to Contractor for any such payments made in good faith.

- 20.7 If Sanborn Head fails to make payment forty-five (45) days after receipt of funds from Owner, in addition to other remedies available to Contractor, there shall be added to each such payment interest at an annual rate of 5% commencing on the first day after said payment is due and continuing until the payment is received by Contractor.

21.0 Acceptance and Final Payment

21.1 Substantial completion and payment.

- a. Substantial completion shall be that point, as approved by Owner's Representative, at which the Contract has been completed to the extent that Owner may occupy and/or make use of the Work performed for the purposes for which it was intended. Upon substantial completion, there may be minor items, such as seeding, landscaping, etc., yet to be completed or items of Work to be corrected.
- b. Upon receipt of Written Notice from Contractor that the Work is substantially complete, Owner's Representative shall promptly make an inspection, and when they find the Work complies with the terms of the Contract and the contract is substantially completed, they will issue a signed and dated certificate, and a list of all items to be completed or corrected, stating that the Work required by this Contract has been substantially completed and is accepted.
- c. Upon substantial completion, the entire balance due and payable to Contractor less 5 percent of the Contract Price, and less a retention based on Owner's Representative's estimate of the fair value for the cost of completing or correcting listed items of Work with specified amounts for each incomplete or defective item of Work shall be made.
- d. The general guarantee period for the Work shall begin on the Final Completion date as approved by Owner's Representative.

- 21.2 Final Completion shall be that point at which all Work has been completed and all defective Work has been corrected.

- 21.3 At the end of the general guarantee period for the entire Contract which has been certified finally completed or substantially completed, Sanborn Head shall make an inspection of all or portions of the Work. When it is found that the Work is satisfactory and that no Work has become defective under the terms of the Contract, Sanborn Head will accept the entire project and make final payment, including the reimbursement of monies retained pursuant to the guarantee period.
- 21.4 If the guarantee inspection discloses any Work as being unsatisfactory, Owner's Representative will give Contractor the necessary instructions for correction of such Work, and Contractor shall immediately execute such instructions. Upon correction of the Work, another inspection will be made which shall constitute the guarantee inspection, provided the Work has been satisfactorily completed.
- 21.5 Before issuance of final payment, Contractor shall certify in writing to Owner's Representative that all payrolls, material bills, and other indebtedness connected with the Work have been paid or otherwise satisfied.
- 21.6 If upon substantial completion, Final Completion is delayed through no fault of Contractor, and Owner's Representative so certifies, Sanborn Head may, without termination of the Contract, make payment of the balance due for that portion of the Work fully completed and accepted. Such payment shall be made under the terms and conditions governing final payment, except that it shall not constitute a waiver of claims.
- 21.7 The acceptance by Contractor of final payment shall release Sanborn Head and Owner from all claims and all liability to Contractor for all things relating to this Work and for every act and neglect of Sanborn Head and Owner and others relating to or arising out of this Work. No payment, however, final or otherwise, shall operate to release Contractor or their sureties from any obligations of the Performance and Payment Bonds under this Contract.

22.0 Insurance

- 22.1 Contractor shall procure and shall maintain during the life of this Contract all insurance required under this article. Owner, Sanborn Head, and Owner's Representatives shall be named as additional insured parties on all General Liability policies. The minimum limits of liability of such insurance shall be as follows:
- a. Commercial General Liability insurance to include contractual liability, explosion, collapse, underground coverages, property damage liability, and personal injury liability of not less than \$2,000,000 for each occurrence (bodily injury and property damage) and a \$5,000,000 minimum aggregate amount.

- b. Statutory Workers' Compensation insurance, and Employer's Liability insurance of at least \$1,000,000 each accident.
- c. Comprehensive automobile liability insurance to include all motor vehicles including owned, hired, borrowed, and non-owned vehicles. Minimum Limits of liability: \$1,000,000 combined single limit for bodily injury and property damage.
- d. Contractor's Pollution Liability with a limit of at least \$2,000,000 per claim and \$4,000,000 in aggregate.

22.2 Contractor shall either:

- a. Require each of his Subcontractors to procure and to maintain during the life of their subcontract commercial general liability insurance and comprehensive automobile liability insurance of the type and in the amounts specified in Articles 22.1.a and 22.1.c; or
- b. Insure the activities of their Subcontractors in his policy.

22.3 The required insurance shall provide adequate protection for Contractor and his Subcontractors, respectively, against damage claims that may arise from Work under this Contract, whether such Work be by the insured or by anyone employed by them and also against any of the special hazards that may be encountered in the performance of this Contract.

22.4 Contractor shall furnish Sanborn Head with certificates showing the type, amount, class of operations covered, effective dates and dates of expiration of policies. Such insurance shall not be canceled or materially altered, except after ten (10) days Written Notice has been received by Sanborn Head and Owner.

22.5 The policies shall be on forms and endorsements approved for use in the State of New Hampshire by the New Hampshire Department of Insurance and issued by insurers licensed in the State of New Hampshire.

23.0 Bonds

23.1 None of the three lowest qualified Bids shall be deemed rejected, notwithstanding acceptance of one of the Bids, until the Contract has been executed by both Sanborn Head and the accepted Bidder.

23.2 Contractor shall within seven (7) business days after the receipt of the Notice of Award furnish Sanborn Head with a Performance Bond and a Payment Bond in penal sums equal to the amount of the Contract Price conditioned upon the performance by Contractor of all undertakings, covenants, terms, conditions and agreements of the Contract Documents, and upon the prompt payment by Contractor to all persons

supplying labor and materials in the prosecution of the Work provided by the Contract Documents. Such Bonds shall be executed by Contractor and a corporate bonding company licensed to transact business in the state in which the Work is to be performed and named on the current list of "Surety Companies Acceptable on Federal Bonds" as published in the Treasury Department Circular Number 570. The expense of these Bonds shall be borne by Contractor.

- 23.3 In the event the successful Bidder fails to execute and deliver the Agreement and to furnish the required contract security and insurance certificates within seven business days of the Notice of Award Owner's Representative may annul the Notice of Award of that Bidder shall be forfeited as liquidated damages.
- 23.4 In the event the successful Bidder has failed to fulfill such promises (and subject to Sanborn Head's right to reject all Bids), Owner's Representative shall issue the Notice of Award to the next lowest responsive, responsible qualified Bidder. Any Bidder so awarded a Contract shall fulfill every stipulation embraced herein as if they were the original party to whom the award was made.
- 23.5 Attorneys-in-fact who sign Performance Bonds or Payment Bonds must file with each Bond a certified and effective dated copy of their power of attorney.

24.0 Subcontracting

- 24.1 Contractor may utilize the services of specialty Subcontractors on those parts of the Work that, under usual contracting practices, are performed by specialty Subcontractors.
- 24.2 Contractor shall be as fully responsible to Sanborn Head for the acts and omissions of their Subcontractors, and of persons either directly or indirectly employed by them, as they are for the acts and omissions of persons directly employed by them.
- 24.3 Contractor shall cause appropriate provisions to be inserted in all subcontracts relative to the Work to bind Subcontractors to Contractor by the terms of the contract documents insofar as applicable to the Work of Subcontractors and to give Contractor the same power as regards terminating any subcontract that Sanborn Head may exercise over Contractor under any provision of the Contract Documents.
- 24.4 Contractor shall not create any contractual relation between any Subcontractor and Sanborn Head or Owner.
- 24.5 Contractor shall not award Work to Subcontractor(s) where the combined value of all subcontracted Work exceeds 50% of the Contract Price, not including transportation and disposal of remediation waste, without prior written consent of Sanborn Head.

25.0 Authority of Owner's Representative

25.1 Owner's Representative shall have the authority to suspend the Work in whole or in part for such periods as they may deem necessary due to the failure of Contractor to carry out provisions of the Contract or for failure of Contractor to suspend Work in weather conditions considered by Owner's Representative to be unsuitable for the prosecution of the Work. Owner's Representative shall give all orders and directions under this Contract, relative to the execution of the Work. Owner's Representative shall determine the amount, quality, acceptability, and fitness of the kinds of work and materials which are to be paid for under this Contract and shall decide all questions which may arise in relation to the Work. Owner's Representative's estimates and decisions shall be final and conclusive, except as otherwise provided. In case any question shall arise between the parties hereto relative to said Contract or Specifications, the determination or decision of Owner's Representative shall be a condition precedent to the right of Contractor to receive any money or payment for Work under this Contract affected to any extent by such question. Owner's Representative shall decide the meaning and intent of any portion of the Specifications and of any Drawings where the same may be found unclear. Any differences or conflicts in regard to their Work which may arise between Contractor under this Contract and other Contractors performing Work for Owner shall be adjusted and determined by Owner's Representative.

- a. The purpose of the above article is not in any way to relieve Contractor of their responsibilities for the safety of workers or general public in the execution of the Work. Attention is drawn to Article 32 of these Conditions that refers to the safety obligations of Contractor.
- b. Owner's Representative, acting on behalf of Owner, has the authority to enforce corrective action for Work not in accordance with the Specifications.
- c. In addition, Owner's Representative, acting on behalf of Owner, is to attempt to verify that the Work is in accordance with the Contract Documents. Owner's Representative is not held responsible, however, for the methods of construction, sequences, schedules, and procedures in the execution of the Work. Owner's Representative does have the opportunity under Article 25.1 to reject the method of construction, work plan schedule, procedures, as they think appropriate.

25.2 Owner's Representative shall appoint assistants and representatives as they desire, and they shall be granted full access to the Work under the Contract. They have the authority to give directions pertaining to the Work, to approve or reject materials, to suspend any Work that is being improperly performed, to make measurements of quantities, to keep records of costs, and otherwise represent Owner's Representative in all matters except as provided below. Contractor may, however, appeal from their decision to Owner's Representative, but any Work done pending

its resolution is at Contractor's own risk. Except as permitted and instructed by Owner's Representative, the assistants and representatives are not authorized to revoke, alter, enlarge, relax, or release any requirements of these Specifications, nor to issue instructions contrary to the Drawings and Specifications. They are not authorized to act as superintendents or foremen for Contractor, or to interfere with the management of the Work by Contractor. Any advice which the assistants or representatives of Owner's Representative may give Contractor shall not be construed as binding Owner's Representative or Owner in any way, nor as releasing Contractor from the fulfillment of the terms of the Contract. All transactions between Contractor and the representatives of Owner's Representative which are liable to protest or where payments are involved shall be made in writing.

26.0 Use of Premises, Removal of Debris, Sanitary Conditions

26.1 In the use of premises or removal of debris, Contractor expressly undertakes at their own expense: to take every precaution against injuries to persons or damage to Property; to maintain sanitary conditions; to store apparatus, materials, supplies and equipment in such orderly fashion at the site of the Work as will not interfere with the progress of Work or the Work of any others; to place upon the Work or any part thereof only such loads as are consistent with the safety of that portion of the Work; to clean up frequently all refuse, rubbish, scrap materials and debris caused by Contractor's operations, to the end that at all times the site of the Work shall present an orderly and workmanlike appearance; before final payment to remove all surplus material falsework, temporary structures, including foundations thereof, plant of any description and debris of every nature resulting from Contractor's operations, and to put the site in an orderly condition; to effect all cutting, fitting or patching of Work required to make the same conform to the Drawings and Specifications and, except with the consent of Owner's Representative, not to cut or otherwise alter the Work of any others; to provide and maintain in a sanitary condition such toilet accommodations for the use of employees as may be necessary to comply with the requirements of the state and local boards of health, or of other bodies or authorities having jurisdiction.

27.0 Estimated Quantities

27.1 Owner's Representative's estimated quantities are indicated on the Bid Schedule. Actual quantities may vary from those indicated. The total Bid Price for each item shall be based on the quantities indicated on the Bid Schedule where provided, or as estimated by Contractor where not provided. No adjustment, either up or down, in unit price for an individual pay item will be considered unless the actual quantity of the pay item required to complete the Work varies by greater than twenty five percent (25%) from that indicated on the Bid Schedule. Claims for Extra Work resulting from changed quantities shall be processed under Article 18.

- 27.2 Should any unit priced item contained on the Bid Schedule be found unnecessary for the proper completion of the Work, Owner's Representative may eliminate such item from the contract and such action shall in no way invalidate this Agreement.

28.0 General Guaranty

- 28.1 With reference to warranties, neither the final certificate of payment nor any provision in the Contract Documents, nor partial or entire occupancy of the premises by Owner, shall constitute an acceptance of Work not done in accordance with the Contract Documents or relieve Contractor of liability in respect to any express warranties or responsibility for faulty materials or workmanship. Contractor shall remedy any defects in the Work and pay for any damage to other Work resulting therefrom, which appear within the warranty period one year or longer if required by the contract, from the certified date of completion or substantial completion of the Work. Sanborn Head will give notice of observed defects within five working days of their discovery.

29.0 Errors and Inconsistencies in Contract Documents

- 29.1 With reference to errors and inconsistency in Contract Documents, any provisions in any of the Contract Documents which may be in conflict with the paragraphs in these General Conditions shall be subject to the following order of precedence for interpretation:
- a. Drawings will govern technical specifications.
 - b. General Conditions will govern Drawings and Technical Specifications.
 - c. Supplemental Conditions will govern General Conditions, Drawings, and Technical Specifications.
- 29.2 Contractor shall take no advantage of any apparent error or omission in the Drawings or Specifications. In the event Contractor discovers such an error or omission, they shall notify Owner's Representative. Owner's Representative will then make such corrections and interpretations as may be deemed necessary for fulfilling the intent of the Drawings and Specifications.

30.0 Notice and Service Thereof

- 30.1 Any notice to Contractor from Sanborn Head relative to any part of this Contract will be in writing and will be considered delivered and the service completed, when said notice is mailed, by email or by certified registered mail, to Contractor at their last given address, or delivered in person to Contractor or their authorized representative on the Work.

31.0 Required Provisions Deemed Inserted

31.1 Each and every provision of law and clause required by law to be inserted in this Contract shall be deemed to be inserted herein and the Contract shall be read and enforced as though it were included herein, and if through mistake or otherwise any such provision is not inserted or is not correctly inserted (example; miswording, etc.), then upon the application of either party the Contract shall forthwith be physically amended to make such insertion or correction.

32.0 Health and Safety Responsibilities

- 32.1 Contractor shall at all times be responsible for the activities of their own employees and agents on the job site with respect to job site safety.
- 32.2 Contractor shall acknowledge its understanding regarding its health and safety responsibilities by reading and signing the “Contractor’s Statement of Understanding Regarding Health and Safety Responsibilities” contained in Exhibit A. Contractor shall comply with all applicable provisions of federal, state, and local health, safety, and training obligations required by law, including 29 CFR Parts 1910 and 1926. Compliance with these health, safety, and training requirements and any other safety practices deemed necessary by Contractor is the sole responsibility of Contractor. Sanborn Head is not in any way responsible for the health, safety, or training of Contractor’s employees.
- 32.3 Contractor warrants that all of its employees who are permitted to engage in hazardous waste operations that could expose them to hazardous substances, safety, or health hazards have obtained the necessary health and safety training and medical surveillance in compliance with 29 CFR 1910.120. Failure to comply with general health and safety practices may be grounds for termination.
- 32.4 Contractor shall prepare a project specific Health and Safety Plan for use by all its employees engaged in the Work. Contractor shall review the plan with all on-site employees and other personnel prior to starting the Work. Contractor shall see that their Subcontractors and vendors are aware of the health and safety risks associated with completion of this project.

33.0 Compliance by Contractor with Laws and Regulations: Equal Employment Opportunity

- 33.1 In connection with the performance of the services, Contractor shall comply with all statues, laws, regulations, and orders of federal, state, county, or municipal authorities which impose any obligation or duty upon Contractor, including, but not limited to civil rights and equal opportunity laws.
- 33.2 During the term of this Agreement, Contractor shall not discriminate against employees or applicants for employment because of race, color, religion, creed, age,

sex, handicap, or national origin, and will take affirmative action to prevent such discrimination.

34.0 Pre-Construction Meeting

34.1 Contractor shall not commence Work until a pre-construction meeting has been held at which representatives of Contractor and Owner's Representative are present. The pre-construction meeting shall be scheduled by Owner's Representative.

35.0 Work Performed at Night and on Weekends and Holidays

35.1 No Work will be permitted at night or on weekends or holidays except as approved in writing by Owner's Representative, and provided such Work is not in violation of a local ordinance. When working at night, Contractor shall provide flood lighting sufficient to ensure the same quality of workmanship and the same conditions regarding safety as would be achieved in daylight.

35.2 Whenever a federal holiday (e.g., Memorial Day or Fourth-of-July) is observed on a Friday or a Monday and during the weekend, Contractor may be required to suspend Work for the 3 calendar days. Prior to the close of Work, the Project site shall be placed in a condition acceptable to Owner's Representative for the comfort and safety of the traveling public. An arrangement shall be made for responsible personnel acceptable to Owner's Representative to maintain the project in the above conditions.

36.0 Laws, Permits, Rules and Ordinances

36.1 Contractor shall keep fully informed of all federal and state laws, all local laws, ordinances, and regulations, and all orders and decrees of tribunals having any jurisdiction or authority, which in any manner affect those engaged or employed on the Work. Contractor shall at all times observe and comply with all such laws, ordinances, regulations, orders, and decrees; and shall protect and indemnify Owner, Sanborn Head & Associates, Inc., and their subcontractors and representatives against any claim or liability arising from or based on the violation of any such law, ordinance, regulation, order, or decree, whether by themselves or their employees. Such laws, rules, and regulations are listed throughout these Contract Documents, and include but are not limited to the New Hampshire Code of Administrative Rules Env-Or 600 Contaminated Site Management, and the New Hampshire Hazardous Waste Rules Env-Wm 500.

36.2 All permits and licenses necessary for the performance of the Work, including coverage under the USEPA National Pollutant Discharge Elimination System (NPDES) Construction General Permit (CGP) for Stormwater Discharges from Construction Sites, including submittal of the Notice of Intent (NOI), shall be obtained by

Contractor. The Contractor may also be responsible for obtaining additional permits that are required as part of the Contract with Streamworks, PLLC.

37.0 Indemnification

- 37.1 To the fullest extent permitted by laws and regulations, Contractor will defend, indemnify, and hold harmless Owner, Sanborn, Head & Associates, Inc., and their consultants, agents, separate contractors and employees from and against all claims, damages, losses, and expenses, direct, indirect or consequential (including but not limited to fees and charges of Engineers, architects, attorneys, and other professionals and court and arbitration costs) arising out of or resulting from the performance of the Work, provided that any such claims, damage, loss or expense is attributable to bodily injury, sickness, disease or death, or to injury to or destruction of tangible property (other than the Work itself) including the loss of use resulting therefrom; and is caused in whole or in part by any negligent or willful act or omission or breach of Contract by Contractor, and Subcontractor, vendor, or anyone directly or indirectly employed by any of them to perform or furnish any of the Work or anyone for whose acts any of them may be liable.
- 37.2 In any and all claims against Owner or Owner's Representative, or any of their agents of employees, by any employees of Contractor, and Subcontractor, anyone directly or indirectly employed by any of them, or anyone for whose acts any of them may be liable, the indemnification obligation shall not be limited in any way by any limitation on the amount or type of damages, compensation or benefits payable under workers' or workman's compensation acts, by disability benefit or other employee benefit acts, and shall survive final completion and acceptance of the Work.

P:\4000s\4088.012\Source Files\Bid Documents\Contracting Documents\202511-GeneralConditions.docx

**EXHIBIT A
TO GENERAL CONDITIONS
FOR CONTRACTOR SERVICES**

**CONTRACTOR'S STATEMENT OF UNDERSTANDING
REGARDING HEALTH AND SAFETY RESPONSIBILITIES**

Each Contractor employed by Sanborn, Head & Associates, Inc. (Sanborn Head) is responsible for all aspects of the health and safety of its employees and equipment, including identification of possible health and safety issues related to the project. Sanborn Head will make its health and safety plan available to each Contractor. This health and safety plan will be provided for informational purposes only, however, and each Contractor (including subcontractors) is responsible for developing its own health and safety program for its activities on site.

Contractor confirms that all its on-site employees are certified to work at sites where there is a potential for exposure to hazardous substances, or other potential health and safety hazards. Contractor also confirms that these employees have had the proper health and safety training and are involved in an appropriate medical monitoring program pursuant to OSHA:

1910.120 Hazardous Waste Operations and Emergency Response
1926.103 Respiratory Protection
1926.52 Occupational Noise Protection
1926.59 Hazard Communication

and any other applicable portions of OSHA. Contractor shall provide at Sanborn Head's request copies of all applicable certification prior to commencement of work.

If it comes to the attention of Sanborn Head, that Contractor's site activities are in violation of OSHA or other applicable regulations or pose a danger to the health or safety of on-site personnel or the general public, Sanborn Head may inform Contractor of the need to correct such activities. If Contractor does not comply with general health and safety procedures or those specified above, Sanborn Head may terminate its Agreement with Contractor immediately.

It should be clearly noted that the presence of Sanborn Head personnel at the site does not indicate that Sanborn Head is responsible to ensure or oversee that Contractor complies with appropriate health and safety requirements.

Signatory indicates that he/she is authorized to endorse this agreement for Contractor:

Firm: _____

Name (Print): _____

Title: _____

Signature: _____

Date: _____

Supplemental Conditions

SUPPLEMENTAL CONDITIONS

**Brownfields Cleanup
Former Woods Woolen Mill
23-25 West Mill Street, Hillsborough, New Hampshire
NHDES Site #: 199909015**

This section provides additional conditions to supplement the general conditions.

1.0 Contract and Contract Documents

This Agreement, which may be executed in a number of counterparts, each of which shall be deemed an original, constitutes the entire Agreement and understanding between the parties, and supercedes all prior agreements and understanding.

This Agreement shall be construed in accordance with the laws of the State of New Hampshire, and is binding upon and inures to the benefit of the parties and their respective successors and assigns.

2.0 Federal Requirements

The Contractor shall comply with the regulations of the Build America Buy America Act and shall cause appropriate provisions to be inserted in subcontracts to ensure compliance therewith by all subcontractors subject thereto.

P:\4000s\4088.012\Source Files\Bid Documents\Contracting Documents\202511-SupplementalConditions.docx

ATTACHMENTS

Construction Design Drawings

CONSTRUCTION DESIGN DRAWINGS FORMER WOODS WOOLEN MILL SITE

23-25 WEST MILL STREET
HILLSBOROUGH, NEW HAMPSHIRE
NHDES SITE NO: 19990915
DECEMBER 2025

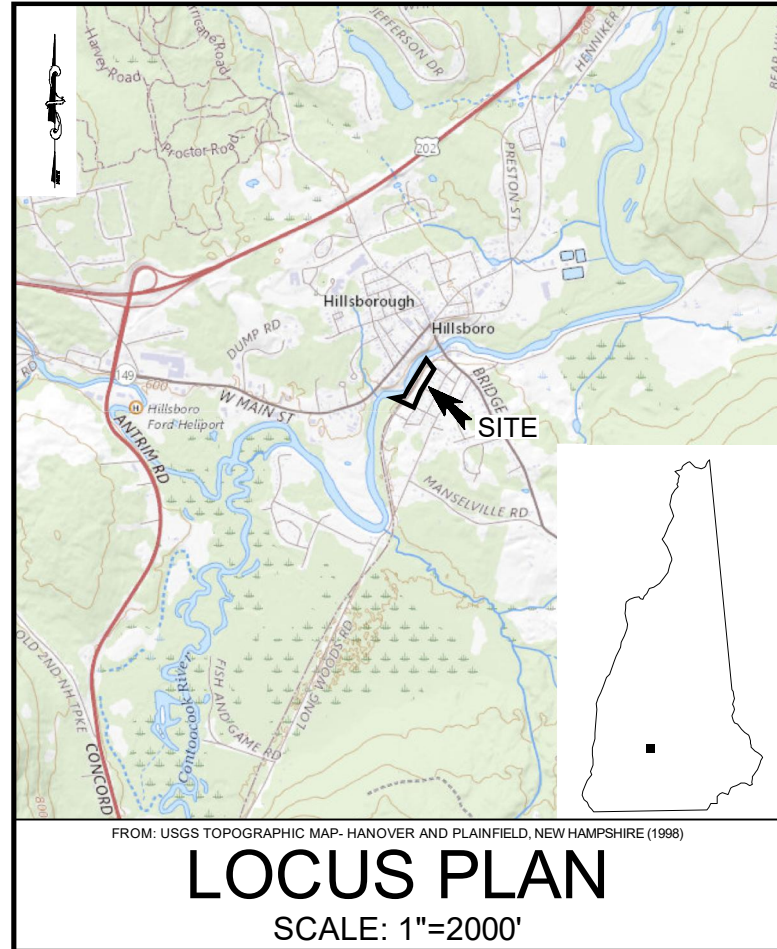

SHEET INDEX

SHEET 1	EXISTING CONDITIONS PLAN
SHEET 2	EROSION AND SEDIMENT CONTROL PLAN
SHEET 3	PROPOSED EXCAVATION PLAN
SHEET 4	FINAL GRADING PLAN
SHEET 5	SOIL CAP TRANSITION AND EROSION CONTROL DETAILS

REVISION TABLE			
NO.	DATE	DESCRIPTION	BY

PREPARED FOR:

NEW HAMPSHIRE DEPARTMENT OF ENVIRONMENTAL SERVICES
CONCORD, NEW HAMPSHIRE

PREPARED BY:



6 BEDFORD FARMS DRIVE, BEDFORD, NEW HAMPSHIRE 03110
(603) 229-1900 FAX (603) 229-1919

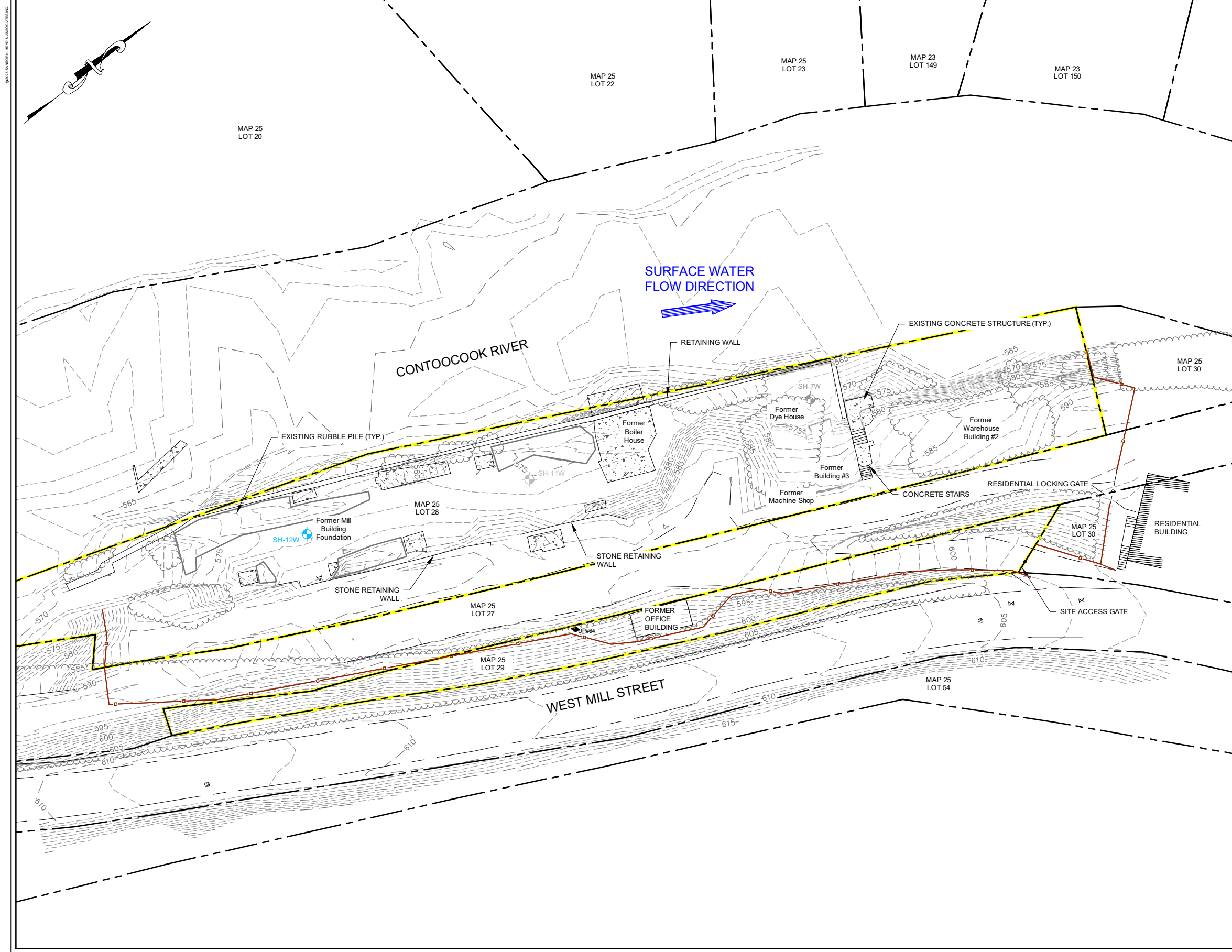

- NOTES:**
1. THIS PLAN WAS PREPARED FROM A COMBINATION OF AN ACTUAL ON THE GROUND SURVEY, HYDROGRAPHIC SURVEY AND UNMANNED AERIAL SURVEY CONDUCTED BY WSP USA, INC. OF MERRIMACK, NEW HAMPSHIRE IN JANUARY 2024 AND FEBRUARY 2024, AND A SUPPLEMENTAL SURVEY CONDUCTED BY STREAMWORKS PLLC (NOT A LICENSED SURVEYOR) OF MADBURY, NEW HAMPSHIRE.
 2. THE HORIZONTAL DATUM SHOWN HEREON REFERENCES THE NORTH AMERICAN DATUM OF 1983, MASSACHUSETTS STATE PLANE MAINLAND COORDINATE SYSTEM AND WAS ESTABLISHED UTILIZING RTK GPS SURVEY TECHNIQUES REFERENCING THE MACORS GPS NETWORK.
 3. THE VERTICAL DATUM SHOWN HEREON REFERENCE NAVD 1988.
 4. BOUNDARY LINES SHOWN HEREON ARE TO BE CONSIDERED APPROXIMATE AND ARE NOT THE RESULTS OF AN ACTUAL BOUNDARY SURVEY.

- LEGEND:**
- 5-FT CONTOUR LINE
 - 1-FT CONTOUR LINE
 - EXISTING FENCE
 - GUARDRAIL
 - GATE
 - APPROX. ABUTTERS LOT LINE
 - EDGE OF GRAVEL
 - APPROXIMATE SITE BOUNDARY
 - SEWER MANHOLE
 - WATER VALVE
 - UTILITY POLE
 - RETAINING WALL
 - EDGE OF PAVEMENT
 - TREELINE
 - APPROXIMATE AREA OF RUBBLE
 - BUILDING
 - APPROXIMATE LOCATION OF CONCRETE STRUCTURE
 - CULVERT OUTLET
 - SANBORN HEAD MONITORING WELL TO BE REMOVED AS PART OF CONSTRUCTION
 - SANBORN HEAD MONITORING WELL PRESUMED DESTROYED

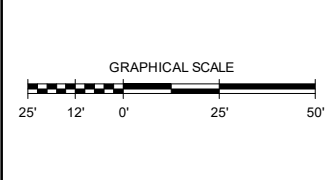

NO.	DATE	DESCRIPTION	BY

DRAWN BY: B. DAILEY
 DESIGNED BY: B. DAILEY / C. VIGNOLA
 REVIEWED BY: H. CAPROOD
 PROJECT MGR: H. CAPROOD
 PIC: J. SANBORN
 DATE: DECEMBER 2025

CONSTRUCTION DESIGN DRAWINGS
FORMER WOODS WOOLEN MILL
 HILLSBOROUGH, NEW HAMPSHIRE
EXISTING CONDITIONS PLAN

PROJECT NUMBER:
4088.012
 SHEET NUMBER:
1 OF 5

MAP 25 LOT 20, MAP 25 LOT 22, MAP 25 LOT 23, MAP 23 LOT 149, MAP 23 LOT 150, MAP 25 LOT 28, MAP 25 LOT 27, MAP 25 LOT 29, MAP 25 LOT 30, MAP 25 LOT 54, WEST MILL STREET, CONTOOCCOOK RIVER, SURFACE WATER FLOW DIRECTION, RETAINING WALL, EXISTING RUBBLE PILE (TYP.), Former Mill Building Foundation, SH-12W, Former Boiler House, Former Dye House, Former Warehouse Building #2, Former Machine Shop, CONCRETE STAIRS, RESIDENTIAL LOCKING GATE, RESIDENTIAL BUILDING, STONE RETAINING WALL, FORMER OFFICE BUILDING, SITE ACCESS GATE, EXISTING CONCRETE STRUCTURE (TYP.), SH-11W

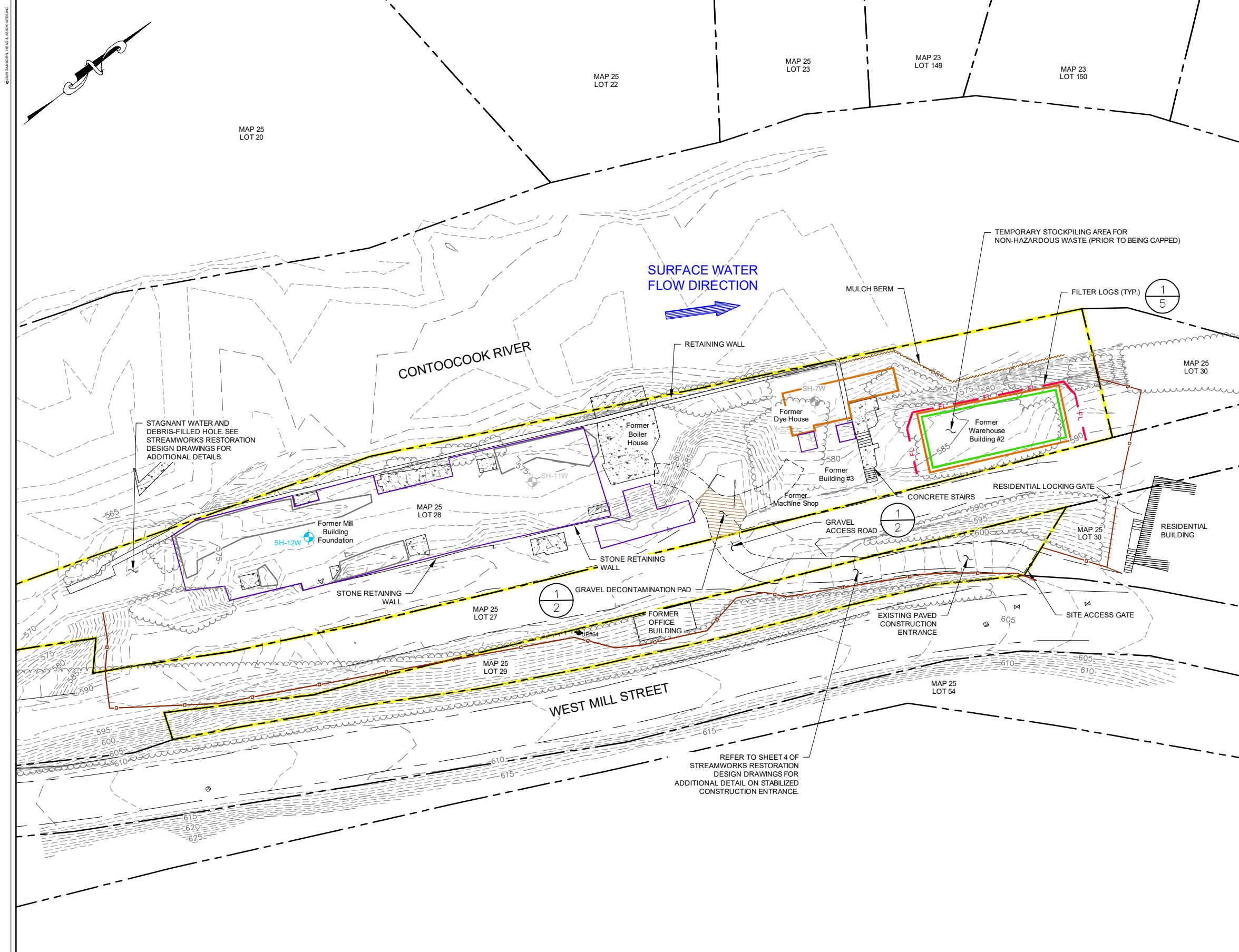

- NOTES:**
- SEE SHEET 1 FOR ADDITIONAL NOTES AND LEGEND.
 - SEE SECTION 01 50 00 - TEMPORARY FACILITIES AND CONTROLS FOR ADDITIONAL INFORMATION REGARDING TEMPORARY AND EXISTING FENCING INFORMATION.
 - SEE SECTION 01 57 13 - TEMPORARY EROSION AND SEDIMENT CONTROL FOR ADDITIONAL INFORMATION REGARDING TEMPORARY EROSION AND SEDIMENT CONTROL.
 - REFER TO STREAMWORKS RESTORATION DESIGN DRAWINGS FOR ADDITIONAL EROSION CONTROL MEASURES.

- LEGEND:**
- PROPOSED CAP LIMIT
 - EDGE OF PAVEMENT
 - PROPOSED EDGE OF GRAVEL ACCESS ROAD
 - PROPOSED FILTER LOG
 - PROPOSED MULCH BERM
 - APPROXIMATE EXCAVATION AREA WITH OFF-SITE SOIL DISPOSAL
 - TEMPORARY STOCKPILING AREA FOR NON-HAZARDOUS WASTE (PRIOR TO BEING CAPPED)
 - PROPOSED GRAVEL DECONTAMINATION PAD

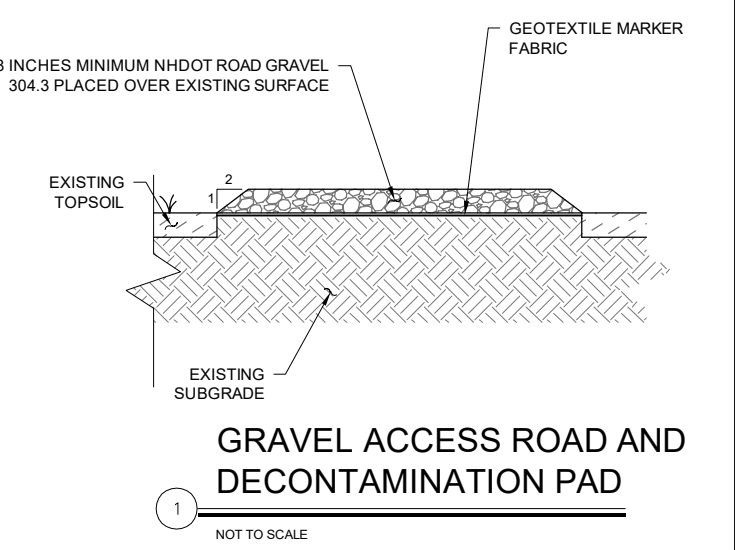

SANBORN HEAD & ASSOCIATES, INC. 1000 WASHINGTON STREET, SUITE 200, BOSTON, MA 02108
 PROJECT: 2025-001 - FORMER WOODS WOOLEN MILL
 DRAWING: EROSION AND SEDIMENT CONTROL PLAN
 DATE: 12/15/2025
 SCALE: AS SHOWN
 FILE: P:\2025\2025-001\Drawings\ESCP\2025-001-ESCP-02.dwg
 LAYOUT: ESCP
 PLOT DATE: 12/15/2025 10:45 AM

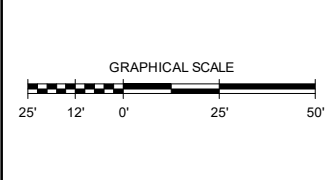

NO.	DATE	DESCRIPTION	BY

DRAWN BY: B. DAILEY
 DESIGNED BY: B. DAILEY / C. VIGNOLA
 REVIEWED BY: H. CAPROOD
 PROJECT MGR: H. CAPROOD
 PIC: J. SANBORN
 DATE: DECEMBER 2025

CONSTRUCTION DESIGN DRAWINGS
FORMER WOODS WOOLEN MILL
 HILLSBOROUGH, NEW HAMPSHIRE
EROSION AND SEDIMENT CONTROL PLAN

PROJECT NUMBER:
 4088.012
 SHEET NUMBER:
 2 OF 5

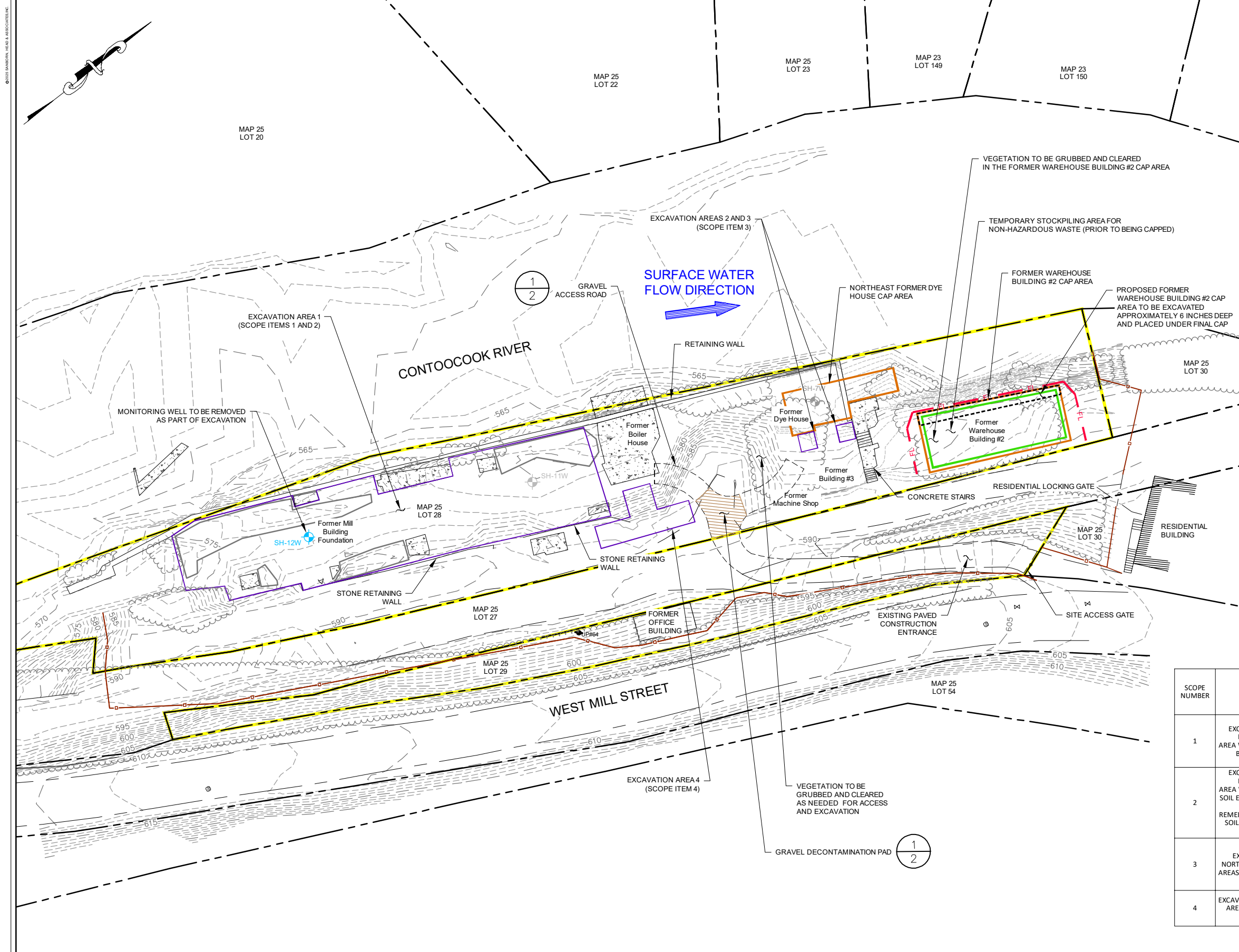

- NOTES:**
- SEE SHEET 1 AND 2 FOR ADDITIONAL NOTES AND LEGEND.
 - SEE SECTION 02 61 13 - EXCAVATION AND HANDLING OF CONTAMINATED MATERIALS AND SECTION 31 20 00 - EARTH MOVING FOR ADDITIONAL DETAILS REGARDING SOIL/ EXCAVATION MANAGEMENT.
 - IF SOIL TO BE EXCAVATED IS DEEPER THAN 3 FEET BASED ON FIELD OBSERVATIONS THEN THE EXCAVATION SIDE SLOPES SHALL BE SLOPED NO STEEPER THAN 2 HORIZONTAL : 1 VERTICAL, SO AS TO HAVE MORE THAN A 3 FOOT VERTICAL CUT, WITH THE TOE OF THE EXCAVATION BEING THE LIMIT OF THE SOIL CONTAMINATION.
 - ORANGE CONSTRUCTION FENCE SHALL BE INSTALLED AT THE END OF THE WORK DAY AROUND ANY EXCAVATION THAT IS DEEPER THAN 3 FEET.
 - EXTENT OF PROPOSED SOIL CAPS MAY BE ADJUSTED IN THE FIELD BASED ON SITE CONDITIONS AND/OR ACCESS LIMITATIONS.
 - THE EXTENT OF THE PROPOSED EXCAVATION AREAS, CAPPING AREAS, AND PROPERTY BOUNDARIES WILL BE CONFIRMED BY THE CONTRACTOR UTILIZING A LICENSED SURVEY PRIOR TO CONSTRUCTION.

- LEGEND:**
- PROPOSED CAP LIMIT
 - - - - - PROPOSED FORMER WAREHOUSE BUILDING #2 CAP AREA TO BE EXCAVATED APPROXIMATELY 6 INCHES DEEP AND PLACED UNDER FINAL CAP
 - EDGE OF PAVEMENT
 - - - - - PROPOSED EDGE OF GRAVEL ACCESS ROAD
 - FL - FL - FL - PROPOSED FILTER LOG
 - APPROX. EXCAVATION AREA TO BE DISPOSED OFF-SITE
 - TEMPORARY STOCKPILING AREA FOR NON-HAZARDOUS WASTE (PRIOR TO BEING CAPPED)

SCOPE NUMBER	SCOPE ITEM	ESTIMATED EXCAVATION THICKNESS (FT)	ESTIMATED VOLUME OF SOIL (CY UNLESS OTHERWISE SPECIFIED)	EXCAVATED SOIL DESTINATION
1	EXCAVATION AREA 1 - FORMER MILL BUILDING FOUNDATION AREA. AREA WHERE GRANULAR FILL WAS PLACED BY USEPA REMOVAL PROGRAM.	1-4 (AVERAGE APPROXIMATELY 1.3)	430	TO BE USED FOR THE FORMER WAREHOUSE BUILDING #2 SOIL CAP AND BACKFILL FOR EXCAVATION AREAS 2 & 3; REMAINING SOILS OFF-SITE
2	EXCAVATION AREA 1 - FORMER MILL BUILDING FOUNDATION AREA. AREA WHERE SOIL BENEATH USEPA COVER SOIL EXHIBITED LIMITED EXCEEDANCES OF PAHs ABOVE THE NHDES SOIL REMEDIATION STANDARDS (SRS) BENEATH SOIL CAP PLACED BY USEPA REMOVALS (SCOPE ITEM 1).	0.5-4 (AVERAGE APPROXIMATELY 2.5)	830	OFF-SITE DISPOSAL
3	EXCAVATION AREAS 2 & 3 - AREAS NORTHEAST OF THE FORMER DYE HOUSE AREAS WHERE LEAD AND PAHs EXCEED SRS	0.5	10	OFF-SITE DISPOSAL
4	EXCAVATION AREA 4 - NEW EMBANKMENT AREA WITH LIMITED EXCEEDANCES OF LEAD ABOVE THE SRS	2	60	OFF-SITE DISPOSAL

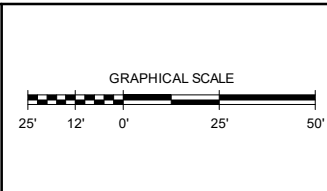

NO.	DATE	DESCRIPTION	BY

DRAWN BY: B. DAILEY
 DESIGNED BY: B. DAILEY / C. VIGNOLA
 REVIEWED BY: H. CAPROOD
 PROJECT MGR: H. CAPROOD
 PIC: J. SANBORN
 DATE: DECEMBER 2025

CONSTRUCTION DESIGN DRAWINGS
FORMER WOODS WOOLEN MILL
 HILLSBOROUGH, NEW HAMPSHIRE
PROPOSED EXCAVATION PLAN

PROJECT NUMBER:
4088.012
 SHEET NUMBER:
3 OF 5

0315 SANBORN HEAD & ASSOCIATES INC. MAJES FILE: P:\WORK\4088.012\Drawings\4088.012\4088.012.dwg LAYOUT: 8/20/2025 10:45:53 AM

GENERAL NOTES:

1. PERIMETER CONTROLS SHALL BE INSTALLED PRIOR TO EARTH MOVING OPERATIONS.
2. THE SMALLEST PRACTICAL AREA SHALL BE DISTURBED DURING CONSTRUCTION, BUT IN NO CASE SHALL EXCEED 100,000 SQUARE FEET AT ANY ONE TIME BEFORE DISTURBED AREAS ARE STABILIZED. THE TERM "STABLE" IS DEFINED AS MEETING ONE OF THE FOLLOWING CRITERIA:
 - A. BASE COURSE GRAVELS HAVE BEEN INSTALLED IN AREAS TO BE PAVED;
 - B. A MINIMUM OF 85 PERCENT VEGETATED GROWTH HAS BEEN ESTABLISHED;
 - C. A MINIMUM THICKNESS OF 3 INCHES OF NON-EROSIVE MATERIAL SUCH AS STONE IS INSTALLED; OR
 - D. EROSION CONTROL BLANKETS ARE PROPERLY INSTALLED.
3. APPLY SEED, LIME, FERTILIZER, AND CLEAN STRAW MULCH TO DISTURBED AREAS AND THE SOIL CAP, WITHIN SEVEN DAYS OF ACHIEVING FINAL GRADE. CLEAN STRAW MULCH SHALL BE APPLIED AT THE RATE OF 1.5 TO 2 TONS PER ACRE.
4. FILTER LOGS SHALL BE INSTALLED DOWNSLOPE OF EXCAVATION AREAS 1,2,3,4, AND 5. FILTER LOGS SHALL BE INSTALLED ALONG THE CONTOUR AND TOED UPSLOPE. FILTER LOGS ARE TO BE MAINTAINED AND CLEANED UNTIL VEGETATIVE COVER IS ESTABLISHED.
5. ALL EROSION CONTROLS, SUCH AS FILTER LOGS, SHALL BE INSPECTED WEEKLY DURING THE LIFE OF THE PROJECT AND AFTER EACH STORM EVENT THAT PRODUCES 0.25 INCHES OF RAINFALL. ALL DAMAGED FILTER LOGS SHALL BE REPAIRED PROMPTLY.
6. REMOVE SEDIMENT BUILD UP FROM BEHIND EROSION AND SEDIMENT CONTROL DEVICES. MAINTAIN TEMPORARY EROSION AND SEDIMENT CONTROL DEVICES UNTIL FULL ESTABLISHMENT OF PERMANENT GROUND COVER.
7. ALL DISTURBED AREAS SHALL BE TEMPORARILY STABILIZED AS SOON AS PRACTICABLE BUT NO LATER THAN 45 DAYS OF INITIAL DISTURBANCE.
8. PERMANENT STABILIZATION OF DISTURBED SOIL SHOULD OCCUR AS SOON AS POSSIBLE BUT NO LATER THAN 3 DAYS FOLLOWING FINAL GRADING (TOPSOIL).
9. FUGITIVE DUST TO BE CONTROLLED IN ACCORDANCE WITH ENV-A 1000.

WINTER NOTES:

1. ALL PROPOSED VEGETATED AREAS THAT DO NOT EXHIBIT A MINIMUM OF 85% VEGETATIVE GROWTH BY OCTOBER 15TH, OR ARE DISTURBED AFTER OCTOBER 15TH, SHALL BE STABILIZED BY SEEDING AND PLACING 3 TO 4 TONS OF MULCH PER ACRE, SECURED WITH ANCHORED NETTING. THE INSTALLATION OF MULCH AND NETTING SHALL NOT OCCUR OVER ACCUMULATED SNOW OR ON FROZEN GROUND AND SHALL BE COMPLETED IN ADVANCE OF THAW OR SPRING MELT EVENTS.

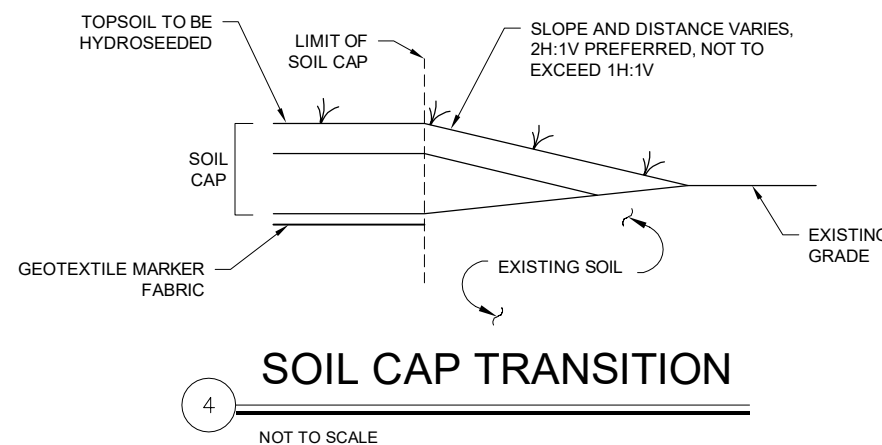
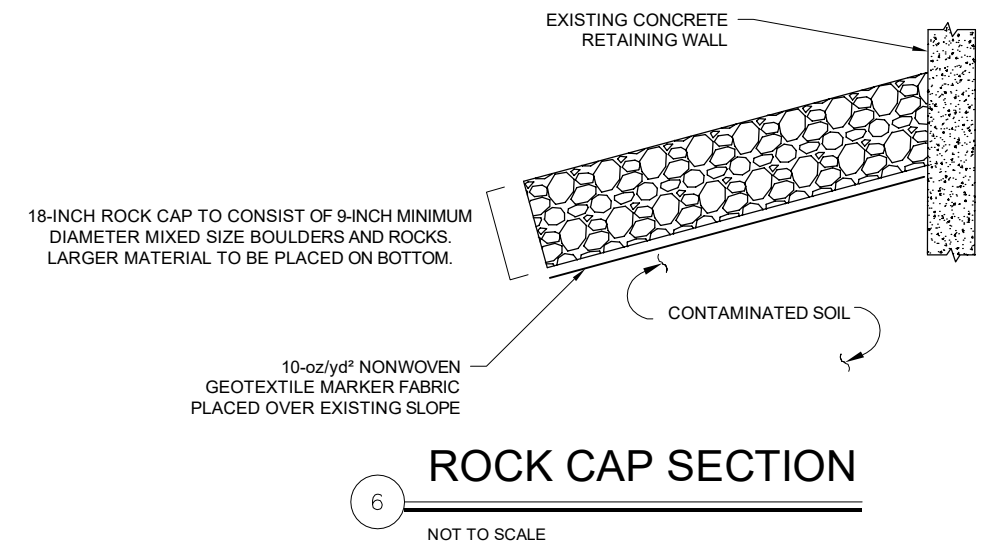
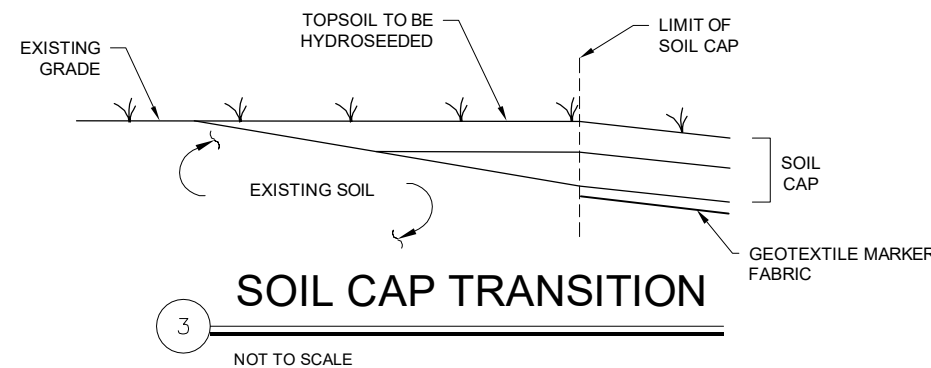
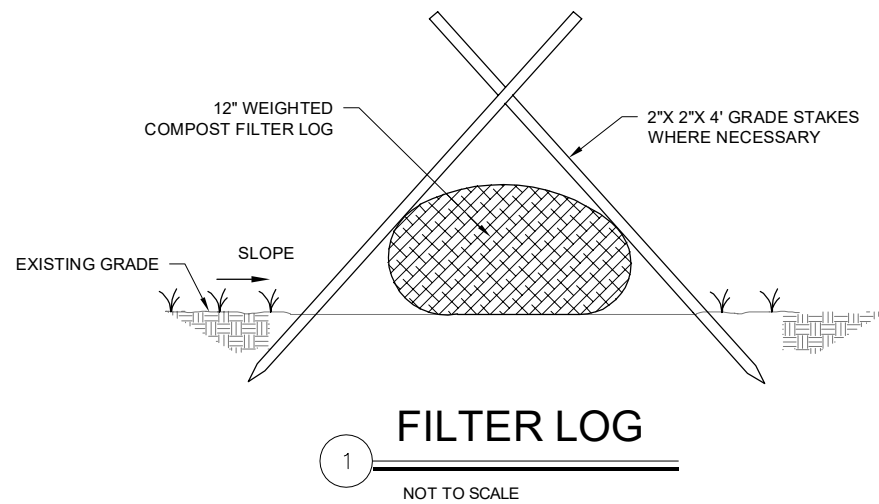
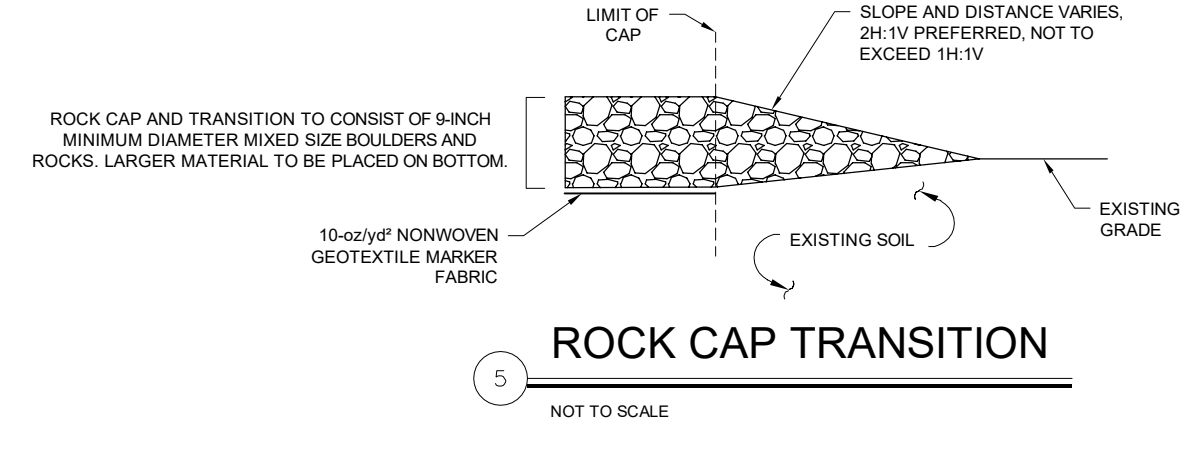
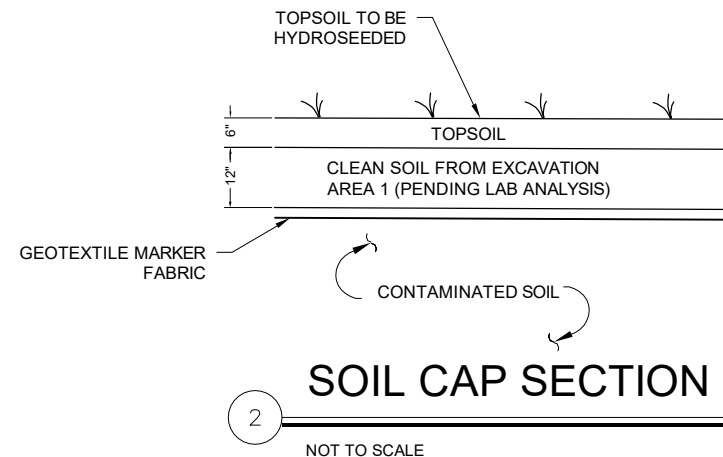

NO.	DATE	DESCRIPTION	BY

DRAWN BY: B. DAILEY
 DESIGNED BY: B. DAILEY
 REVIEWED BY: H. CAPROOD
 PROJECT MGR: H. CAPROOD
 PIC: J. SANBORN
 DATE: DECEMBER 2025

CONSTRUCTION DESIGN DRAWINGS
FORMER WOODS WOOLEN MILL
 HILLSBOROUGH, NEW HAMPSHIRE
**SOIL CAP TRANSITION AND EROSION
 AND SEDIMENT CONTROL DETAILS**

PROJECT NUMBER:
 4088.012
 SHEET NUMBER:
 5 OF 5

Technical Specifications

**SECTION 00 01 10
TABLE OF CONTENTS**

SPECIFICATIONS*

DIVISION 01 – GENERAL REQUIREMENTS

Section 01 11 00 – Summary of Work

Section 01 22 00 – Unit Prices

Section 01 31 00 – Project Management and Coordination

Section 01 33 00 – Submittal Procedures

Section 01 35 29.13 – Health, Safety, and Emergency Response Procedures for Contaminated Sites

Section 01 41 00 – Regulatory Requirements

Section 01 42 00 – References

Section 01 45 00 – Quality Control

Section 01 50 00 – Temporary Facilities and Controls

Section 01 57 13 – Temporary Erosion and Sediment Control

Section 01 57 26 – Site Watering for Dust Control

Section 01 70 00 – Execution and Closeout Requirements

DIVISION 02 – EXISTING CONDITIONS

Section 02 21 00 – Surveys

Section 02 61 13 – Excavation and Handling of Contaminated Materials

DIVISION 31 – EARTH WORK

Section 31 11 00 – Clearing and Grubbing

Section 31 20 00 – Earth Moving

Section 31 23 19 – Dewatering

Section 31 32 00 – Soil Stabilization

DIVISION 32 – EXTERIOR IMPROVEMENTS

Section 32 32 00 – Retaining Walls

Section 32 91 19.13 – Topsoil Placement and Grading

Section 32 92 19.16 – Hydraulic Seeding

Section 32 93 00 – Plants

*Sections shown above in *italics*, as well as any portions within Sanborn Head's specifications that are in *italics*, were prepared by the Hydraulic Engineer (Streamworks, PLLC) for floodplain restoration work. That work is covered by the Restoration Contract being led by Streamworks PLLC and is separate from the Remedial Contract with Sanborn Head.

Division 01

General Requirements

SECTION 01 11 00 – SUMMARY OF WORK

PART 1 - GENERAL

1.01 SUMMARY

- A. This section summarizes the Work to be performed at the Former Woods Woolen Mill site in Hillsborough, New Hampshire (site). This specification section is not all-inclusive and is intended to summarize the key aspects of the Work. The Contractor shall be entirely responsible for performing all Work described in these Contract Documents, whether or not it is specifically or fully described in this specification section.
- B. Portions of this specification shown in *italics* were prepared by the Hydraulic Engineer (Streamworks, PLLC) for floodplain restoration work. That work is covered by the Restoration Contract being led by Streamworks PLLC and is separate from the Remedial Contract with Sanborn Head.

1.02 RELATED SECTIONS

- A. All Drawings and Technical Specifications are related to this Section.

1.03 REFERENCES

- A. Refer to Section 01 41 00 – Regulatory Requirements.

1.04 DEFINITIONS

- A. Refer to Section 01 42 00 – References.

1.05 SUBMITTALS

- A. Refer to Section 01 33 00 - Submittal Procedures

1.06 QUALITY ASSURANCE

- A. Not used.

1.07 SUMMARY OF MAJOR WORK ITEMS

- A. Contractor shall furnish all material, labor, equipment, supervision, coordination, and incidentals required to perform the Work under the contract for the Former Woods Woolen Mill Project (project).
- B. The Contractor shall abide by any restrictions or guidelines for the abutting property's easement of using Lot 27 as an egress.
- C. Contractor shall take care not to spill or inadvertently spread contaminated soil during any activity during construction that involves loading, unloading, and transporting non-hazardous or hazardous soil on-site.
- D. The Contractor shall assist the Engineer with confirmatory soil sample collection from the extent of each excavation, where necessary as deemed by the Engineer.
- E. Major work items to be performed by Contractor in accordance with these Contract Documents shall include, but not be limited to, the following items:

SECTION 01 11 00 – SUMMARY OF WORK

1. Obtain any applicable permits including coverage under the USEPA National Pollutant Discharge Elimination System (NPDES) Construction General Permit (CGP) for Stormwater Discharges from Construction Sites, including submittal of the Notice of Intent (NOI), the applicable requirements and implementation of the site-specific Stormwater Pollution Prevention Plan (SWPPP) prepared by the Engineer, and implementation and maintenance of applicable erosion and sediment controls.
2. Mobilize personnel, equipment, and temporary facilities to the project location at 23-25 West Mill Street in Hillsborough, New Hampshire.
3. Establish horizontal and vertical survey control, including marking out proposed excavation and cap areas, and establish site control through the existing fence and locking gate or construction of a temporary fence and locking gate in accordance with Section 01 50 00 – Temporary Facilities and Controls.
4. Install and maintain construction of temporary erosion and sediment control features in accordance with Section 01 57 13 – Temporary Erosion and Sediment Control. Contractor shall take care to minimize the disturbance of on-site soil and proposed excavation and cap areas during installation and maintenance temporary erosion and sediment control features.
5. Perform clearing and grubbing including invasives removal in areas of the site necessary to complete the Work as outlined on the Drawings. Contractor shall take care to minimize the disturbance of on-site soil, and proposed excavation and cap areas.
6. Construct a gravel access road from the existing paved access road down to the Former Dye House Cap Area and to proposed excavation areas with materials that meet the Specifications as noted in Section 31 20 00 – Earth Moving, and as outlined on the Drawings. Gravel shall be placed in any areas Contractor will need to drive or walk over to provide a clean working surface and limit potential for vehicles and personnel to contact contaminated material. Contractor shall also construct a decontamination pad to wash equipment and vehicles that may come into contact with contaminated materials present within the proposed excavation and capping areas. Contractor shall construct the decontamination pad using materials approved by the Engineer
7. Excavate and direct-load contaminated soils from Excavation Area 4, as designated on the Drawings, for off-site disposal based on the results of pre-characterization soil sampling and analysis conducted by the Engineer. Contaminated soil will only be excavated to the subgrade elevation required for the floodplain restoration work.
8. Excavate and direct-load contaminated soils from Excavation Areas 2 and 3, as designated on the Drawings, for off-site disposal. The Engineer will collect confirmatory soil samples from the excavations for PAH analysis.
9. Pending the results of the laboratory analysis for the confirmatory soil samples collected from Excavation Area 4, as instructed by the Engineer, the Contractor may use the remaining soil within this embankment area to extend the access road down into Excavation Area 1.
10. Contractor shall excavate, transport, and use the existing cover soil to construct the soil caps in the Former Warehouse #2 and portions of the Northeast Former Dye House Cap Areas, pursuant to the Specifications and Drawings. Soil located along the western edge of the Former Warehouse #2 shall be pulled back in accordance with the Drawings prior to placement of capping material for grading purposes.

SECTION 01 11 00 – SUMMARY OF WORK

11. Contractor shall construct a rock cap in accordance with the Drawings in the northern portion of the Northeast Former Dye House Cap Area. Rock shall be 9-inch minimum and may be sourced from on-site materials, if encountered. If 9-in minimum rock is not identified, Contractor shall furnish rock material that abides by the Specifications noted in Section 31 20 00 – Earthwork and from a facility approved by the Engineer.
 12. Place topsoil and hydroseed the Former Warehouse #2 Cap Area in accordance with the Sections 32 91 19.13 – Topsoil Placement and Grading and 32 92 19.16 – Hydraulic Seeding.
 13. Backfill and compact Granular Fill in Excavation Areas 2 and 3.
 14. Excavate and direct-load any remaining contaminated soil from Excavation Area 1 for off-site disposal.
 15. Remove existing monitoring well SH-12W within Excavation Area 1 for off-site disposal as part of excavation activities.
 16. Site cleanup, including removal of erosion and sediment controls and temporary construction fence (if constructed).
 17. Place topsoil, seed, and mulch in areas disturbed by construction beyond the capped areas in accordance with the Sections 32 91 19.13 – Topsoil Placement and Grading, 32 92 19.16 – Hydraulic Seeding.
 18. Demobilize.
- F. All Work summarized in this section is more fully indicated, shown, and described in the Specifications, Drawings, and Contract Documents.
- G. *Work specific to Restoration efforts shall be supplementary to, but separate from, Remediation efforts described above. At times, the work shall be overlapping both in location and/or by task. In general, Restoration involves excavation of non-contaminated materials within the restoration limits, backfilling of the main floodplain, work on the Riverside and Upland retaining walls, final grading and soil stabilization, seeding and planting, and demobilization/cleanup. Work specific to Restoration efforts shall include:*
1. *Excavation of non-contaminated materials remaining within the restoration limits, primarily including bedrock, large rock rubble, and concrete (e.g., former Boiler House foundation slab). All non-contaminated materials may be disposed of in accordance with #2 below, and following approval from the Hydraulic Engineer.*
 2. *Disposal of non-contaminated materials which cannot be reused on-site at any pre-approved (by the Hydraulic Engineer) location which accepts materials excavated.*
 3. *Erosion and sediment control conforming to Section 01 57 13 – Temporary Erosion and Sediment Control and, if necessary, dewatering at the southern project end where a net fill will be placed in accordance with Section 31 23 19 – Dewatering.*
 4. *Backfilling and temporary grading of the floodplain restoration area where contaminated materials have been removed or capped to limit the exposure of potentially-contaminated material, adhering to specifications in Section 31 20 00 – Earth Moving. This will be concurrent with the installation of a temporary, removable stone path along the riverside retaining wall.*
 5. *Work done to remove/restore/rebuild both the Riverside and Upland retaining walls as outlined in Section 32 32 00 – Retaining Walls and in the Drawings.*

SECTION 01 11 00 – SUMMARY OF WORK

6. *Staging and stockpiling of new and reused materials onsite as outlined in these specifications.*
7. *Planting and seeding of the restored floodplain and all disturbed lands, as outlined in the Drawings and in Sections 32 92 19.16 – Hydraulic Seeding, 32 93 00 – Plants, and 31 32 00 – Soil Stabilization.*
8. *Marked-up, redlined plans denoting changes to the design (if any), and an as-built topographic survey of all disturbed lands and locations of all relevant site features (retaining walls, habitat features, monuments or benchmarks, fencing, vegetation limits and types, etc.).*
9. *Execute final closeout and demobilize.*

1.08 WORK SCHEDULE

- A. The Work shall be completed in general order as defined in Section 1.07. Certain work items may be concurrent.
- B. In general, Remediation efforts will precede Restoration efforts.

1.09 SPECIAL REQUIREMENTS

- A. Contractor's staging area shall be located within an area designated by the Engineer. Stockpiles of material shall only be located in designated areas or areas approved by the Engineer. No materials may be staged or stockpiled on parcel Map 25 Lot 27.
- B. Contractor is responsible for protecting the project site from stormwater run-on from adjacent areas and repairing erosion and sedimentation within the project site.
- C. Contractor is responsible for protecting areas downgradient of the area under construction from erosion and sedimentation caused by stormwater runoff from the area under construction.
- D. Contractor is responsible for protecting existing structures including, but not limited to, fire hydrants, utility poles and lights, residential fencing, retaining walls, foundations, etc. Any damage shall be repaired as directed by Owner at no additional cost.
- E. The designated disposal facility(ies) shall be approved, permitted disposal facility(ies) determined by Contractor and approved by Engineer and Owner. Contractor shall coordinate with Engineer to secure written approval from the designated disposal facility(ies) for disposal of lead, arsenic, antimony, chromium, and polycyclic aromatic hydrocarbon (PAH)-containing material as needed. Engineer will assist Contractor in securing disposal facility approval by providing laboratory analytical data for soil samples collected by Engineer.
- F. The Contractor shall prepare all waste manifest forms required under federal, state, and local law. When found to be satisfactory, the Owner or its representative will sign waste manifests as the generator.

1.10 GENERAL QUALITY CONTROL

- A. Contractor shall maintain quality control over the suppliers, manufacturers, products, services, site conditions, and workmanship to produce work of specified quality.
- B. Contractor shall comply with industry standards except when more restrictive tolerances or specified requirements indicate more rigid standards or more precise workmanship.
- C. See Section 01 45 00 – Quality Control and individual sections for appropriate standards.

SECTION 01 11 00 – SUMMARY OF WORK

PART 2 - PRODUCTS

2.01 MATERIALS

- A. Not used.

PART 3 - EXECUTION

3.01 CONTRACTOR USE OF SITE AND PREMISES

- A. No work shall be performed outside the established limit of disturbance as can be inferred from the Drawings without prior approval from Owner.
- B. Contractor shall confine their materials and their storage, and the operation of their work to limits indicated by laws, ordinances, permits, directions of Owner and Engineer, and as shown on the Drawings or otherwise indicated in the Contract Documents, and will not unreasonably encumber the premises with such materials, but shall store them in orderly fashion so that they will not interfere with the Work.
- C. The Contractor may stockpile clean materials on-site prior to placement; however, the Contractor is solely responsible for grading and sealing earth material stockpile surfaces and installing and maintaining the necessary temporary erosion control measures.
- D. All materials shall be loaded and trucked to the project site by the Contractor for use during the construction unless otherwise specified. Any on-site areas disturbed by the Contractor must be returned to their original condition. Dust control shall be provided in accordance with the Specifications.

3.02 OBSERVATION AND TESTING FOR QUALITY CONTROL

- A. This Section does not address sampling and testing for laboratory analysis of material for confirmatory or disposal purposes. Confirmatory and disposal analysis will be completed by the Engineer if needed, as discussed in Section 02 61 13, Excavation and Handling of Contaminated Material.
- B. Owner will employ and pay for the services of an Engineering Firm(s) to administer the Construction Agreement and perform construction observation. These services will be performed in accordance with the requirements of governing authorities, to establish whether the work is in accordance with the Drawings and Specifications.
- C. Contractor shall cooperate with Engineer, and furnish tools, equipment, samples of materials, and assistance as requested.
- D. The work shall be subject to the observation of Owner and/or Engineer. Observation or non-observation by Owner and/or Engineer shall not relieve Contractor from his contractual obligation to furnish work and material as required, and properly complete the work in accordance with the Drawings and Specifications. If Owner or Engineer considers that the work is not properly accomplished, they may condemn or reject all or any part of the work and any materials or equipment incorporated in it. If any material, equipment, or work is condemned or rejected by Owner or Engineer, Contractor shall bear all expenses for removal and proper replacement of such material, equipment, or work replacing any work done by others which is adversely affected by removal and proper replacement of improper work done by Contractor.

SECTION 01 11 00 – SUMMARY OF WORK

3.03 MANUFACTURER'S INSTRUCTIONS AND CERTIFICATES

- A. Contractor shall comply with manufacturers' instructions in full detail, including each step in sequence. If instructions conflict with any drawing or specification, then the Contractor should request clarification from Engineer and/or Owner before proceeding.
- B. Contractor shall submit the manufacturer's certificate that products meet or exceed the specified requirements.

3.04 SUBSTANDARD WORK OR MATERIALS

- A. Any defective or substandard work or materials furnished by Contractor that is discovered before the final acceptance of the Work, as established by the Certificate of Substantial Completion, or during the subsequent guarantee period, shall be removed immediately even though it had been overlooked by Engineer and recommended for payment. Any equipment or materials condemned or rejected by Engineer shall be tagged as such and shall be immediately removed from the site. Satisfactory work or materials shall be substituted for that rejected.
- B. Engineer may order tests on substandard or damaged work, equipment, or materials to determine the required functional capability for possible acceptance, if there is no other reason for rejection. The cost of such tests shall be borne by Contractor and the nature, extent, and supervision of the tests will be as determined by Engineer. If the results of the tests indicate that the required functional capability of the work, equipment, or material was not impaired, consistent with the final general appearance of same, the work, equipment, or materials may be deemed acceptable. If the results of such tests reveal that the required functional capability of the questionable work or materials was impaired, then such work or materials shall be deemed substandard and shall be replaced. Contractor may elect to replace the substandard work or material instead of performing the tests.

END OF SECTION

SECTION 01 22 00 – UNIT PRICES

PART 1 - GENERAL

1.01 SUMMARY

- A. Section includes requirements for measurement of quantities and basis of payment.
- B. Related Sections
 - 1. Section 01 11 00 – Summary of Work

1.02 REFERENCES

- A. Refer to Section 01 41 00 – Regulatory Requirements.

1.03 DEFINITIONS

- A. Refer to Section 01 42 00 – References.

1.04 SUBMITTALS

- A. Refer to Section 01 33 00 – Submittal Procedures

1.05 QUALITY ASSURANCE

- A. Not used.

PART 2 - PRODUCTS

Not Used.

PART 3 - EXECUTION

- A. Measurement of Contract Items
 - 1. Measurements shall not be obtained for lump sum items.
 - 2. All payment items bid on a lineal foot basis shall be measured along the centerline of such feature.
 - 3. All payment items bid on an areal acreage or square footage basis shall be measured by the horizontal projection of the Work.
- B. Basis of Payment
 - 1. For lump sum payment items, payments to Contractor will be based upon Contractor's estimate of percentage completion of the lump sum tasks unless stated otherwise in the payment item definitions. The estimate shall be based on approximated quantities of Work completed in accordance with the Design Drawings and Technical Specifications, and shall be reviewed and approved by Engineer.
 - 2. The basis of payment shall be on a per unit basis as outlined in the Bid Item Definitions. Additions or deletions for non-lump sum items will be calculated from the aforementioned survey and respective unit price.
 - 3. Any requests for addition or deletion of work not defined in the contract documents, which may result in an addition or deletion to the contract price, must have prior approval from Owner (or their authorized representative) as evidenced by a fully completed Change Order signed by both parties.

END OF SECTION

SECTION 01 31 00 – PROJECT MANAGEMENT AND COORDINATION

PART 1 - GENERAL

1.01 SUMMARY

- A. Section includes requirements for administration and supervision necessary for coordination of construction operations including, but not limited to, the following:
 - 1. General project coordination procedures.
 - 2. Requests for Information (RFIs)
 - 3. Project meetings.
 - 4. Project reports.
 - 5. Project schedule.

1.02 RELATED SECTIONS

- A. Section 01 11 00 – Summary of Work
- B. Section 01 33 00 - Submittal Procedures
- C. Section 01 22 00 – Unit Prices
- D. Section 01 70 00 – Execution and Closeout Requirements

1.03 REFERENCES

- A. Refer to Section 01 41 00 – Regulatory Requirements.

1.04 DEFINITIONS

- A. Refer to Section 01 42 00 – References.

1.05 SUBMITTALS

- A. Comply with the requirements and procedures of Section 01 33 00 - Submittal Procedures.
- B. RFI Log: Prepare, maintain, and submit a tabular log of RFIs.
- C. Project Schedule: Prepare, maintain, and distribute the Project Schedule and periodic updates to the schedule.

1.06 QUALITY ASSURANCE

- A. Not Used.

1.07 GENERAL COORDINATION

- A. Coordinate construction operations to ensure efficient and orderly advancement of each phase of Work, including inter-dependencies and sequencing relationships between different operations and phases.
 - 1. Schedule construction operations in a sequence that will obtain the best results where advancement of each phase of Work depends on other operations, before or after its own advancement.

SECTION 01 31 00 – PROJECT MANAGEMENT AND COORDINATION

2. Coordinate different components to ensure maximum performance and accessibility.
 3. Make provisions to accommodate items scheduled for later sequencing.
- B. Where necessary, prepare memoranda for distribution to each party involved (e.g., Owner, Engineer, subcontractors, etc.), outlining special procedures required for coordination. Include such items as required notices, reports, and attendance at meetings.
- C. Administrative Procedures: Coordinate scheduling and timing of required administrative procedures with other construction activities to avoid conflicts and to ensure orderly advancement of the Work. Such administrative procedures include, but are not limited to, the following:
1. Preparation of Contractor's construction schedule
 2. Preparation of a Schedule of Values
 3. Installation and removal of temporary facilities and controls
 4. Delivery and processing of submittals
 5. Progress meetings and conferences
 6. Closeout activities
 7. As-builts

1.08 REQUESTS FOR INFORMATION

- A. General: Upon discovery of the need for additional information or interpretation of the Contract Documents, Contractor shall prepare and submit an RFI. Coordinate and submit RFIs in a prompt manner to avoid delays in Contractor's work and work of subcontractors. Delay of preparation and submission of an RFI by Contractor shall not constitute grounds for a time extension under the Contract Documents.
- B. Content: Each RFI shall at minimum including the following:
1. Project Name
 2. Date
 3. Name of Contractor
 4. Name of Engineer
 5. RFI Number (Numbered sequentially)
 6. RFI Subject
 7. Reference to applicable Technical Specification(s)
 8. Reference to applicable Drawing Sheet(s) and Detail(s)
 9. Field Dimensions and Conditions, as applicable
 10. Contractor's proposed resolution. If the proposed resolution impacts the schedule (time) or cost of the Work, Contractor shall state such impacts in the RFI.
 11. Contractor's Signature

SECTION 01 31 00 – PROJECT MANAGEMENT AND COORDINATION

12. Attachments, as applicable, for Owner and Engineer to interpret the RFI; including, but not limited to, the following: sketches, descriptions, measurements, photos, Product Data, etc.
- C. Format: Each RFI shall be submitted on an acceptable form, as listed below.
 1. American Institute of Architects (AIA) Document G716
 2. Construction Specifications Institute (CSI) Form 13.2A
 3. Contractor generated form that substantially similar to 1. or 2. Listed above.
- D. Submission: Each RFI, inclusive of all attachments, shall be submitted electronically to Engineer. If an attachment cannot be submitted electronically because of its nature (i.e., physical material sample), it should be delivered to Engineer promptly. The RFI will not be considered complete until all attachments are delivered.
- E. Engineer's Review and Action: Upon receipt of the RFI, Engineer will review and provide response within 10 working days. RFIs received after 1:00 PM will be considered received the following working day. Engineer's action may include a request for additional information, in which case the time for response will date from the time of receipt of additional information.
- F. Contractor's Response: On receipt of Engineer's action, update RFI Log and distribute the RFI response to affected parties. If Contractor disagrees with response, Engineer shall be notified within five working days. Notification shall include rational and supporting information to substantiate any claims made.

1.09 PRECONSTRUCTION MEETING

- A. The Contractor shall not commence work until after a preconstruction meeting has been held at the Project site with representatives of the Contractor, the Engineer, and the Owner. The preconstruction conference will be arranged by the Engineer and is intended to establish lines of communication between the parties involved. The time and place of the preconstruction conference will be provided with the Notice of Award.

1.10 PROGRESS MEETINGS

- A. The Contractor will arrange for weekly progress meetings, as needed. The meetings will be held to review the work progress, to discuss upcoming work, to make necessary adjustments to schedules, to discuss submittals, changes, substitutions, and other items affecting the Project. The Engineer and as needed, the Owner, will preside at progress meetings either in-person or virtually.
- B. Attendance at the progress meetings will include the Contractor and the Engineer, and as needed the Owner, major subcontractors, and suppliers as appropriate to discuss agenda topics for each meeting.

1.11 UNSCHEDULED MEETINGS

- A. Contractor shall attend unscheduled meetings as requested by Engineer or Owner.

1.12 JOB SITE ADMINISTRATION

- A. The Contractor shall supervise, inspect and direct the Work competently and efficiently, devoting such attention thereto and applying such skills and expertise as may be necessary to perform the Work in accordance with the Contract Documents. The Contractor shall be solely responsible for the health and safety aspects of the work and the means, methods, techniques, sequences and procedures of construction. The Contractor shall be responsible for the completed work complying accurately with the Contract Documents.

SECTION 01 31 00 – PROJECT MANAGEMENT AND COORDINATION

- B. The Contractor shall provide a competent and authorized Superintendent at the Project site during all working hours who shall act as the agent of the Contractor.
- C. The Superintendent shall be capable of reading and thoroughly understanding the Contract Drawings and Specifications, with full authority to fulfill the Contractor’s duties and responsibilities required to successfully perform the Work. If in the opinion of the Owner, the Superintendent or any of their successors prove incompetent, not conscientious, or not industrious, then the Contractor shall replace them upon written request by the Owner.
- D. The Contractor shall only employ competent individuals on the job. Whenever the Owner or Engineer of Owner notifies the Contractor in writing that, in its opinion, any individual on the job, whether employed by the Contractor or any of the subcontractors, is not adhering to the Safety and Health Rules or imperils the safety of others, or is incompetent, unfaithful, disorderly, or otherwise unsatisfactory, such individual shall be discharged from the Work and shall not be employed on the Work, except with the written consent of the Owner or Engineer of Owner.
- E. The Engineer’s presence does not include supervision or direction of the actual work by the Contractor, his employees, or agents. Neither the presence of the Engineer nor any observations and testing performed by him shall excuse the Contractor from defects discovered in his work.

1.13 SAFETY MEETINGS

- A. Refer to Section 01 35 29.13 – Health, Safety, and Emergency Response Procedures for Contaminated Sites for the requirements related to Safety Meetings.

1.14 PROJECT SCHEDULES

- A. Contractor shall maintain the Project Schedule throughout the duration of the Work.
- B. The Project Schedule shall be periodically updated at the discretion of Engineer.
- C. Refer to Section 01 33 00 - Submittal Procedures for a description of Project Schedule elements.

PART 2 - PRODUCTS

Not Used

PART 3 - Execution

Not Used

END OF SECTION

SECTION 01 33 00 – SUBMITTAL PROCEDURES

PART 1 - GENERAL

1.01 SUMMARY

- A. Where required by these Technical Specifications, Contractor shall submit descriptive information that will enable Engineer to review whether Contractor's proposed materials, equipment, and means and methods are in general conformance with the design concept and in accordance with the Drawings and Technical Specifications. The information submitted may consist of work plans, drawings, specifications, descriptive data, product data or cut sheets, certifications, samples, test results, and other such information as required in these Technical Specifications.
- B. Portions of this specification shown in *italics* were prepared by the Hydraulic Engineer (Streamworks, PLLC) for floodplain restoration work. That work is covered by the Restoration Contract being led by Streamworks PLLC and is separate from the Remedial Contract with Sanborn Head.

1.02 RELATED SECTIONS

- A. All Drawings and Technical Specifications are related to this Section.

1.03 REFERENCES

- A. Refer to Section 01 41 00 – Regulatory Requirements.

1.04 DEFINITIONS

- A. Refer to Section 01 42 00 – References.

1.05 SUBMITTALS

- A. Refer to Table 1 herein for a list of required submittals.
- B. Submittals include, but are not limited to, the following categories:
 - 1. Administrative
 - a. Construction Schedule to be submitted within 14 days of the Notice of Award. The schedule shall be shown as a horizontal bar chart with separate bars for each major Work item and project milestones. The submittal shall be updated every two weeks during the project to reflect the Work completed and any changes in the schedule. Major Work items are anticipated to include at a minimum:
 - 1) Mobilization
 - 2) Establishing Temporary Facilities and Controls
 - 3) Establishing Temporary Erosion and Sediment Controls
 - 4) Clearing and Grubbing including Invasives Removal
 - 5) Construction of Gravel Access Road and Decontamination Pad to access Excavation Areas 2, 3, 4, and 5
 - 6) Excavation and Off-Site Disposal of Excavation Areas 2, 3, 4, and 5
 - 7) Construction of Access Road into Excavation Area 1

SECTION 01 33 00 – SUBMITTAL PROCEDURES

- 8) Excavation of Excavation Area 1, construction of caps, and backfilling of Excavation Areas 3 and 4
 - 9) Off-Site Disposal for Excavation Area 1
 - b. *Construction Schedule relating to Restoration work to be submitted within 14 days of the Notice of Award. The schedule shall be shown as a horizontal bar chart with separate bars for each major Work item and project milestones. The submittal shall be updated every two weeks, if updates are necessary, during the project to reflect the Work completed and any changes in the schedule. Major Work items are anticipated to include at a minimum:*
 - 1) *Excavation and Disposal of Non-Contaminated Materials, primarily concrete, large rock rubble, and bedrock.*
 - 2) *Backfilling and Grading with clean fill.*
 - 3) *Riverside and Upland Retaining Wall Construction including construction of a temporary stone path for access during the Riverside retaining wall work.*
 - 4) *Seeding of all Disturbed Lands, Planting for Floodplain Restoration*
 - 5) *As-Built Survey.*
 - 6) Site Restoration and Demobilization
2. Technical
 - a. Manufacturer's specifications, product data and cut sheets, as required in the Specifications. The Contractor shall clearly mark each copy of the product data sheets to identify applicable products, models, options, and other data.
 3. Contractor Work Plans
 - a. Contractor work plans shall present the Contractor's detailed approach for implementing the Work. Work plans shall include, at a minimum, details related to the following:
 - 1) A narrative of the anticipated activities and potential sequencing as well as the Contractor's normal operating procedures;
 - 2) The task and objectives of operations to complete the Work, and logistics and resources required to achieve those tasks and objectives;
 - 3) Personnel and equipment requirements for implementing the work plan; and
 - 4) Contractor work plans shall demonstrate Contractor's understanding and confirmation of project conditions.
 4. Inspections, Monitoring, and Maintenance Data and Reports
 - a. Stormwater, erosion, and sediment control plan and weekly inspection and monitoring data and reports.
 - b. Dust control plan.
 5. Transportation and Waste Profiles (if needed)
 - a. Certified weight tickets;

SECTION 01 33 00 – SUBMITTAL PROCEDURES

- b. Waste profiles; and
- c. Shipping paperwork (e.g., Bills of Lading, Manifest, etc.).

1.06 QUALITY ASSURANCE

- A. Each submittal shall be in the English language.
- B. Contractor shall be responsible for the accuracy and completeness of the information contained in each submittal and shall ensure the material, equipment, and method are accurately described.
- C. Contractor shall verify all features of products to conform with the requirements of the Technical Specifications and Drawings.
- D. Contractor shall ensure there is not conflicts with other submittals and notify Engineer in each case where its submittal may affect the Work.
- E. All submittals must be received and approved or acknowledged, as required, by the Engineer before the Work associated with that submittal can proceed.

1.07 DEVIATIONS

- A. At the time of submission, Contractor shall give notice in writing in the submittal of any deviation from the requirements of the Drawings and Technical Specifications. The deviations shall be clearly indicated or described.
- B. Contractor shall state, in writing, variations of cost occasioned by the deviations and an assumption of the costs of related changes, if the deviation is approved.
- C. Contractor shall state, in writing, variations to the scheduled delivery as a result of the deviations, if the deviation is approved.
- D. Engineer shall have 24 hours to review and approve or reject the requested deviation. Contractor shall not initiate procurement for or implementation of a proposed deviation without receipt of prior written approval from the Owner.

1.08 SUBMITTAL PROCEDURES

- A. All submittals shall be directed to Engineer.
- B. Transmittal of Submittal
 - 1. Submittals shall be provided in electronic format in both Microsoft Office® document format (.docx) and in Portable Document Format (PDF). Engineering Drawings and surveys shall be provided in AutoCAD® format [.dwg (2016 or later)], and as a PDF, with Drawing data (points, surfaces, alignments, etc.) provided in LandXML format (version 1.2). Any references, data, or other supporting Drawing information shall be provided in industry-standard formats (i.e. point files in .csv or .txt formats; spatial information in .shp format) approved by Hydraulic Engineer prior to submittal.
 - 2. Submittals in PDF format shall be property orientated (i.e., text is readable without requiring a page rotation) and main and sub-headings bookmarked.
- C. Submittal Identification

SECTION 01 33 00 – SUBMITTAL PROCEDURES

1. A unique number, sequentially assigned, shall be noted on the transmittal form accompanying each item submitted.
 2. Each submittal shall be clearly titled as indicated in Table 1 and include:
 - a. Contract title and number;
 - b. Technical Specification Section;
 - c. Date of transmittal; and
 - d. Name of Contractor, subcontractor, supplier, and manufacturer, as appropriate.
 3. Resubmittals shall clearly identify each correction or change made.
- D. Submittal Completeness - Submittals shall clearly identify, as applicable, the following:
1. Products or materials included;
 2. Compliance with the Drawings and Technical Specifications;
 3. Notation of coordinating requirements;
 4. Notation of dimensions;
 5. Compliance with recognized trade association standards;
 6. Compliance with recognized testing agency standards;
 7. Application of testing agency labels and seals; and
 8. Other relevant information to aid Engineer in their review.

1.09 SUBMITTAL REVIEW

- A. Engineer shall reply to Contractor within 7 days of receipt of each submittal and state whether or not Contractor must resubmit.
- B. Engineer will review and take appropriate action on Submittals in accordance with the approved Schedule of Submittals.
- C. Engineer's review shall be limited in scope and for the purpose of checking if the information covered by the submittals are compatible with the design and conform to the information of the Technical Specifications and Drawings.
- D. Engineer's review will not extend to design data reflected in submittals which is peculiarly within the special expertise of Contractor or Contractor's Subcontractors or Suppliers. Review and acknowledgement of a component item will not indicate approval of the assembly in which the item functions.
- E. Engineer's review will not relieve Contractor of responsibility for any deviation from the requirements of the Drawings and Technical Specifications, unless Contractor has in writing called Engineer's attention to such deviation at the time of submission, and Engineer has given written concurrence of the specific deviation. Concurrence by Engineer shall not relieve Contractor from responsibility for errors or omissions in submittals.
- F. Engineer shall return submittals to the Contractor for distribution or resubmission, if required by the Contract Documents.

SECTION 01 33 00 – SUBMITTAL PROCEDURES

1.10 CONSTRUCTION WORK PLAN

- A. Contractor shall prepare a Construction Work Plan that presents the Contractor’s detailed approach for implementing the Work. The Construction Work Plan shall include Construction Sequence and Project Schedule, and the details as described under Section 1.05 B.
- B. The Construction Work Plan shall also include, at minimum, the following subsections as separate submittals.
- C. Health and Safety Plan
 - 1. As required by Section 01 35 29.13 - Health, Safety, and Emergency Response Procedures for Contaminated Sites, and in accordance with 29 CFR 1910.120.
 - 2. At minimum, Contractor’s Site-specific Health and Safety Plan shall include the elements listed in 29 CFR 1910.120(b)(4).
 - 3. The following valid training certificates are required to be appended to the site-specific HASP for each Contractor personnel and subcontractor.
 - a. Initial 40-hour Hazardous Waste operations and emergency response (HAZWOPER) training;
 - b. Current annual eight-hour HAZWOPER refresher training; and
 - c. Eight-hour HAZWOPER supervisor training for personnel designated to perform an on-site HAZWOPER supervisory capacity.
- D. Dust Control Plan
 - 1. Describe means and methods to control dust during construction activities and transport of materials in accordance with 01 50 00 - Temporary Facilities and Controls.
- E. Stormwater, Erosion, and Sediment Control Plan
 - 1. Describes means and method to control stormwater, erosion, and sediment.
 - 2. Describes weekly inspection, monitoring, and maintenance procedures including example inspection form.
 - 3. In accordance with Section 01 50 00 - Temporary Facilities and Controls.

PART 2 - PRODUCTS

Not Used

PART 3 - EXECUTION

Not Used

END OF SECTION

SECTION 01 33 00 – SUBMITTAL PROCEDURES

Section	Section Title	Submittal Title	Deadline
Remediation Submittals (for Sanborn Head)			
01 57 13	Temporary Erosion and Sediment Control	Disposal facility for any accumulated sediment and temporary erosion control structures	With bid
01 70 00	Execution and Closeout Requirements	Waste Profiles (w/Tabulated Data & Laboratory Reports)	Prior to final payment
02 61 13	Excavation and Handling of Contaminated Material	Disposal facility(ies) for Non-Hazardous and Hazardous Waste Soils	With bid
31 11 00	Clearing and Grubbing	Disposal facility(ies) for any stumps, large roots, branches, other wood, brush, weeds, grass, other perishable material, and invasive species (e.g., Japanese Knotweed) resulting from the clearing and grubbing operations	With bid
01 31 00	Project Management and Coordination	Construction Schedule	Within 14 days after Notice of Award and every two weeks for project duration
01 31 00	Project Management and Coordination	Construction Work Plan	Within 28 days after Notice of Award
01 35 29.13	Health, Safety, and Emergency Response Procedures for Contaminated Sites	Health and Safety Plan	Within 28 days after Notice of Award
01 57 13	Temporary Erosion and Sediment Control	Stormwater, Erosion, and Sediment Control Plan	Within 28 days after Notice of Award
01 57 13	Temporary Erosion and Sediment Control	Erosion and Sediment Control - Manufacturer's Product Data	Within 28 days after Notice of Award
01 57 26	Site Watering and Dust Control	Dust Control Plan	Within 28 days after Notice of Award
01 57 13	Temporary Erosion and Sediment Control	NPDES Construction General Permit Notice of Intent	45 days prior to commencing site work

SECTION 01 33 00 – SUBMITTAL PROCEDURES

Section	Section Title	Submittal Title	Deadline
02 61 13	Excavation and Handling of Contaminated Material	Procedure for decontamination of tools and equipment, including decontamination pad construction	14 days prior to the start of any construction activity
02 61 13	Excavation and Handling of Contaminated Material	Methodology for soil tracking	14 days prior to the start of any construction activity
32 20 00	Earth Moving	Locations and methods for on-site temporary stockpiling and soil segregation	14 days prior to the start of any construction activity
01 50 00	Temporary Facilities and Controls	Product Data - contingency temporary construction fence and gates if the existing fencing and gate must be replaced	14 days prior to placement and/or use
31 20 00	Earth Moving	Product Data and Facility of Origin – Geotextile Marker Barrier (For Caps)	14 days prior to placement and/or use
31 20 00	Earth Moving	Product Data and Facility of Origin – Contingency granular fill (including moisture-density and gradation) if exceedances are detected within the clean soils onsite	14 days prior to placement and/or use
31 20 00	Earth Moving	Product Data and Facility of Origin – Crushed Gravel (including moisture-density and gradation) for the access road and decontamination pad	14 days prior to placement and/or use
32 91 19.13	Topsoil Placement and Grading	Product Data and Facility of Origin - Topsoil	14 days prior to placement and/or use
32 92 19.16	Hydraulic Seeding	Product Data and Facility of Origin - Seed, Mulch, and Fertilizer Data	14 days prior to placement and/or use
01 57 13	Temporary Erosion and Sediment Control	SWPPP Inspection Form	Every 7 days following start of construction activity
02 21 00	Surveys	Survey Data	14 days following completion of survey
02 61 13	Excavation and Handling of Contaminated Material	Weight tickets from designated disposal/reclamation facility(ies) documenting tonnage disposed. Payment will not be made for transportation and disposal of materials for which Contractor has not obtained weight tickets	With each applicable Application for Payment

SECTION 01 33 00 – SUBMITTAL PROCEDURES

Section	Section Title	Submittal Title	Deadline
01 70 00	Execution and Closeout Requirements	Certificate of Substantial Completion signed by the Contractor	On or before the Contract Substantial Completion Date
01 70 00	Execution and Closeout Requirements	Certificate of Final Completion signed by the Contractor	On or before the Contract Final Completion Date
01 70 00	Execution and Closeout Requirements	Addenda	Prior to final payment
Restoration Submittals (for Streamworks PLLC)			
01 70 00	Execution and Closeout Requirements	Waste Profiles (w/Tabulated Data & Laboratory Reports)	Prior to final payment
01 31 00	<i>Project Management and Coordination</i>	<i>Construction Schedule</i>	<i>Within 14 days after Notice of Award and every two weeks for project duration</i>
01 31 00	<i>Project Management and Coordination</i>	<i>Construction Work Plan</i>	<i>Within 28 days after Notice of Award</i>
01 57 13	<i>Temporary Erosion and Sediment Control</i>	<i>Stormwater, Erosion, and Sediment Control Plan</i>	<i>Within 28 days after Notice of Award</i>
01 57 13	<i>Temporary Erosion and Sediment Control</i>	<i>Erosion and Sediment Control - Manufacturer's Product Data</i>	<i>Within 28 days after Notice of Award</i>
31 20 00	<i>Earth Moving</i>	<i>Locations and methods for on-site temporary staging/stockpiling</i>	<i>14 days prior to the start of any construction activity</i>
31 20 00	<i>Earth Moving</i>	<i>Product Data and Facility of Origin – clean loam backfill</i>	<i>14 days prior to placement and/or use</i>
31 20 00	<i>Earth Moving</i>	<i>Product Data and Facility of Origin – Crushed Gravel for temporary path during Riverside retaining wall work</i>	<i>14 days prior to placement and/or use</i>
31 23 19	<i>Dewatering</i>	<i>Layout and methods for dewatering</i>	<i>14 days prior to placement and/or use</i>
31 32 00	<i>Soil Stabilization</i>	<i>Product Data – Coir Fabrics (blanket, net, mesh and any fasteners)</i>	<i>14 days prior to placement and/or use</i>

SECTION 01 33 00 – SUBMITTAL PROCEDURES

Section	Section Title	Submittal Title	Deadline
32 32 00	<i>Retaining Walls</i>	<i>Product Data – Mortar (or other material used to reinforce walls)</i>	<i>14 days prior to placement and/or use</i>
32 93 00	<i>Plants</i>	<i>Product Data and Facility of Origin – Trees, Shrubs, Livestakes (includes support materials like stakes, rope, deterrents)</i>	<i>14 days prior to placement and/or use</i>
32 93 00	<i>Plants</i>	<i>Documentation of Successful Installation</i>	<i>Within 7 days after installation (applicable to all plants)</i>
02 21 00	<i>Surveys</i>	<i>As-Built Plans, Drawing Files, and Supporting Files</i>	<i>14 days following the completion of survey though prior to Final Closeout</i>
01 70 00	<i>Execution and Closeout Requirements</i>	<i>Certificate of Substantial Completion signed by the Contractor</i>	<i>On or before the Contract Substantial Completion Date</i>
01 70 00	<i>Execution and Closeout Requirements</i>	<i>Certificate of Final Completion signed by the Contractor</i>	<i>On or before the Contract Final Completion Date</i>

SECTION 01 35 29.13 - HEALTH, SAFETY, AND EMERGENCY RESPONSE PROCEDURES FOR CONTAMINATED SITES

PART 1 - GENERAL

1.01 SUMMARY

- A. The Site is a Town-owned New Hampshire Department of Environmental Services Hazardous Waste Project (NHDES ID: 199909015). Remedial actions are being conducted pursuant to New Hampshire Code of Administrative Rules Chapter Env-Or 600 Contaminated Site Management. Concentrations of polycyclic-aromatic hydrocarbons (PAHs), lead, antimony, chromium, and arsenic have been detected at concentrations exceeding their respective NHDES Soil Remediation Standards (SRS) in soil at the site related to former mill operations and hazardous building materials from former buildings at the Woods Woolen Mill.
- B. This Section specifies the minimum health and safety requirements for the Site. Contractor shall develop and implement a Site-specific Health and Safety Plan (HASP) and shall assume responsibility for the means and methods of safety including general safety oversight authority for the health, safety, and protection of Contractor and subcontractor on-site personnel, visitors, and the general public during the performance of the Work.
- C. Provide facilities, labor, materials, tools, equipment, transportation, and supervision necessary to complete the Work specified in this Section in a safe, diligent, and compliant manner.

1.02 RELATED SECTIONS

- A. Section 01 11 00 – Summary of Work
- B. Section 01 33 00 – Submittal Procedures
- C. Section 01 50 00 – Temporary Facilities and Controls

1.03 REFERENCES

- A. Refer to Section 01 41 00 – Regulatory Requirements.

1.04 DEFINITIONS

- A. Refer to Section 01 42 00 – References.

1.05 SUBMITTALS

- A. Comply with the requirements and procedures of Section 01 33 00 - Submittal Procedures.

1.06 QUALITY ASSURANCE

- A. Personnel Qualifications
 - 1. Site Health and Safety Officer
 - a. Site Health and Safety Officer (SHSO) shall have minimum of five years direct construction safety experience.
 - b. Have appropriate training to supervise HAZWOPER activities.

1.07 ROLES AND RESPONSIBILITIES

- A. Site Health and Safety Officer
 - 1. Responsibilities include, but are not limited to, the following:

SECTION 01 35 29.13 - HEALTH, SAFETY, AND EMERGENCY RESPONSE PROCEDURES FOR CONTAMINATED SITES

- a. Supervising the implementation of the HASP;
 - b. Providing health and safety orientation to Contractor's personnel, subcontractors, and visitors.
 - c. Attending pre-construction conferences, progress meetings, and other project meetings, as required;
 - d. Preparing and maintaining health and safety records and statistics;
 - e. Leading and documenting daily job safety briefings / tailgate safety meetings;
 - f. Leading incident investigations on the Contractor's behalf and preparing and submitting incident reports; and
 - g. Maintaining a continuous Health and Safety Monitoring Program throughout the performance of the Work, including coordination/communication with Engineer, who will occasionally observe/monitor safety performance of Contractor and its subcontractors. It shall be Contractor's responsibility to notify Engineer of any deviations from the Health and Safety Monitoring Program.
2. SHSO shall be on-Site for the full duration of the Work anytime Contractor's personnel, subcontractors, or visitors are on-Site.
 3. SHSO shall be dedicated to the project. If Contractor elects to change or replace the individual serving as SHSO, the individual shall meet all the requirements as set forth in this Section and notify Engineer five days prior to the change.
- B. General Personnel
1. Contractor shall ensure all Contractor's personnel, subcontractors, or visitors comply with the requirements of the HASP.
 2. Contractor's personnel, subcontractors, or visitors that fail to comply with the requirements of the HASP shall be removed from the Site. Individuals removed from the Site for failure to comply with the HASP shall not return without Engineer's concurrence. Engineer reserves the right to require Contractor's personnel and subcontractors to undertake supplemental training prior to their return.

1.08 INCIDENT REPORTING AND INVESTIGATION

- A. Immediately notify Engineer and Owner of all incidents that:
1. Result in bodily injury, illness, or property damage.
 2. Affect the environment; or
 3. Involve the public.
- B. Submit an incident report to Engineer and Owner within 24 hours after an incident occurs. An incident report, at minimum, shall include:
1. Date, time, and location of incident;
 2. Names of personnel involved or affected by the incident;
 3. A description of the incident and activities being performed immediately prior to the incident occurring;

SECTION 01 35 29.13 - HEALTH, SAFETY, AND EMERGENCY RESPONSE PROCEDURES FOR CONTAMINATED SITES

4. Medical treatment administered, if any;
 5. The nature and seriousness of injury or damage; and
 6. The root cause of the incident and corrective actions to reduce the probability of the incident reoccurring.
- C. Comply with 26 CFR 1904, including using OSHA 300, 300-A, and 301 forms (or equivalent) to document all incidents that result in bodily injury.
- D. Based upon the result of the incident investigation amend the HASP.

1.09 TRAINING, MEDICAL MONITORING, INFORMATION, AND COMMUNICATION

- A. Prior to the initiation of the Work, Contractor shall verify that personnel that will be directly or indirectly involved in intrusive work have received appropriate training in compliance with 29 CFR 1910.120 (i.e., HAZWOPER) and 29 CFR 1926 (i.e., Safety and Health Regulations for Construction), including initial 40-hour Initial Training and Annual 8-hour refreshers, as well as 8-hour Supervisor Training for individuals in a supervisory role.
- B. Contractor's personnel that will work in exclusion zones and contamination reduction zones, and/or will contact contaminated environmental media at the Site shall be enrolled in a periodic medical monitoring in accordance with 29 CFR 1910.120 (f), at a frequency recommended by a physician, but no less frequent than biennial.
- C. Ensure that only personnel having successfully completed the required training and medical surveillance, commensurate with their work, are permitted to perform the Work at the Site, and records of such training and medical surveillance shall be maintained by Contractor at the Site. It will be the individual employer's responsibility to provide requisite training and medical surveillance to its employees and to ensure subcontractors' employees are qualified as such.
- D. At least one individual, designated by Contractor and its subcontractors, who has current certification (Red Cross or equivalent) in basic first aid, cardiopulmonary resuscitation (CPR) and operation of Automated External Defibrillators (AEDs) must be present at each active work location on the Site at all times during work activities. First-aid-trained personnel must also have received training and information regarding OSHA's Bloodborne Pathogen Standard, including the required use of "universal precautions."
- E. Prior to the initiation of the Work and as part of the project kick-off meeting, SHSO shall attend a process safety review meeting with Engineer to evaluate the hazards associated with the Work and risk reduction and mitigation measures.
- F. Implement an on-Site safety program that includes Site safety orientations, daily job safety briefings / tailgate safety meetings, and regular/periodic safety meetings. Personnel shall be encouraged during the Site safety orientation and periodically thereafter to report unsafe work practices or workplace conditions to their supervisor and/or SHSO, and to discontinue or delay their work ("stop work") should it represent an imminent hazard or otherwise unacceptable safety risk.
- G. Ensure that all required postings are in place, including, but not limited to OSHA poster, applicable labor and wage posting, and emergency response contact information.
- H. Comply with additional training requirements applicable to the Work and required by law and regulations.

SECTION 01 35 29.13 - HEALTH, SAFETY, AND EMERGENCY RESPONSE PROCEDURES FOR CONTAMINATED SITES

1.10 HAZARD COMMUNICATION

- A. Upon observing or becoming aware of any unsafe condition which poses an imminent danger to on-site personnel, visitors, or the general public, Contractor shall “stop work” and notify the individual(s) affected, their supervisor, and Engineer of the condition and of corrective actions to be taken.
- B. Contractor shall ensure Safety Data Sheets for chemicals brought on-Site by Contractor and their subcontractors are maintained at the Site, and made available to Engineer and other affected personnel upon request.

1.11 SAFETY MEETINGS

- A. Contractor shall, at minimum, conduct daily safety meetings to discuss health and safety related issues. The Safety Meeting shall be conducted by Contractor’s SHSO, and attend by Contractor’s resident supervisors, all Contractor’s employees at the site, and Subcontractors involved in the Work during the day. Engineer may attend safety meetings. The topics shall include: safety problems, security, close calls, near misses, the potential risk of planned activities, coordination of equipment movement/Work Area, and requirements related to upcoming Work.

1.12 LOGS, REPORTS, AND RECORD KEEPING

- A. Contractor shall maintain logs and reports covering the implementation of the HASP and other requirements of this Section. The formats shall be developed by Contractor and the template format submitted as part of the HASP.

1.13 PERSONAL PROTECTIVE EQUIPMENT

- A. Minimum personal protective equipment (PPE) to be worn during the Work includes: hard hat, safety-toe boots, safety glasses, and high-visibility vest, shirt, or outwear, as appropriate for the environmental conditions.
- B. Additional PPE shall be used and task being performed as determined by Contractor.
- C. Contractor shall oversee all use of PPE necessary to be in compliance with the HASP.
- D. Contractor shall make PPE available for use by Site visitors.

PART 2 - PRODUCTS

2.01 MATERIALS

- A. Not Used

2.02 EQUIPMENT

- A. Personal Protective Equipment
 - 1. Personal protective equipment and protective clothing for use by all Contractor’s employees shall be consistent with the levels of protection for this Work as indicted in the Contractor’s Health and Safety Plan.
- B. All clothing and equipment must conform to the OSHA and EPA requirements as indicated in Section 01 41 00 – Regulatory Requirements. Generally, protective clothing is considered disposable, but respiratory equipment is reusable. The Contractor will be required to monitor the excavation using the equipment described in the Contractor’s HASP.
- C. The items to be furnished by the Contractor under different levels of required protection for their own personnel and subcontractor’s personnel include, but are not limited to the following:

SECTION 01 35 29.13 - HEALTH, SAFETY, AND EMERGENCY RESPONSE PROCEDURES FOR CONTAMINATED SITES

1. Level D Protection:
 - a. Coveralls (cotton or Tyvek)
 - b. Gloves
 - c. Safety boots
 - d. Safety glasses
 - e. Hard hat
2. Modified Level D Protection:
 - a. Items 1a through 1e above with chemical resistant coveralls, gloves and boot covers, as appropriate, and without a respirator.
3. Level C Protection:
 - a. Full-body coveralls (Tyvek or equivalent)
 - b. Head cover
 - c. Boot covers
 - d. Gloves
 - e. Air Purifying Respirator
4. Levels B and A represent increased levels of protection and are described in the standards.

PART 3 - EXECUTION

3.01 IMPLEMENTATION

- A. Contractor is responsible for ensuring that all health and safety requirements are implemented in accordance with the HASP and applicable laws and regulations. The Contractor shall provide adequate health and safety training for all personnel who may come in contact with or be exposed to contaminated materials during Work. Owner and Engineer will not be responsible at any time for Contractor's violation of pertinent Local, State, or Federal regulations or endangerment of construction workers, passers-by, or any others.
- B. The Owner and Engineer will not be held negligent nor liable for any inadequacies or deficiencies in the Contractor's Worker Health and Safety Plan or for any oversight or inadequacies in the Contractor's implementation of the Worker Health and Safety Plan.
- C. Minimum precautions noted in this Section shall in no way relieve the Contractor of his responsibility for implementing stricter health and safety precautions should they be warranted by the work.
- D. Engineer reserves the right to monitor, from time to time, the health and safety performance of Contractor and its subcontractors, and report to Owner deficiencies and non-compliances.

END OF SECTION

SECTION 01 41 00 – REGULATORY REQUIREMENTS

PART 1 - GENERAL

1.01 SUMMARY

- A. This Section includes information relative to applicable regulatory requirements including, but not limited to, federal, state, and local Laws and Regulations; codes; standards, criteria, and guidance; and other regulations and requirements set forth by authorities having jurisdiction.
- B. Portions of this specification shown in *italics* were prepared by the Hydraulic Engineer (Streamworks, PLLC) for floodplain restoration work. That work is covered by the Restoration Contract being led by Streamworks PLLC and is separate from the Remedial Contract with Sanborn Head.

1.02 RELATED SECTIONS

- A. All Drawings and Technical Specifications are related to this Section.

1.03 REFERENCES

- A. Laws and Regulations: Comply with local, state, and federal regulations including, but not limited to, the following:
 - 1. Title 29 Code of Federal Regulations (CFR) Part 1926 (29 CFR 1926) – Safety and Health Regulations for Construction
 - 2. 29 CFR 1910.120 - Hazardous Waste Operations and Emergency Response
 - 3. 29 CFR 1926 – Safety and Health Regulations for Construction
 - 4. New Hampshire Code of Administrative Rules Env (Department of Environmental Services) Subtitle Env-Or (Oil and Remediation Programs)
 - 5. New Hampshire Code of Administrative Rules Env (Department of Environmental Services) Subtitle Env-Sw (Solid Waste Programs)
 - 6. *New Hampshire Code of Administrative Rules Env (Department of Environmental Services) Subtitle Env-Wt (Wetlands)*
 - 7. *New Hampshire Code of Administrative Rules Env (Department of Environmental Services) Subtitle Env-Wq (Water Quality)*
 - 8. USEPA National Ambient Air Quality Standards (NAAQS) for Particulate Matter (PM)
 - 9. Town of Hillsborough Town Ordinances and Regulations
- B. Codes and Standards: Comply with industry codes and standards, criteria, and guidance including, but not limited to, the following:
 - 1. The State of New Hampshire Department of Transportation (NHDOT) Standard Specifications for Road and Bridge Construction (hereinafter referred to as NHDOT Standard Specifications) and NHDOT Standard Plans for Road and Bridge Construction (hereinafter referred to as NHDOT Standard Plans), latest edition.
 - 2. *The State of New Hampshire Department of Environmental Services (NHDES) Stormwater Manual, latest edition (hereinafter referred to as NH Stormwater Manual)*
 - 3. American Association of State Highway and Transportation Officials (AASHTO) “Manual for Assessing Safety Hardware”

SECTION 01 41 00 – REGULATORY REQUIREMENTS

4. American National Standards Institute (ANSI) A10 Series standards for "Safety Requirements for Construction and Demolition"
 5. ANSI Z308.1 "Minimum Requirements For Workplace First Aid Kits And Supplies"
 6. ASTM D1557 "Standard Test Methods for Laboratory Compaction Characteristics of Soil Using Modified Effort (56,000 ft-lbf/ft³ (2,700 kN-m/m³))"
 7. ASTM D422 "Standard Test Method for Particle-Size Analysis of Soils"
 8. ASTM International (ASTM) D4397 "Standard Specification for Polyethylene Sheeting for Construction, Industrial, and Agricultural Applications"
- C. Guidance: Perform the Work in general accordance with the policies and procedures as describe in the following guidance documents:
1. National Institute of Occupational Safety and Health (NIOSH) "Occupational Safety and Health Guidance Manual for Hazardous Site Activities", October 1985, NIOSH Publication Number 85-115

1.04 DEFINITIONS

- A. Refer to Section 01 42 00 – References.

1.05 SUBMITTALS

- A. Comply with the requirements and procedures of Section 01 33 00 - Submittal Procedures.
- B. Provide a copy of all permits and approvals to Engineer in accordance with Section 01 33 00 - Submittal Procedures.

1.06 QUALITY ASSURANCE

- A. Specific reference to laws and regulations, codes, and standards shall mean the latest version in effect at the time of opening of Bids, except as may otherwise be specified or expressly stated in the Contract Documents.
- B. Reference codes establish minimum requirements. Where provisions of various codes or standards conflict, the more stringent provision shall govern.
- C. Should any conditions develop not covered by the Contract Documents wherein the Work will not comply with laws and regulations, codes, and standards, a Change Order detailing and specifying the required Work shall be submitted in accordance with the procedures in the Contract Documents.

1.07 PRECEDENCE:

- A. Where Drawings or Technical Specifications require or describe products or execution of better quality, high standard, or greater size or quantity than required by applicable laws and regulations, codes, and standards, Drawings or Technical Specifications shall take precedence as long as such increase is legal.
- B. Where no requirements are defined or identified within the Drawings or Technical Specifications, comply with laws and regulations, codes, and standards of authorities having jurisdiction.
- C. Where conflicts exist between regulatory requirements: Comply with the one establishing the more stringent requirement.

SECTION 01 41 00 – REGULATORY REQUIREMENTS

- D. Where conflicts exist between referenced regulatory requirements and Contract Documents: Comply with the one establishing the more stringent requirement.

1.08 PERMITS

- A. Contractor is responsible for verifying and obtaining permits applicable to the Work that are not obtained by the Engineer or Hydraulic Engineer.
- B. Contractor is responsible for payment of permit fees. Contractor's cost for compliance with applicable permits shall be considered incidental to the Work, and not a direct cost except as may otherwise be specified or expressly stated in the Contract Documents.
- C. Engineer will coordinate delivery of Contractor submittals to authorities having jurisdiction, as may be required.
- D. When necessary, Engineer may provide data summaries or other Project information in support of Contractor permit submittals.
- E. Any coordination and assistance between Contractor and Engineer are provided in the interest of expediting the Project. Provision of coordination and assistance does not relieve Contractor of any obligations in obtaining the required permits or in providing authorities having jurisdiction complete and accurate information as it relates to Project permits.
- F. *The permit applications listed below will be submitted concurrently with the bidding process and will be made available to the winning bidder as soon as possible. When obtained, comply with the permits and their conditions given for the project:*
 - 1. *NHDES Wetland permit*
 - 2. *US ACOE General permit*

1.09 CONFORMANCE

- A. Contractor shall give all notices required by and shall comply with all regulatory requirements applicable to the performance of the Work. Neither Owner nor Engineer shall be responsible for monitoring Contractor's compliance with any regulatory requirements.
- B. If Contractor performs any Work or takes any other action knowing or having reason to know that it is contrary to laws and regulations, codes, and standards, Contractor shall bear all resulting costs and losses, and shall indemnify and hold harmless Owner and Engineer.

PART 2 - PRODUCTS

Not Used

PART 3 - EXECUTION

Not Used

END OF SECTION

SECTION 01 42 00 – REFERENCES

PART 1 - GENERAL

1.01 SUMMARY

- A. This Section includes lists of definitions, abbreviations, and acronyms used in conjunction with the Work.

1.02 RELATED SECTIONS

- A. All Drawings and Technical Specifications are related to this Section.

1.03 REFERENCES

- A. Refer to Section 01 41 00 – Regulatory Requirements

1.04 DEFINITIONS

- A. Accepted – Means accepted by Engineer when used in conjunction with Engineer’s duties and responsibilities as stated in the Contract Documents.
- B. Approved - Where used in conjunction with Engineer’s response to submittals, requests, applications, inquires, reports, and claims by Contractor, the meaning of the term “approved” will be held to limitations of Engineer’s responsibilities and duties as specified in the Contract Documents. Where the terms “or approved” or “as approved” or “for approval” are used, Engineer is the sole judge of the quality and suitability of the proposed substitutions. In no case will “approval” by Engineer be interpreted as a release of Contractor from responsibilities to fulfill requirements of the Contract Documents. Whenever a material, article or piece of equipment is identified on the Drawings or Technical Specification by reference to manufacturer’s or vendor’s names, trade names, catalog numbers, or the like, and followed by the wording “or approved”, “or approved substitute” or “equivalent, as approved”, it is so identified for the purpose of establishing a standard, and any material, article, or piece of equipment of other manufacturers or vendors which will perform adequately the duties imposed by the general design will be considered equally acceptable provided the material, article, or piece of equipment so proposed is, in the opinion of Engineer, of equivalent substance, quality, appearance or function and has been approved by Engineer in writing prior to bid opening in conformance with the Contract Documents. It shall not be purchased or installed by the Contractor without Engineer’s and Owner’s prior written approval.
- C. As required – Means as required to suitably complete the Work in accordance with the Contract Documents.
- D. Authority Having Jurisdiction – Means the entity which has responsibility related to implementing and enforcing Laws and Regulations, codes, standards, etc. related to the Work or a portion of the Work.
- E. Concealed – Means out of sight. Such as above ceiling, below floors, between walls, pipe and duct shafts, and similar spaces that are not readily accessible and observable.
- F. Coordinate – Means to facilitate scheduling and sequencing of the Work among all parties to assure efficient and orderly sequence of interdependent Work elements for completion of this Project.
- G. Demolish – Means to remove in whole or in part structures and engineered surfaces without damaging adjacent structures and engineered surfaces.
- H. Directed – Terms such as “directed”, “requested”, “authorized”, “selected”, “approved”, “required”, and “permitted” mean directed or requested by Engineer. No such implied meaning shall be interpreted to extend Engineer’s responsibility into Contractor’s area of construction supervision. Means and methods of construction are the sole responsibility of Contractor.

SECTION 01 42 00 – REFERENCES

- I. Engineer – Means consultants to Owner as listed in the Contract Documents, which includes Sanborn, Head & Associates, Inc., and Streamworks, PLLC.
- J. Experienced – When used with respect to any trade in connection to the Work, means having successfully completed a minimum of 5 substantially similar (in size and scope) projects, being familiar with the requirements indicated, and aware of compliance with Laws and Regulations, codes, standards, etc. related to the Work.
- K. Exposed – Mean open to view and not covered or concealed.
- L. Furnish – Means to supply and deliver to Project site, ready for unloading, unpacking, assembly, installation, and similar operations.
- M. Indicated – Means graphic representations, notes, or schedules on the Drawings, within the Technical Specifications, and similar requirements in the Contract Documents. Terms such as "shown," "noted," "scheduled," and "specified" are used to help the reader locate the reference. Location is not limited and is applicable where reasonably implied and necessary in conformance with work specified, drawn, or required for completion.
- N. Inspection - As used in reference to actions of Engineer, shall mean to review or observe the Work, but not to “inspect” the Work as the Contractor or authority having jurisdiction will inspect.
- O. Install – Means accordance with Manufacturer’s literature, unless otherwise noted or directed, for the best results. In the event of conflict between the Manufacturer’s literature, or its literature and the Contract Documents, Contractor shall submit the discrepancy or conflict to Engineer for resolution and written instruction prior to proceeding with any work. No Manufacturer preparatory steps or installation procedures may be omitted. If the Contract Documents generalize the installation procedure, but do not necessarily mention all procedures, those procedures are not exempt from being completed by Contractor unless they are specifically modified or stated as being exempt.
- P. Laws and Regulations - Means laws, ordinances, statutes, and lawful orders issued by authorities having jurisdiction, as well as rules, conventions, and agreements within the construction industry that control performance of the Work.
- Q. Means and methods – Means techniques, procedures, and materials used during the construction process including sequences, procedures, and safety precautions. Means and methods are the sole responsibility of Contractor.
- R. Owner – Means the Town of Hillsborough and the New Hampshire Department of Environmental Services (NHDES).
- S. Remove - Means to detach items from the existing construction and legally dispose of off- site unless indicated otherwise.
- T. Repair - Means to perform minor corrections and patching of all indicated materials.
- U. Replace - Means to provide new material to match adjacent materials, unless noted otherwise.
- V. As Required - Means to complete the Work in a first-class workmanship manner.
- W. Satisfactory – Means acceptable to Engineer and owner, Engineer shall be the sole judge of the acceptability.
- X. Similar – Means in the Contract Documents, having common features and consistent with but not necessarily be identical to related portions of the Work.

SECTION 01 42 00 – REFERENCES

Y. Verify – Means Contractor is to confirm conditions and coordinate any variations with Engineer.

1.05 SUBMITTALS

A. Not used.

1.06 QUALITY ASSURANCE

A. Not used.

PART 2 - PRODUCTS

Not Used

PART 3 - Execution

Not Used

END OF SECTION

SECTION 01 45 00 – QUALITY CONTROL

PART 1 - GENERAL

1.01 SUMMARY

- A. This Section includes requirements encompassing quality control of the Work.

1.02 RELATED SECTIONS

- A. Section 01 11 00 – Summary of Work.
- B. Section 02 61 13 – Excavation and Handling of Contaminated Materials.
- C. Section 31 20 00 – Earth Moving.
- D. Section 32 91 19.13 – Topsoil Placement and Grading.
- E. Section 32 92 19.16 – Hydraulic Seeding.

1.03 REFERENCES

- A. Refer to Section 01 41 00 – Regulatory Requirements.

1.04 DEFINITIONS

- A. Refer to Section 01 42 00 – References.

1.05 SUBMITTALS

- A. Comply with the requirements and procedures of Section 01 33 00 - Submittal Procedures.

1.06 GENERAL QUALITY CONTROL

- A. The Contractor shall maintain quality control over the suppliers, manufacturers, products, services, site conditions, and workmanship to produce work of specified quality.
- B. The Contractor shall comply with industry standards except when more restrictive tolerances or specified requirements indicate more rigid standards or more precise workmanship.

1.07 OBSERVATION AND TESTING FOR QUALITY CONTROL

- A. This Section does not address sampling and testing for laboratory analysis of soil for confirmatory or disposal purposes. Confirmatory and disposal analysis will be completed by the Engineer as discussed in Section 02 61 13 – Excavation and Handling of Contaminated Materials.
- B. The Owner will employ and pay for the services of an Engineering Firm(s) to administer the Construction Agreement and perform construction observation. These services will be performed in accordance with the requirements of governing authorities, to establish whether the work is in accordance with the Drawings and Technical Specifications.
- C. The Contractor shall cooperate with the Engineer, and furnish tools, equipment, samples of materials, and assistance as requested.

SECTION 01 45 00 – QUALITY CONTROL

- D. The work shall be subject to the observation of the Owner and/or the Engineer. Observation or non-observation by the Owner and/or the Engineer shall not relieve the Contractor from his contractual obligation to furnish work and material as required, and properly complete the work in accordance with the Drawings and Technical Specifications. If the Owner or the Engineer considers that the work is not properly accomplished, he may condemn or reject all or any part of the work and any materials or equipment incorporated in it. If any material, equipment, or work is condemned or rejected by the Owner or the Engineer, the Contractor shall bear all expenses for removal and proper replacement of such material, equipment, or work replacing any work done by others which is adversely affected by removal and proper replacement of improper work done by the Contractor.

1.08 MANUFACTURER'S INSTRUCTIONS AND CERTIFICATES

- A. The Contractor shall comply with manufacturers' instructions in full detail, including each step in sequence. If instructions conflict with any Drawing or Technical Specification, then the Contractor should request clarification from the Engineer and/or Owner before proceeding.
- B. The Contractor shall submit the manufacturer's certificate that products meet or exceed the specified requirements.

1.09 SUBSTANDARD WORK OR MATERIALS

- A. Any defective or substandard work or materials furnished by the Contractor that is discovered before the final acceptance of the Work, as established by the Certificate of Substantial Completion, or during the subsequent guarantee period, shall be removed immediately even though it had been overlooked by the Engineer and recommended for payment. Any equipment or materials condemned or rejected by the Engineer shall be tagged as such and shall be immediately removed from the site. Satisfactory work or materials shall be substituted for that rejected.
- B. The Engineer may order tests on substandard or damaged work, equipment, or materials to determine the required functional capability for possible acceptance, if there is no other reason for rejection. The cost of such tests shall be borne by the Contractor and the nature, extent, and supervision of the tests will be as determined by the Engineer. If the results of the tests indicate that the required functional capability of the work, equipment, or material was not impaired, consistent with the final general appearance of same, the work, equipment, or materials may be deemed acceptable. If the results of such tests reveal that the required functional capability of the questionable work or materials was impaired, then such work or materials shall be deemed substandard and shall be replaced. The Contractor may elect to replace the substandard work or material instead of performing the tests.

PART 2 - PRODUCTS

- A. Not used.

PART 3 - EXECUTION

- A. Not Used.

END OF SECTION

SECTION 01 50 00 – TEMPORARY FACILITIES AND CONTROLS

PART 1 - GENERAL

1.01 SUMMARY

- A. This Section includes requirements for temporary facilities and controls to be provided by the Contractor necessary for the completion of the Work.

1.02 RELATED SECTIONS

1. Section 01 11 00 – Summary of Work
2. Section 01 33 00 – Submittal Procedures
3. Section 01 35 29.13 – Health, Safety, and Emergency Response Procedures for Contaminated Sites
4. Section 01 57 13 – Temporary Erosion and Sediment Control
5. Section 01 57 26 – Site Watering and Dust Control

1.03 REFERENCES

- A. Refer to Section 01 41 00 – Regulatory Requirements.

1.04 DEFINITIONS

- A. Refer to Section 01 42 00 – References.

1.05 SUBMITTALS

- A. Comply with the requirements and procedures of Section 01 33 00 – Submittal Procedures.
- B. Refer to Section 01 33 00 – Submittal Procedures for a listing of submittals required under this Section.

1.06 QUALITY ASSURANCE

- A. Inspections:
 1. Contractor shall conduct a Site inspection at least once every seven calendar days. The inspection shall ensure all temporary facilities and controls are in good working order, clean, safe, and maintained in effective operating condition and performing as intended. The inspection will also include a weekly stormwater inspection to ensure all stormwater and erosion control features are performing as intended. The stormwater inspection shall be documented and submitted to Engineer in accordance with Section 01 33 00 - Submittal Procedures.

PART 2 - PRODUCTS

2.01 MATERIALS

- A. Water, Potable: Provide potable water.
- B. Portable Chain-Link Fencing with locking gate (see Section 3.04 herein).

2.02 EQUIPMENT

- A. Fire Extinguishers: Provide hand-carried, portable, UL-rated Class ABC, dry chemical fire extinguishers or a combination of extinguishers of NFPA-recommended classes for the exposures.

SECTION 01 50 00 – TEMPORARY FACILITIES AND CONTROLS

1. Comply with NFPA 10 and NFPA 241 for classification, extinguishing agent, and size required by location and class of fire exposure.
 - B. First Aid Stations: Provide temporary first aid stations at or immediately adjacent to the major work areas. Locations to be determined by Contractor. At a minimum, first aid stations shall be equipped with:
 1. One first aid kit complying with ANSI Z308.1.
 2. One eyewash station complying with ANSI Z358.1.
 - C. Spill Response Kit: Provide a spill response kit on-Site at all times of sufficient size to contain and absorb the capacity of the largest fuel or hydraulic fluid tank of Contractor-provided equipment.
- 2.03 TEMPORARY FACILITIES
- A. Temporary Sanitary Facilities, Toilets: Provide portable sanitary facilities for use by all project personnel.
 - B. Temporary Sanitary Facilities, Drinking Water: Provide portable sanitary facilities for use by all project personnel.
 - C. Temporary Enclosures: Where required to protect materials and equipment and where elected by Contractor, provide weather-tight enclosures (e.g., shed, portable storage container, etc.).

PART 3 - EXECUTION

3.01 GENERAL

- A. The Contractor shall provide all temporary facilities necessary for the successful completion of the Work.
- B. The Contractor shall establish and initiate use of each temporary facility when it is reasonably required for proper performance of the Work, and shall terminate the use of, and remove from the site, the facilities when no longer needed or when directed to do so by the Engineer.
- C. The Contractor shall maintain areas outside the limits of work free of waste materials, debris, and rubbish that are a direct result of work performed by the Contractor.
- D. Use qualified personnel for installation of temporary facilities and controls. Locate facilities and temporary utilities where they will service the Work adequately and result in minimum interference with the performance of the Work. Relocate and modify the location of facilities as required by the progress of the Work.
- E. Keep temporary facilities clean and orderly in appearance. Maintain controls in accordance with these Technical Specifications, permits, and other applicable requirements. Do not allow hazardous, dangerous, or unsanitary conditions, or public nuisance conditions develop or persist on-Site.
- F. Upon approval of Engineer, remove all temporary facilities and controls. Restore utilities and Site to a condition acceptable to the respective authority having jurisdiction and Owner.

3.02 TEMPORARY FACILITIES

- A. There are no facilities available to the Contractor at the site. Temporary facilities provided by the Contractor, as needed to complete the Work, shall include:
 1. Drinking water;
 2. Potable water for dust control, hydroseeding, and to facilitate soil compaction;

SECTION 01 50 00 – TEMPORARY FACILITIES AND CONTROLS

3. Portable sanitary facilities for use by all project personnel; and
 4. Electricity for Contractor's use (if needed).
- B. The Contractor shall install, operate, maintain, and protect temporary facilities in a manner that shall be safe, non-hazardous, sanitary, and protective of persons and property. Facility locations selected by the Contractor shall be reviewed and accepted by the Engineer prior to their implementation.
 - C. The Contractor shall terminate the use of, and remove from the site, the facilities when no longer needed or when directed to do so by the Engineer.
 - D. The Contractor shall maintain areas outside the limits of work free of waste materials, debris, and rubbish that are a direct result of work performed by the Contractor.

3.03 TEMPORARY CONTROLS

- A. The Contractor shall provide and pay for barriers, including but not limited to temporary perimeter fencing (see Section 3.04 herein), to prevent unauthorized entry to construction areas and to protect existing facilities and adjacent properties from damage from construction operations.
- B. The Contractor shall protect installed work, provide special protection where specified in individual specification sections, and provide temporary and removable protection for installed products. It is the responsibility of the Contractor to minimize erosion of, or fugitive dust resulting from, placed material or material stockpiles by providing the proper materials and equipment to adequately seal the surface of such materials. At the request of the Owner or Engineer, the Contractor shall immediately install additional temporary protection as deemed necessary by the Owner or Engineer.
- C. The Contractor shall be responsible for controlling dust generated during performance of the Contract work. The Contractor shall use potable water to control dust and implement dust control measures as specified in Section 01 57 26 – Site Watering and Dust Control.
- D. The Contractor shall furnish all labor, materials, tools, and equipment, and perform all operations necessary for erosion and sedimentation control work as indicated on the Drawings and as specified in Section 01 57 13 – Temporary Erosion and Sediment Control. The Contractor shall provide filter logs and other structures needed to filter stormwater. Erosion and sediment controls must be in place and accepted by the Engineer prior to initiating earthwork activities.

3.04 FENCING

- A. Contractor is responsible for reviewing the Drawings and verifying existing conditions prior to the beginning of the Work.
- B. If the existing fence and locking gate is deemed insufficient in controlling and securing access to the Work by the Engineer or Owner, the Contractor shall furnish all labor, materials, tools, and equipment, and perform all operations necessary to either a) remove and dispose of the existing fencing and gate and install fencing with a locking gate following a similar extent as the existing fencing and gate structures; or b) repair the existing fence and gate until deemed sufficient in controlling access to the Work by the Engineer or Owner. The gate shall be equipped with a lock, and remain locked during non-working hours. Keys shall be provided to Engineer and Owner, upon request.
- C. Maintain and inspect the existing or temporary fencing for the duration of the Work. Temporary fencing shall be ballasted to prevent tipping and displacement from wind, incidental strikes, etc.

SECTION 01 50 00 – TEMPORARY FACILITIES AND CONTROLS

3.05 SITE MAINTENANCE

- A. During progression of the Work, all Work areas shall be kept clean, all rubbish shall be removed on a daily basis, and all surplus materials and unneeded construction equipment shall be removed from the site when no longer required for the Work.
- B. When Contractor's operations have allowed or caused material or debris to enter existing watercourses, ditches, drains, pipes, or structures, such material or debris shall be removed and disposed during the progress of the Work.
- C. At the completion of the Work, the Contractor shall remove all rubbish from any grounds that they have occupied, and shall leave the roads and all parts of the premises affected by their operations in a neat and clean condition.
- D. The Contractor shall restore or replace, when and as directed, any property damaged by their Work, equipment, or employees, to pre-existing conditions.
- E. The Contractor shall remove temporary above-grade or buried utilities, equipment, facilities, construction entrances, and materials prior to Substantial Completion inspection. The Contractor shall restore existing and permanent facilities used during construction to original or better condition.

END OF SECTION

SECTION 01 57 13 – TEMPORARY EROSION AND SEDIMENT CONTROLS

PART 1 - GENERAL

1.01 SUMMARY

- A. This Section includes requirements for temporary erosion and sedimentation controls.
- B. The Contractor shall furnish all labor, materials, tools, and equipment, and perform all operations necessary for erosion and sedimentation control work as indicated on the Drawings and as specified herein. The Contractor shall provide filter logs and other structures needed to filter stormwater. Erosion and sediment controls must be in place and accepted by the Engineer prior to initiating earthwork activities.
- C. The Contractor shall review the Stormwater Pollution Prevention Plan (SWPPP) prepared by the Engineer, in accordance with the requirements of the National Pollutant Discharge Elimination System (NPDES) Construction General Permit (CGP).
 - 1. It is the responsibility of the Contractor to be familiar with the conditions of the CGP and the SWPPP, perform all related inspections and reports, and implement all corrective actions necessary to comply with the CGP/SWPPP requirements.
 - 2. Any inspection reports or other documentation required by the CGP/SWPPP are to be prepared by the Contractor, and copies shall be provided to the Engineer (see Section 01 33 00 – Submittal Procedures).
- D. The Contractor shall prepare and submit to the USEPA the CGP Notice of Intent (NOI) as indicated in Section 01 33 00 – Submittal Procedures.
- E. Portions of this specification shown in *italics* were prepared by the Hydraulic Engineer (Streamworks, PLLC) for floodplain restoration work. That work is covered by the Restoration Contract being led by Streamworks PLLC and is separate from the Remedial Contract with Sanborn Head.

1.02 RELATED SECTIONS

- 1. Section 01 11 00 – Summary of Work
- 2. Section 01 33 00 – Submittal Procedures
- 3. Section 01 35 29.13 – Health, Safety, and Emergency Response Procedures for Contaminated Sites
- 4. Section 01 57 26 – Temporary Facilities and Controls
- 5. Section 02 61 13 – Excavation and Handling of Contaminated Materials
- 6. *Section 31 23 19 – Dewatering*

1.03 REFERENCES

- A. Refer to Section 01 41 00 – Regulatory Requirements.

1.04 DEFINITIONS

- A. Refer to Section 01 42 00 – References.

1.05 SUBMITTALS

- A. Comply with the requirements and procedures of Section 01 33 00 – Submittal Procedures.

SECTION 01 57 13 – TEMPORARY EROSION AND SEDIMENT CONTROLS

- B. Refer to Section 01 33 00 – Submittal Procedures for a listing of submittals required under this Section.

1.06 QUALITY ASSURANCE

A. Inspections:

1. Contractor shall conduct a Site inspection at least once every seven calendar days. The inspection shall ensure all temporary facilities and controls are in good working order, clean, safe, and maintained in effective operating condition and performing as intended. The inspection will also include a weekly stormwater inspection to ensure all stormwater and erosion control features are performing as intended. The stormwater inspection shall be documented and submitted to Engineer in accordance with Section 01 33 00 – Submittal Procedures.
2. The Contractor is responsible for ensuring all lands requiring erosion and sediment controls are protected with such during the entire course of construction including all intermediate phases of site work.

PART 2 - PRODUCTS

2.01 MATERIALS

A. Filter Logs:

1. Filter logs shall be a compost-filled bio- or photo-degradable tubular mesh product capable of trapping sediment before or within the device while allowing stormwater runoff to pass through.
2. The mesh fabric shall be clean, evenly woven, and free of encrusted concrete or other contaminating materials and free from cuts, tears, broken or missing yarns and thin, open, or weak places.
3. Each Filter Log shall have a diameter of no less than 12 inches.
4. The mesh opening shall be no smaller than $\frac{1}{8}$ inch.
5. The compost shall be derived from green material consisting of chipped, shredded, or ground vegetation, or clean recycled wood products, and be reasonably free of visible contaminants. It shall not be derived from mixed municipal solid waste and shall not contain paint, petroleum products, pesticides, or any other chemical residues harmful to animal life or plant growth. Compost shall not possess objectionable odors.
6. The Filter Log must have a minimum durability of one year after installation.

B. *Mulch Berms:*

1. *Mulch berms shall consist of material conforming to 2.01 C, below.*
2. *Mulch berms may consist of clean wood chips made using trees felled on site, though must be free from invasives and other debris.*
3. *Mulch berms shall be placed on the ground, including uneven terrain, set with a level top a minimum of 18 inches above the ground – taller where necessary to achieve a flat top.*

SECTION 01 57 13 – TEMPORARY EROSION AND SEDIMENT CONTROLS

- C. Mulch shall consist of cured straw free from primary noxious weed seeds, twigs, debris and rough or woody materials. Mulch shall be free from rot or mold and shall be acceptable to the Engineer. Alternately, mulch shall be specially processed cellulose homogeneous fiber containing no growth or germination-inhibiting factors. Processed cellulose fiber shall be manufactured in such a manner that after addition and agitation in slurry tanks with water, the fibers in the material become uniformly suspended to form a slurry when sprayed on the ground. The material shall allow homogeneous absorption and percolation of moisture. Each package of the cellulose fiber shall be marked by the manufacturer to show the air dry weight content. Mulch shall be utilized on all newly-graded subgrade and topsoil areas that cannot be seeded within ten (10) days.
- D. *Sandbag Berms:*
1. *Sandbags may be any size though larger (1 cubic yard) are preferred.*
 2. *Sandbags shall be made from clean, evenly woven, structurally sound fabric.*
 3. *Sandbags shall be fully removable from the site.*
 4. *Sandbags shall be filled with clean, homogenous sand (D10>0.33mm and D90<3.3mm) free from organic matter and gravels.*
- E. *Turbidity Curtain:*
1. *Shall be the responsibility of the Contractor, if necessary to complete the Riverside retaining wall work.*
 2. *Shall be a continuous floating turbidity barrier to contain sediment in water with marker buoys.*
 3. *Shall meet standards set by ASTM D-4439 for turbid waters.*
 4. *Shall have enough slack to reach elevation 574.0' to accommodate fluctuations in water levels during construction.*

PART 3 - EXECUTION

3.01 GENERAL

- A. Erosion and sedimentation control methods shall consider all factors that contribute to erosion and sedimentation including, but not limited to, the following:
1. Topographic features of the Project area;
 2. Types, depth, slope, and areal extent of the soils;
 3. Proposed alteration of the area;
 4. Amount of runoff from the Project area and the upgradient watershed areas;
 5. Staging of earthmoving activities; and,
 6. Temporary control measures and facilities for use during earthmoving.
- B. The Contractor shall at all times during construction provide and maintain proper equipment and facilities to remove all water entering the construction area and any excavations created as part of this Work.

SECTION 01 57 13 – TEMPORARY EROSION AND SEDIMENT CONTROLS

- C. The Contractor shall provide protection against washouts by an approved method. Any washout that occurs either in the Contractor's work area or in areas topographically below his work shall be regraded and reseeded at the Contractor's expense until an accepted vegetative stand is established.
- D. The Contractor shall maintain excess erosion control measures on site so materials are present to perform immediate maintenance or replacement.

3.02 TEMPORARY EROSION AND SEDIMENT CONTROL

- A. All temporary erosion control measures shall be installed in accordance with the manufacturer's instructions and as shown on the Drawings, or as directed by the Owner or the Engineer.
- B. Erosion control measures along the perimeter of the site shall be completely installed prior to beginning any site work.
- C. Erosion and sediment controls must be in place and accepted by the Engineer prior to initiating earthwork activities.
- D. Earthmoving activities shall be performed in such a manner as to prevent the potential for erosion and to control resulting sedimentation.
- E. The Engineer or Owner may require the installation of additional erosion and sediment controls or their replacement. The Contractor shall comply with Engineer's or Owner's request and immediately install the required controls
- F. Contractor shall inspect erosion and sediment control measures on a weekly basis, and after any storm event of 1 inch or greater precipitation, with inspection reports to be provided to the Engineer as specified in 01 33 00 Submittal Procedures
- G. Contractor shall immediately remove materials spilled, dropped, washed, or tracked onto roadways by scraping or sweeping.
- H. Filter Log, Maintenance: Remove accumulated sediment when it reaches half the height of the exposed log.
- I. *Mulch (or Wood Chip) berms shall be used in place of filter logs where filter logs are not effective, and/or as shown on the Drawings.*
- J. *Mulch Berms shall be removed and disposed of when no longer necessary, or spread in a thin (less than 1 inch) layer over the site, if not in contact with contaminated soil or sediment.*
- K. Mulch shall be applied at a rate of 100 lbs/1000 ft², if needed.
- L. *Sandbag berms shall be located as shown on the Drawings to help protect the site if the river rises. These are to remain in place for the duration of construction and be fully removed after plants have been installed.*
- M. *Turbidity curtain shall only be installed when necessary during work on the Riverside retaining wall. It must be placed fully surrounding the work limits and have enough slack to reach elevation 574.0' in the event water stage in the river rises.*
 - 1. *Alternative measures to a turbidity curtain are encouraged, proposed by the Contractor, so long as measures are sufficient to keep debris and sediment from entering the river due to Work.*

SECTION 01 57 13 – TEMPORARY EROSION AND SEDIMENT CONTROLS

- N. The erosion control measures shall be maintained and repaired as necessary throughout the course of the Work until provisional acceptance of the site vegetation by the Engineer or Owner, at which time the Contractor shall remove all remaining temporary erosion control structures, and properly dispose of accumulated sediment and temporary or permanent erosion control structures at an off-site disposal facility approved by the Engineer.

3.03 TEMPORARY STORMWATER POLLUTION CONTROL

- A. Contractor is responsible for reviewing the Drawings and verifying existing conditions prior to the beginning of the Work.
- B. Implement the erosion and sediment controls as specified herein.
- C. Comply with requirements of authorities having jurisdiction.
- D. Control stormwater runoff due to disturbance of surface cover due to construction activities for this Work.
- E. Provide perimeter control measures in and around disturbed, material staging, and stockpile areas to prevent run-on of stormwater from heavy rains.
- F. Store debris, stockpiled materials, fuel and chemicals, etc. under cover and away from precipitation and where precipitation could accumulate.
- G. Contractor shall implement good housekeeping practices to minimize the accumulation of sediment, dust, and debris within the Work area that could become mobilized with precipitation runoff.

END OF SECTION

SECTION 01 57 26 – SITE WATERING AND DUST CONTROL

PART 1 - GENERAL

1.01 SUMMARY

- A. This Section includes requirements for site water and dust controls during the Contract Work. The Contractor shall be responsible for controlling dust generated during performance of the Contract work.

1.02 RELATED SECTIONS

1. Section 01 11 00 - Summary of Work.
2. Section 01 35 29.13 – Health, Safety, and Emergency Response Procedures for Contaminated Sites.
3. Section 01 50 00 – Temporary Facilities and Controls.
4. Section 02 61 13 – Excavation and Handling of Contaminated Material.
5. Section 31 20 00 – Earth Moving.

1.03 REFERENCES

- A. Refer to Section 01 41 00 – Regulatory Requirements.

1.04 DEFINITIONS

- A. Refer to Section 01 42 00 – References.

1.05 SUBMITTALS

- A. Comply with the requirements and procedures of Section 01 33 00 - Submittal Procedures

1.06 QUALITY ASSURANCE

- A. Not used.

PART 2 - PRODUCTS

2.01 MATERIALS

- A. Water, General: Provide potable water for construction support activities (e.g., dust suppression).
 1. Potable water for dust control shall be supplied by the Contractor. It is anticipated that no potable water service will be available from the Owner.
 2. Chemical dust suppressants shall not be used.

PART 3 - EXECUTION

3.01 GENERAL

- A. The Contractor is responsible for minimizing the creation of dust from the time of mobilization through demobilization and shall furnish all temporary facilities, labor, materials, tools, and equipment, and perform all operations necessary for site watering and dust control.

SECTION 01 57 26 – SITE WATERING AND DUST CONTROL

- B. Dust control is of paramount importance during construction. The Contractor shall implement strict dust control measures during active construction periods on-site. These control measures will generally consist of water applications as required to prevent dust emissions. Engineer may perform and document the results of real-time dust monitoring using portable dust monitoring instrumentation.
- C. Water for dust control shall be supplied by the Contractor.
- D. Any deficiencies noted by Engineer in terms of dust control shall be immediately rectified by Contractor at no additional cost. Observation of visible dust after applying dust control measures shall be considered a stop work condition.
- E. Quality Control – Ambient Air Monitoring
 - 1. The United States Environmental Protection Agency (USEPA) has issued a health-based air quality standard of PM10 of 150 $\mu\text{g}/\text{m}^3$ as measured as a daily time weighted average concentration. The Engineer will monitor for dust particulates. If the dust monitoring indicates an exceedance of the dust action level of 150 $\mu\text{g}/\text{m}^3$, earth moving will cease until the Contractor implements dust suppression methods and ambient air dust levels in the breathing zone have been reduced to acceptable levels. Dust suppression procedures shall also be used routinely by the Contractor as part of normal construction operations.

END OF SECTION

SECTION 01 70 00 - EXECUTION AND CLOSEOUT REQUIREMENTS

PART 1 - GENERAL

1.01 SUMMARY

- A. This Section includes requirements for the protection of installed Work, restoration, final cleaning, and project closeout.
- B. Except as noted in the Contract Documents, the items listed in the Section are prerequisites for release of final retainage as indicated on the Application for Payment.

1.02 RELATED SECTIONS

- A. Section 01 11 00 – Summary of Work.
- B. Section 01 22 00 – Unit Prices.
- C. Section 01 33 00 – Submittal Procedures.

1.03 REFERENCES

- A. Refer to Section 01 41 00 – Regulatory Requirements.

1.04 DEFINITIONS

- A. Refer to Section 01 42 00 – References.
- B. Certification of Completion: Certificate issued by Owner stating Contractor has completed the Work and provided all required submittals as required in the Contract Documents.
- C. Final Inspection: Final review of the Work by Engineer and Owner to evaluate if issuance of Certificate of Completion is appropriate.
- D. Pre-Final Inspection Punchlist: A list of Work items remaining to be completed or Work that does not meet quality requirement as required by the Contract Documents and must be corrected by Contractor.
- E. Substantial Completion Inspection: Conducted by Engineer to verify the Work has reached Substantial Completion as defined in this Section.
- F. Substantial Completion: When the Work as described in the Contract Documents has been completed to the extent that the Owner may occupy and/or make use of the Work performed for the purposes for which it was intended. Upon substantial completion, there may be minor items, such as landscaping, etc., yet to be completed or items of Work to be corrected.
- G. Project Record Documents: all documents pertaining to completed Work that the Contract requires the Contractor to provide including, but not limited to, As-Built Drawings, product data, instructions, parts list, certified payrolls and operations, and maintenance manuals.
- H. *Certification of Completion (for Restoration work): Certificate issued by Owner or designee stating Contractor has completed the Work and provided all required submittals as required in the Contract Documents.*
- I. *Final Inspection (for Restoration work): Final review of the Work by Hydraulic Engineer and Owner to evaluate if issuance of Certificate of Completion is appropriate.*

SECTION 01 70 00 - EXECUTION AND CLOSEOUT REQUIREMENTS

- J. *Pre-Final Inspection Punchlist (for Restoration work): A list of Work items remaining to be completed or Work that does not meet quality requirement as required by the Contract Documents and must be corrected by Contractor.*
- K. *Substantial Completion Inspection (for Restoration work): Conducted by Hydraulic Engineer to verify the Work has reached Substantial Completion as defined in this Section.*
- L. *Substantial Completion (for Restoration work): When the Work as described in the Contract Documents has been completed to the extent that the Owner may occupy and/or make use of the Work performed for the purposes for which it was intended. Upon substantial completion, there may be minor items, such as landscaping, etc., yet to be completed or items of Work to be corrected.*
- M. *Project Record Documents (for Restoration work): all documents pertaining to completed Work that the Contract requires the Contractor to provide including, but not limited to, As-Built Drawings, product data, instructions, parts list, certified payrolls and operations, and maintenance manuals.*

1.05 SUBMITTALS

- A. Comply with the requirements and procedures of Section 01 33 00 - Submittal Procedures.

1.06 QUALITY ASSURANCE

- A. Not Used

1.07 PROJECT RECORD DOCUMENTS

- A. The Contractor shall submit Submittals prepared in accordance with Section 01 33 00.
- B. Contractor shall ensure entries are complete and accurate. Record information concurrent with the Work progress; not less than weekly.
- C. Contractor is responsible for making sure that all work performed, including by subcontractors, is recorded and provided to Engineer.
 - 1. Failure to provide accurate record drawings will result in the Contractor being back charged for engineering services required to correct at the applicable billing rate of the person responsible for performing the work.
 - 2. Payment for time necessary to create record drawings will be charged directly to Contractor.
- D. Technical Specifications: Legibly mark and record, at each product Section, description of actual products installed, including the following:
 - 1. Manufacturer's name and product model and number.
 - 2. Product substitutions or alternates used.
 - 3. Changes made by Addenda and modifications.
- E. As-Built Drawings: Legibly mark each item to record actual construction as follows:
 - 1. Include Contract Document modifications such as Addenda, supplementary instructions, change directives, field orders, minor changes in the Work, and change orders.
 - 2. Include locations of concealed elements of the Work.
 - 3. Identify and locate existing buried or concealed items encountered during the Work.

SECTION 01 70 00 - EXECUTION AND CLOSEOUT REQUIREMENTS

4. Measured horizontal and vertical locations of existing and remaining underground utilities and appurtenances, referenced to permanent surface improvements.
 5. Field changes of dimension and detail.
 6. Details not on original Drawings.
 7. Topography of all disturbed lands and relevant site features (retaining walls, habitat features, monuments or benchmarks, fencing, etc.)
- F. Submit marked-up paper copy documents and PDF electronic files of marked up documents to Engineer prior to Final Inspection.
- G. *Subsequent Final Inspection and Approval, transmit digital files for the survey drawings and all supporting files. These are necessary to comply with long-term monitoring efforts required by the grant funds and permits, to compare the built site to pre-construction, proposed, and future surveys. Files required shall include, but are not limited to:*
1. *Drawing files containing all linework in AutoCAD (.dwg) 2018 or later*
 2. *Point files of the survey (.csv, .txt) and control points used*
 3. *Surfaces, alignments, sections, or other supporting information which may be included in a LandXML file (.xml)*

PART 2 - PRODUCTS

2.01 MATERIALS

- A. Not Used

PART 3 - EXECUTION

3.01 PROTECTION OF INSTALLED WORK

- A. Contractor shall be responsible for protection of installed Work. Where specified in the Contract Documents special protection shall be provided for individual items of the Work.
- B. Provide temporary and removable protection for installed Work. Control activities such to prevent damage of installed Work.

3.02 RESTORATION

- A. Contractor shall take all steps necessary to prevent damage to existing improvements.
- B. All areas disturbed by Contractor shall be restored to original condition or better and approved by Engineer.
- C. Contractor shall be responsible for any maintenance and care (i.e., watering vegetative surfaces) until the item has been restored to its original condition as deemed by Engineer.

3.03 FINAL CLEANING

- A. Contractor shall perform Final Cleaning prior to Final Inspection.
- B. Final Cleaning shall consist of cleaning exterior surfaces, removal of temporary construction, removal of waste and surplus materials, rubbish, temporary erosion control features, and construction facilities from the project area.

SECTION 01 70 00 - EXECUTION AND CLOSEOUT REQUIREMENTS

- C. Clean site, sweep paved areas, rake clean landscaped surfaces.

3.04 CLOSE OUT PROCEDURES

- A. The Contractor shall apply for a Certificate of Substantial Completion.
- B. The Contractor shall submit a written certification that the Contract Documents were reviewed and that the Work is complete in accordance with the Contract Documents and ready for Substantial Completion inspection.
- C. Within seven days of receipt of request for Substantial Completion, Engineer will inspect to determine whether Work or designated portion is substantially complete.
 - 1. Should Engineer determine that Work is not substantially complete:
 - a. Engineer will promptly notify Contractor in writing, stating reasons for opinion.
 - b. Contractor shall remedy deficiencies in Work and resolve any discrepancies highlighted in Engineer's opinion and submit a second written request for Substantial Completion to Engineer.
 - c. Engineer will reinspect the Work.
 - d. Redo and Inspection of Deficient Work: Repeated until Work passes Engineer inspection.
 - 2. When Engineer determines the Work is substantially complete, Engineer will:
 - a. Prepare Certificate of Substantial Completion on EJCDC C-625 - Certificate of Substantial Completion (or similar form), accompanied by a list of items to be completed or corrected as prepared by Engineer (Pre-Final Inspection Punchlist).
 - b. Submit Certificate to Owner and Contractor for their written acceptance of responsibilities assigned to them in Certificate.
 - 3. After the Work is substantially complete, Contractor shall complete the Work items on the Pre-Final Inspection Punchlist within the period specified in the Contract Documents.
- D. The Contractor shall perform the Final Cleaning prior to final site inspection by the Owner and Engineer.
- E. Final Inspection
 - 1. Within seven days of receipt of request for Final Inspection, Engineer will inspect to determine whether Work or designated portion is complete.
 - 2. Should Engineer determine that Work is not complete:
 - a. Engineer will promptly notify Contractor in writing, stating reasons for opinion.
 - b. Contractor shall remedy deficiencies in Work and resolve any discrepancies highlighted in Engineer's opinion and submit a second written request for Final Completion to Engineer.
 - c. Engineer will reinspect the Work.
 - d. Redo and Inspection of Deficient Work: Repeated until Work passes Engineer inspection.
 - 3. When Engineer determines the Work is complete, Engineer will:

SECTION 01 70 00 - EXECUTION AND CLOSEOUT REQUIREMENTS

4. Prepare Certificate of Final Completion.
 5. Submit Certificate to Owner and Contractor for their written acceptance of responsibilities assigned to them in Certificate.
- F. Prior to the final application for payment, the Contractor shall submit applicable warranty documents from subcontractors, suppliers, and manufacturers. For items of work delayed materially beyond the date of substantial completion, the Contractor shall provide an updated submittal within 10 days after acceptance, listing the date of acceptance as start of warranty period. A written full warranty must be submitted for all work performed covering a period of one year from the date of Final Completion.
- G. All items in 3.04 A-F apply to both Remediation and Restoration work, as appropriate to the Work contained in each Contract.

END OF SECTION

Division 02

Existing Conditions

SECTION 02 21 00 – SURVEYS

PART 1 - GENERAL

1.01 SUMMARY

- A. Section describes the general provisions applicable to assessing, protecting, maintaining, and coordinating the Work as it relates to surveying.
- B. Portions of this specification shown in *italics* were prepared by the Hydraulic Engineer (Streamworks, PLLC) for floodplain restoration work. That work is covered by the Restoration Contract being led by Streamworks PLLC and is separate from the Remedial Contract with Sanborn Head.

1.02 RELATED SECTIONS

- A. Section 01 11 00 – Summary of Work.
- B. Section 01 31 00 – Project Management and Coordination.
- C. Section 01 33 00 – Submittal Procedures.
- D. Section 01 70 00 – Execution and Closeout Requirements.

1.03 REFERENCES

- A. Refer to Section 01 41 00 – Regulatory Requirements.

1.04 DEFINITIONS

- A. Refer to Section 01 42 00 – References.

1.05 SUBMITTALS

- A. Submittals from the survey shall include:
 - 1. Electronic files of the survey data in AutoCAD and PDF format.
 - 2. AutoCAD files shall include all linework and identifying information, and be accompanied by all supporting information in standard formats, including but not limited to:
 - a. Point files (.txt, .csv) of all survey points including Control.
 - b. LandXML file containing alignments, surfaces, sections, etc.
 - c. Any other supporting or referenced data (basemaps, imagery, shapefiles, etc.)

1.06 QUALITY ASSURANCE

- A. Not used.

PART 2 - PRODUCTS

2.01 MATERIALS

- A. Not Used

SECTION 02 21 00 – SURVEYS

PART 3 - Execution

3.01 LINES, GRADES AND LEVELS

- A. Contractor shall establish horizontal and vertical control at the Project site. Reference stakes and benchmarks shall be replaced at Contractor's expense if damaged or destroyed by construction operations.
- B. Contractor shall make all measurements and check all dimensions necessary for the proper construction of the Work in accordance with the Drawings and Technical Specifications. During the execution of the Work, Contractor shall make all necessary measurements to prevent misalignment of the Work and shall be responsible for accurate construction.

3.02 FIELD LAYOUT

- A. Contractor shall employ competent personnel to provide the surveying functions, to be directed by a Professional Engineer licensed in the State of New Hampshire or a Land Surveyor licensed in the State of New Hampshire, at no additional cost to Owner.
- B. Contractor shall safeguard all points, grade marks, and benchmarks established for the Work. Should any of the points be destroyed, the replacement will be at the cost of Contractor. Contractor shall assume the entire expense of rectifying work improperly constructed due to failure to maintain and protect such established points and marks.
- C. *Contractor shall provide an As-Built survey of all topographic and relevant site features within 14 days of final closeout. Survey must be representative of completed Work (shall not be done prior to completion nor long after).*

END OF SECTION

SECTION 02 61 13 – EXCAVATION AND HANDLING OF CONTAMINATED MATERIALS

PART 1 - GENERAL

1.01 SUMMARY

- A. Section includes requirements for handling of contaminated soil (including both hazardous and non-hazardous waste). Contractor shall furnish all labor, materials, tools, and equipment, and perform all operations necessary to manage the contaminated soil as described in this and other specification sections and as indicated on the Drawings and as specified in the October 2025 Analysis of Brownfields Cleanup Alternatives (ABCA) Update/ Remedial Action Plan (RAP) and December 5, 2025 Memorandum.
- B. The site contains soil with lead, arsenic, antimony, chromium, and select polycyclic aromatic hydrocarbons (PAHs) concentrations in excess of the New Hampshire Department of Environmental Services (NHDES) Soil Remediation Standards (SRS).
- C. The Work will be conducted in accordance with the 2025 ABCA Update/RAP prepared by Sanborn, Head & Associates, Inc. and approved by NHDES.
- D. The Contractor shall submit its proposed off-site permitted disposal facility(ies) for the various classifications of material described herein as part of its bid package.

1.02 RELATED SECTIONS

- A. Section 01 11 00 – Summary of Work.
- B. Section 01 33 00 – Submittal Procedures.
- C. Section 01 35 29.13 – Health, Safety, and Emergency Response Procedures for Contaminated Sites.
- D. Section 01 57 13 – Temporary Erosion and Sediment Control.
- E. Section 01 57 26 – Site Watering for Dust Control.
- F. Section 31 20 00 – Earth Moving.
- G. Drawings.

1.03 REFERENCES

- A. Refer to Section 01 41 00 – Regulatory Requirements.
- B. Contractor shall obtain, review, and be familiar with the following documents. These documents can be reviewed through the NHDES OneStop database under NHDES Site Number 199909015 (<https://www4.des.state.nh.us/DESONestop/SiteDocuments.aspx?SiteNumber=199909015>):
 1. “Removal Program After Action Report for the Woods Woolen Mill Site, Hillsborough, Hillsborough County, New Hampshire, 22 November 2021 through 2 September 2022”, prepared by Weston Solutions, Inc. for the U.S. Environmental Protection Agency, dated November 2022.
 2. “Analysis of Brownfields Cleanup Alternatives Update/ Remedial Action Plan Former Woods Woolen Mill Site, 23-25 West Mill Street, Hillsborough, NH 03244”, prepared by Sanborn, Head & Associates, Inc., dated October 2025.
 3. “Memorandum, Former Woods Woolen Mill, Pre-Construction Drilling Program Results, NHDES Site No. 199909015 “, prepared by Sanborn, Head & Associates, Inc., dated December 5, 2025.

SECTION 02 61 13 – EXCAVATION AND HANDLING OF CONTAMINATED MATERIALS

1.04 DEFINITIONS

- A. Refer to Section 01 42 00 – References.

1.05 SUBMITTALS

- A. Comply with the requirements and procedures of Section 01 33 00 - Submittal Procedures.

1.06 QUALITY ASSURANCE

- A. Not used.

1.07 CONTRACTOR RESPONSIBILITIES

- A. Contractor shall adhere to all regulations, specifications, and recognized standard practices related to the management of contaminated and potentially contaminated material during excavation and removal activities. Owner and Engineer will not be responsible at any time for Contractor's violation of pertinent Local, State, or Federal regulations or endangerment of construction workers, passers-by, or any others.
- B. Minimum precautions noted in this Section shall in no way relieve Contractor of his responsibility for implementing stricter health and safety precautions should they be warranted by the work.
- C. Contractor shall implement health and safety procedures designed to protect health, safety, public welfare, and the environment during the performance of all Work. Such procedures shall include, without limitation, the following:
 - 1. Measures to protect sensitive human populations from exposure to hazardous material;
 - 2. Measures that may be necessary to contain hazardous material during the performance of the Work, including:
 - a. Measures to control fugitive dust and other environmental media;
 - b. Measures to decontaminate vehicles and equipment to minimize the spread of contaminated soil from the Work area;
 - c. Measures to secure on-site excavations and temporary stockpiles of contaminated materials; and
 - d. Discontinuance of the Work where necessary to protect public health and safety.
- D. Contractor is required to notify all workers of the history of the site, its contaminants that may be present, and to be alert for evidence of contaminated soils. Engineer shall be notified of the presence of potentially hazardous conditions.
- E. The Contractor is responsible for construction, protection, and maintenance of on-site soil stockpiles through final disposal. Temporary stockpiling of soil at off-site locations and Lots 27 (NHDOT parcel) and 29 on-site are not allowed. Contractor shall stockpile material only in areas mutually agreed upon by Engineer and Contractor. Stockpiles shall be placed on at least 2 layers of 6-mil (0.006") polyethylene sheeting and covered by at least 1 layer of 6-mil polyethylene sheeting when not actively being added to.
- F. Contractor shall provide reasonable prior notice of schedule changes and shall cooperate with Engineer who will be present to observe and document excavation and handling of contaminated soil at the site.

SECTION 02 61 13 – EXCAVATION AND HANDLING OF CONTAMINATED MATERIALS

- G. Contractor shall allow free access for Engineer to collect samples from material proposed to be shipped off-site, or obtain additional samples and/or analyses, if necessary, to comply with the requirements of any in-state or out-of-state permitted landfill facility or in-state or out-of-state recycling or disposal facility that will be receiving material from the site at no additional cost to Owner or funding agency. Contractor shall not collect samples for laboratory analysis unless approved by Engineer.
- H. Contractor is responsible for providing documentation to track material from when and where it is excavated on the site and temporarily stockpiled, until it is accepted by, and disposed of, at an approved permitted disposal facility or facilities.
- I. Contractor is responsible for obtaining all required signatures for shipping documentation.
- J. Contractor is responsible for removal and proper disposal of all materials and equipment used during the course of this Work and for the cleanup of all site areas to the satisfaction of NHDES and Engineer.
- K. After the contaminated soil is hauled to the approved permitted disposal facility or facilities, Contractor shall provide copies of the final executed shipping forms and receipt logs (such as Weight Slips, Load Information Summary Sheets and Disposal Facility Receipt Logs). Contractor shall submit completed and executed forms to Engineer.

1.08 RESPONSIBILITIES OF OTHERS

- A. NHDES will retain the Engineer to observe the Work. Engineer shall observe excavation of contaminated soil and will conduct confirmatory sample collection. Such testing by Engineer will be performed on soil taken directly during excavation and/or from samples retrieved from stockpiles created and maintained by the Contractor. This testing is separate from the testing performed by Engineer to satisfy the permit requirements for testing type(s) and frequencies that may be required by disposal and/or recycling facilities.
- B. The Engineer will collect confirmatory samples from Excavation Area 1 – Former Mill Building Foundation following removal of the contaminated soil beneath the granular fill cover material placed by the USEPA Removal Program (if soil remains over bedrock after the excavation is complete). Note that contaminated soil in Excavation Area 1 will only be excavated to the subgrade elevation required for the floodplain restoration work.
- C. The Engineer will collect confirmatory samples from Excavation Areas 2 & 3 – Areas Northeast of the Former Dye House, and Excavation Area 4 – New Embankment to confirm that the extent and/or depth of the excavations are satisfactory.
- D. In addition to the confirmatory soil samples that will be collected and submitted for laboratory analysis by the Engineer, soil will be field-screened by the Engineer approximately every 50 feet along the sidewalls and base of Excavation Area 4 – New Embankment using an X-ray Fluorescence (XRF) analyzer for the potential presence of lead during excavation to confirm that soils remaining in-situ do not exceed the NHDES SRS for lead (400 mg/kg). Additional excavation may be required by the Contractor at the discretion of the Engineer if the XRF screening indicates exceedances of the applicable criteria.
- E. For material to be shipped off-site, the Owner will sign any Waste Manifest forms. The Contractor shall allow at least two weeks for obtaining all required signatures from the Authorized Parties prior to shipping soil and/or other contaminated materials from the Site.

1.09 PERMITS, CODES, POLICIES, AND SAFETY REGULATIONS

- A. All work shall conform to the Drawings and Technical Specifications and shall comply with applicable codes, permits, and regulations.

SECTION 02 61 13 – EXCAVATION AND HANDLING OF CONTAMINATED MATERIALS

- B. Comply with all rules, regulations, laws, permits and ordinances of all authorities having jurisdiction including, but not limited to: NHDES, USEPA, and the Town of Hillsborough, New Hampshire.
- C. Comply with the requirements of the Occupational Safety and Health Administration (OSHA) and the United States Department of Labor.

1.10 SOIL CLASSIFICATION SYSTEM

- A. Excavated materials designated for on-site reuse and off-site disposal will be classified as follows:
 - 1. **On-Site Granular Capping Material:** Consists of the granular fill cover soils within Excavation Area 1 – Former Mill Building Foundation that were placed on top of geotextile fabric by USEPA during their 2022 Removals Program that may be used as reuse material on-site (e.g., capping of Warehouse #2, portions of the Northeast Former Dye House Cap, backfilling). Material was previously tested by Engineer and is suitable for reuse as capping material elsewhere on-site.
 - 2. **Contaminated Soils:**
 - a. **Soils to be Capped On-Site:** Consists of the contaminated soils located in the Former Warehouse Building #2 Cap Area and Former Dye House Cap Area.
 - b. **Soils Designated for Off-Site Disposal:** Consists of the contaminated soils that remain within Excavation Area 1 – Former Mill Building Foundation beneath the granular fill cover material and geotextile marker fabric placed by USEPA Removal Program in 2022, the contaminated soil to be excavated from Excavation Areas 2 and 3 – Area Northeast of the Former Dye House, Excavation Area 4 – New Embankment, and the gravel used in the construction of the decontamination pad to be removed at the end of the Work. Materials excavated from these locations will be managed and disposed of off-site either as non-hazardous or hazardous waste based on waste characterization sampling to be performed by the Engineer. It is anticipated that the used gravel from the decontamination pad will be sent off-site with the final shipment of non-hazardous waste.
 - 3. **Rocks and Rubble in Excavation Area 1 – Former Mill Building Foundation:** Consists of concrete/ foundation rubble, and rocks larger than 9 inches in diameter which are encountered in Excavation Area 1 – Former Mill Building Foundation. Rocks larger than 9-inches in diameter shall be used to stabilize/construct the northernmost portion of the Northeast Former Dye House Cap Area, as shown on the Drawings. Rubble and excess rocks that cannot be reused on-site will need to be shipped off-site for disposal at a facility to be approved by the Engineer.

PART 2 - PRODUCTS

2.01 MATERIALS

- A. Polyethylene barrier
 - 1. Polyethylene barrier for use in protecting stockpiles from spreading contamination shall be minimum 6-mil (0.006 inches) thick. At least two (2) layers of polyethylene shall be used beneath stockpiles to protect the ground surface. At least one (1) layer of 6-mil polyethylene will be used to cover contaminated soil stockpiles at all times except when modifying stockpiles. Cover will be secured to avoid being blown off.
- B. Personal Protective Equipment
 - 1. Refer to Section 01 35 29.13 – Health, Safety, and Emergency Response Procedures for Contaminated Sites.

SECTION 02 61 13 – EXCAVATION AND HANDLING OF CONTAMINATED MATERIALS

PART 3 - EXECUTION

3.01 EXCAVATING CONTAMINATED SOIL

- A. The Contractor shall excavate to the depths and extent specified on the Drawings or deeper/ beyond the extents if indicated by the Engineer.

3.02 STOCKPILING EXCAVATED SOIL AND RUBBLE

- A. If needed, stockpiles of excavated soil and rubble shall be a maximum of 8-feet high unless alternate stockpile configurations are approved by Engineer.
- B. Contractor is responsible for the construction, protection, and maintenance of temporary stockpiles.

3.03 STOCKPILE CRITERIA

- A. Contractor is responsible for the construction, protection, and maintenance of all temporary stockpiles of soil for on-site reuse and off-site disposal during construction and through testing and final disposal.
- B. Prior to the start of excavation, work areas shall be prepared for the temporary stockpiling of material. Soil stockpiles are needed for excavated soil assigned for follow-up testing, or, because of other logistical reasons, the soil cannot immediately be reused or disposed of off-site. The following minimum stockpile criteria apply to all stockpiled materials:
 - 1. Stockpile areas shall be graded such that stormwater run-on is diverted from stockpiled soil; clean soil shall be placed around the base of the stockpile.
 - 2. Access shall be restricted and shall be visibly marked with appropriate warning signs of potential hazards.
 - 3. The first lift of a stockpile shall be placed on a minimum of two layers of 6-mil thick (0.006") or one layer of 20-mil thick (0.020") polyethylene barrier over existing soil.
 - 4. The size of the individual stockpiles of material designated for off-site disposal shall be limited such that no individual stockpile is higher than 8 feet. Total dimensions and locations of the stockpile areas shall be at the discretion and approval of Engineer.
- C. The transfer of materials to the stockpile areas shall be performed by Contractor in such a manner as to prevent the spread of contaminated or potentially contaminated materials across the site and to minimize the mixing of materials from different areas of the site. The stockpiles shall not be moved or rearranged without the approval of the Engineer.
- D. Stockpiled soils shall be covered prior to the onset of inclement weather, at the end of each work day, and when not actively being used, with a minimum 6-mil thick (0.006") polyethylene cover overlapped and weighted to form a continuous waterproof barrier over the soil. The cover shall be maintained by Contractor throughout the stockpile period to prevent water from entering the soil and to prevent blowing dust.
- E. Excavation and soil handling shall be performed in a manner which limits mixing of materials with different levels of contamination to the highest degree possible. Disposal of soil that is contaminated as a result of Contractor's careless, unauthorized procedures for excavation or handling and stockpiling shall be at his own expense.
- F. All stockpiles shall be located within Map 25, Lot 28 unless otherwise approved by Engineer.

SECTION 02 61 13 – EXCAVATION AND HANDLING OF CONTAMINATED MATERIALS

- G. No re-handling of stockpiled soil shall be performed unless observed by Engineer. No material shall be removed from the site without approval of Engineer.

3.04 WEIGHT MEASUREMENT

- A. Contractor shall provide certified tare and gross weight slips for each load received at the accepted facility, which shall be attached to a copy of each manifest

3.05 DISPOSAL OF MATERIALS

- A. All material designated for off-site disposal shall be transported to an off-site location via a tracking form appropriate for the material classification in accordance with the laws of the appropriate local, state, and federal authorities. Contractor shall obtain approval for the proposed disposal facility or facilities prior to disposal.
- B. No stockpiled material shall be removed for off-site disposal until the results of chemical analyses have been received and the materials have been properly characterized.
- C. The Owner will be designated as generator for all material transported off-site, in accordance with these specifications and with all applicable local, state, and federal requirements.
- D. All soil to be transported off-site shall be loaded under the direction of the Contractor into properly licensed and permitted vehicles and transported directly to the selected facility.
- E. Given the limited availability of space on-site, where feasible, soil designated for off-site disposal shall be direct loaded into properly licensed and permitted vehicles.

3.06 DECONTAMINATION OF EQUIPMENT

- A. Contractor's tools and equipment that were in contact with contaminated soil shall be decontaminated on the site prior to being removed from the site using methods approved by the Engineer. This shall include all tools, heavy equipment, excavators, and loaders used during excavation, stockpiling, and handling of contaminated material.
- B. The Contractor shall decontaminate trucks and equipment that have come into contact with contaminated soil before driving onto the staging areas, access roads, or construction entrance.
- C. If soil or gravel from the staging areas, access roads, or construction entrance come into contact with contaminated soil, then the surficial material shall be sampled at the Contractor's expense and disposed of off-Site at an approved permitted disposal facility at the Contractor's expense.
- D. Decontamination shall take place on a decontamination pad constructed by the Contractor using materials approved by the Engineer.
- E. Decontamination of equipment shall consist at a minimum of jet washing and steam cleaning to effectively remove all contaminated soil, residues, and other debris adhering to the equipment and tools.
- F. The Contractor shall not allow equipment to leave the site with water leaking or mud dripping from or caked to the equipment.
- G. The Contractor shall conduct decontamination of haul trucks on the site after each truck has hauled its last load of site soil and before it goes to another site or project.

SECTION 02 61 13 – EXCAVATION AND HANDLING OF CONTAMINATED MATERIALS

- H. Decontamination water shall either be allowed to infiltrate into the ground surface through the decontamination pad, or shall be stored in a fractionation tank or other suitable container for temporary storage. Containerized decontamination water shall be recharged to the ground surface within the cap areas prior to construction of the caps.

END OF SECTION

SECTION 31 11 00 – CLEARING AND GRUBBING

PART 1 - GENERAL

1.01 SUMMARY

- A. Section includes requirements for grubbing, removing, and disposing of all vegetation and debris including stumps, branches, and shrubs, within the limits of work shown on the Drawings or specified below.
- B. Portions of this specification shown in *italics* were prepared by the Hydraulic Engineer (Streamworks, PLLC) for floodplain restoration work. That work is covered by the Restoration Contract being led by Streamworks PLLC and is separate from the Remedial Contract with Sanborn Head.

1.02 RELATED SECTIONS

- A. Section 01 11 00 – Summary of Work.
- B. Section 01 57 13 – Temporary Erosion and Sediment Control.

1.03 REFERENCES

- A. Refer to Section 01 41 00 – Regulatory Requirements.

1.04 DEFINITIONS

- A. Refer to Section 01 42 00 – References.

1.05 SUBMITTALS

- A. Comply with the requirements and procedures of Section 01 33 00 – Submittal Procedures.
- B. Contractor shall submit its proposed off-site permitted disposal facility(ies) for any stumps, large roots, branches, other wood, brush, weeds, grass and other perishable material and invasive species (e.g., Japanese Knotweed) resulting from the clearing and grubbing operations as part of its bid package.

1.06 QUALITY ASSURANCE

- A. The Contractor shall take care in performing clearing and grubbing operations to remove only those materials designated for removal. Any material removed by the Contractor that is not designated for removal shall be replaced solely at the Contractor's expense.
- B. Contractor shall take care when performing clearing and grubbing to avoid any damage to existing infrastructure, especially at existing retaining walls. Damage incurred to existing site features during clearing and grubbing will be restored at the expense of the Contractor.
- C. Contractor shall be responsible for the full and complete removal of all invasive species within the work limits as defined for the project. Contractor shall take care to segregate removed invasive species from other clearing and grubbing wastes to avoid cross-contamination. In addition, Contractor shall remove invasive species in accordance with Best Management Practices as described in the New Hampshire Department of Transportation's Env 1, Manual 1 "Best Management Practices for the Control of Invasive and Noxious Plant Species", dated 2018 (https://www.dot.nh.gov/sites/g/files/ehbemt811/files/inline-documents/final-env-1-manual-1-invasive-species_0.pdf).

SECTION 31 11 00 – CLEARING AND GRUBBING

PART 2 - PRODUCTS

2.01 MATERIALS

- A. Not Used

PART 3 - EXECUTION

3.01 CONSTRUCTION REQUIREMENTS

- A. Every reasonable effort shall be made to minimize the area required for performing the proposed work. Following construction layout of the project by the Contractor, the Engineer shall designate trees, stumps, shrubs, and plants to be removed as well as those to remain in place.
- B. Burning of brush will not be permitted.
- C. Contractor shall install erosion and sediment controls in areas topographically below areas which will be disturbed and shall perform the Work in a manner that limits erosion and sedimentation. Contractor shall cease work and install additional erosion and sediment control measures if ordered by Engineer or Owner.
- D. Contractor shall take care to minimize soil disturbance and dust creation during clearing and grubbing activities. Contractor shall cease work and implement dust control measures if ordered by Engineer or Owner.
- E. Contractor shall perform the work of grubbing to include the removal of brush, stumps, and large roots to a depth of not less than two feet below the cut surface unless otherwise directed by Engineer. Contractor shall take care to shake loose topsoil from root systems to remain in original location and remove as much soil as possible prior to off-site disposal.
- F. Stumps, large roots, branches, other wood, brush, weeds, grass, perishable material, and invasive species (e.g., Japanese Knotweed) resulting from the clearing and grubbing operations shall be disposed of at an off-site permitted disposal facility approved by the Engineer.
- G. *Hydraulic Engineer will flag, or instruct in the field, trees to remain as well as any trees/plants to be stockpiled and replanted for Restoration work.*
- H. *Native, non-invasive species may be chipped and reused onsite for slope stabilization and erosion control, per Section 01 57 13.*
- I. *Clearing trees and shrubs growing in and immediately adjacent to retaining walls shall be removed by hand, cut as low to the ground as possible leaving the root ball intact so damage to walls is avoided. Do not rip plants out in these locations.*
- J. *Contractor shall be responsible for the correct identification and complete removal of all invasive species within the project work limits. Invasives growing after final completion of construction, determined to be from preconstruction sources shall be removed completely and disposed of at the expense of the Contractor.*

END OF SECTION

SECTION 31 20 00 – EARTH MOVING

PART 1 - GENERAL

1.01 SUMMARY

- A. Contractor shall furnish all labor, materials, equipment, and incidentals necessary to perform the earthwork required to complete the Work shown on the Drawings and specified herein, including, but not limited to, excavating, segregating, soil placement, compaction, and grading.
- B. Contractor shall work with the Engineer and Hydraulic Engineer and provide assistance as needed so that the required quality assurance sampling and testing may be performed. Quality assurance activities shall be considered germane to the work and not be a cause for scheduling delays. Characterization and disposal analysis will be completed by Engineer as discussed in Section 02 61 13 – Excavation and Handling of Contaminated Materials.
- C. Contractor is responsible for the satisfactory completion of the Work. If a subsequent test shows defects in materials or workmanship, Contractor, at their own expense, shall make the necessary repairs and replacements to the satisfaction of Engineer, Hydraulic Engineer, and Owner.
- D. Portions of this specification shown in *italics* were prepared by the Hydraulic Engineer (Streamworks, PLLC) for floodplain restoration work. That work is covered by the Restoration Contract being led by Streamworks PLLC and is separate from the Remedial Contract with Sanborn Head.

1.02 RELATED SECTIONS

- A. Section 01 11 00 – Summary of Work.
- B. Section 01 57 13 – Temporary Erosion and Sedimentation Control.
- C. Section 02 61 13 – Excavation and Handling of Contaminated Materials.
- D. Section 31 32 00 – Soil Stabilization
- E. Section 32 91 19.13 – Topsoil Placement and Grading.
- F. Section 32 92 19.16 – Hydraulic Seeding.
- G. Drawings.

1.03 REFERENCES

- A. Refer to Section 01 41 00 – Regulatory Requirements.

1.04 DEFINITIONS

- A. Refer to Section 01 42 00 – References.

1.05 SUBMITTALS

- A. Comply with the requirements and procedures of Section 01 33 00 – Submittal Procedures.

1.06 QUALITY ASSURANCE

- A. Not used.

SECTION 31 20 00 – EARTH MOVING

1.07 SOIL TESTING AND CONSTRUCTION MONITORING

- A. During excavation and prior to placement of backfill, the Engineer will collect soil samples from select excavation sidewalls and base for laboratory analysis. The Engineer shall also field screen soil on the base and sidewalls for lead during excavation at select excavation areas. The Contractor shall cooperate fully with the Engineer in collecting the soil samples, including providing the services of the excavator and other equipment to obtain the soil samples. The Owner will pay for the sample analysis.
- B. The Contractor will cooperate fully with the Engineer, as the Engineer will have the authority to guide Contractor to the limits of excavation as part of Remediation Work.
- C. The Contractor will cooperate fully with the Hydraulic Engineer, as the Hydraulic Engineer will have the authority to guide the Contractor to the limits of excavation as part of the Restoration Work per adaptive management permission granted by the Wetland permit.
- D. During fill placement, Engineer may select areas for testing the degree of compaction obtained. Contractor shall cooperate fully in obtaining the information desired and shall allow Engineer sufficient time to make necessary observations and tests.
- E. Payment for compaction testing will be made by Owner. If test results are unsatisfactory, all costs involved in correcting deficiencies in compacted materials to the satisfaction of Engineer and Owner will be borne by Contractor.
- F. Soil layer thickness measurements shall be made normal to the slope, not vertical.
- G. Earth Moving encompassed by Remediation efforts generally include excavation and off-Site disposal of contaminated soils to the stated subgrade depth in the Excavated Areas; backfilling and capping at the former dye house (northern terminus of Restoration area) and former Warehouse Building #2; backfilling of the remaining Excavation Areas; and staging/stockpiling of materials.
- H. *Excavation and Earth Moving encompassed by Restoration efforts generally include: removal of concrete and bedrock to subgrade elevation where found within the Restoration limits; furnishing equipment, labor, and materials appropriate for concrete and bedrock removal (no blasting allowed); backfilling with clean, imported material to achieve final grade; regrading the berm and constructing access road to Restoration area following Remediation efforts, as necessary, work on the Riverside and Upland retaining walls; and staging/stockpiling of materials.*

PART 2 - PRODUCTS

2.01 GENERAL

- A. All backfill and fill materials, unless otherwise specified, shall consist of clean, well-graded granular soil from within Excavation Area 1 – Former Mill Building Foundation Area. If material from Excavation Area 1 is not deemed suitable by the Engineer for reuse on-Site, the Contractor shall provide an off-site fill material that meets the criteria for Granular Fill in Section 2.03.
- B. The maximum particle size shall be no larger than two-thirds the lift thickness.
- C. All required fill materials shall be substantially free from organic materials, wood, trash, and other objectionable materials which may be compressible or which cannot be properly compacted. Granular Fill materials shall not contain stone blocks, asphaltic pavement, broken concrete, masonry rubble, or other similar materials. It shall have physical properties such that it can be readily spread and compacted to the specified permeability and/or density. Snow, ice, and frozen soil shall not be permitted. Do not work with or place wet, saturated material.

SECTION 31 20 00 – EARTH MOVING

2.02 ON-SITE MATERIALS

- A. The granular fill cover material to be reused from Excavation Area 1, as shown on the Drawings, shall be used as backfill and capping material for proposed capped areas outside of the Restoration Area, unless found to be unsuitable by the Engineer or unless otherwise specified.
- B. *No clean fill from onsite shall be used as backfill for Restoration work. Select other materials such as large rock rubble may be reused or buried onsite if appropriate, as designated by the Hydraulic Engineer. All unsuitable material excavated as part of Restoration efforts must be disposed of properly.*
- C. *Rock rubble (no concrete) material may be buried onsite where possible.*

2.03 GRANULAR FILL

- A. Granular Fill, unless otherwise noted, shall be obtained on-site from the cover material placed on top of geotextile fabric by the USEPA Removals Program in Excavation Area 1 – Former Mill Building Foundation Area.
- B. Granular Fill materials shall not contain stone blocks, asphaltic pavement, broken concrete, masonry rubble, and other deleterious or organic matter.
- C. If on-site material is deemed unsuitable for reuse on-Site, the Contractor shall provide alternative Granular Fill which shall have a particle-size distribution in accordance with ASTM D6913 within the following limits:

Sieve Size	Percent Finer by Weight
4-inch	100
No. 10	25 – 95
No. 40	15 – 75
No. 200	0 – 10

2.04 CRUSHED GRAVEL

- A. Crushed Gravel will be used to construct the decontamination pad and access road as well as the stabilized construction entrance.
- B. Crushed Gravel shall be free from ice, snow, roots, sod, rubbish, and other deleterious or organic matter.
- C. Crushed Gravel shall meet the particle-size distribution (ASTM D6913) requirements of NHDOT 304.3 Crushed Gravel as specified in Section 304 of the New Hampshire Department of Transportation, Standard Specifications for Road and Bridge Construction, as listed below:

Sieve Size	Percent Finer by Weight
3-inch	100
2-inch	95 - 100
1-inch	55 - 85
No. 4	27 - 52
No. 200	0 - 12*

*Based on the fraction passing the No. 4 sieve

- D. *Crushed gravel for stabilized construction entrance shall consist of 4" stone underlain by a geogrid or non-woven geotextile.*

SECTION 31 20 00 – EARTH MOVING

- E. *Graded filter material shall be used where necessary to fill voids in subgrade material to prevent topsoil from eroding and collapsing into the voids.*
- F. *Graded filter material shall consist of 3 to 9 inch angular rock sprinkled atop void areas, then by 0.5 to 2 inch angular rock sprinkled on top.*

2.05 TOPSOIL

- A. Topsoil shall be placed to a minimum thickness of 6 inches in the soil cap area(s), as directed by the Engineer.
- B. *Topsoil shall be placed to a minimum thickness of 18 inches in the Floodplain Restoration areas, as shown on the plans or as directed by the Hydraulic Engineer.*
- C. Refer to Section 32 91 19.13 – Topsoil Placement and Grading for Product specifications.
- D. Contractor shall obtain topsoil from a vendor and location approved by the Engineer and Owner.

2.06 GEOTEXTILE MARKER FABRIC

- A. Geotextile shall be installed above the subgrade (i.e., contaminated material) and below the clean soil cap as shown on the Drawings. The separator geotextile shall be a non-woven polypropylene fabric meeting the following minimum values:

PROPERTY	MINIMUM REQUIREMENT	
	ELONGATION < 50%	ELONGATION ≥ 50%
Mass/Unit Area (oz/yd ²)	6	6
Grab Strength (lbs)	270	180
Puncture Strength (lbs)	100	75
Trapezoidal Tear (lbs)	100	75
Apparent Opening Size	70 - 100 sieve	70 - 100 sieve

PART 3 - EXECUTION

3.01 PROTECTION OF EXISTING FACILITIES AND UNDERGROUND UTILITIES

- A. Contractor shall at all times during construction protect landscaping structures, retaining walls, paving, and other features outside of the limits of the Work. Contractor shall install barriers or grade the area surrounding the excavation to prevent the flow of surface water into the excavations. Contractor shall provide fences, barricades or any other means necessary to protect the public from entering the work area or open excavations.
- B. Underground utilities may exist in the work areas. Contractor shall review the locations of underground utilities with the Engineer and Owner before beginning excavation or other intrusive activities. Contractor shall review any available drawings indicating utility locations. Contractor shall contact DigSafe and obtain a Digsafe number prior to beginning any intrusive work at the site.
- C. Contractor is responsible for any damage to utilities marked by DigSafe, shown on Drawings, marked by Contractor's private utility locator, or otherwise believed to be present based on Contractor's field observations or discussions with Owner and/or Engineer. Any such utilities damaged by performance of the work shall be repaired by Contractor at no additional cost. Contractor shall repair all damaged utilities to the satisfaction of Owner and Engineer.

SECTION 31 20 00 – EARTH MOVING

- D. Contractor shall at all times during construction provide and maintain proper equipment and facilities to remove all water entering the construction area as part of this Work. This may include providing barriers to prevent surface water from flowing into excavations, and providing temporary berms, swales, and other structures as needed to redirect storm water. See Section 01 57 13 – Temporary Erosion and Sediment Control.
- E. Contractor shall plan and perform its operations to prevent damage to existing structures, safeguard people and property, minimize disruptions to site traffic, protect the structures to be installed, and provide safe working conditions in compliance with local safety regulations and provisions of the Occupational Safety and Health Act (OSHA).
- F. Contractor shall establish a temporary construction fence with a locking gate or use the existing fence and locking gate to protect the public from entering the work area. See Section 01 50 00 – Temporary Facilities and Control.
- G. Contractor shall take all necessary precautions to preclude the accidental discharge of fuel, oil, etc. in order to prevent adverse effects on surface water and groundwater quality. In the event of an accidental spill, the Owner and Engineer shall be notified immediately. All free liquids shall be cleaned up and all contaminated soil shall be excavated and disposed of properly by the Contractor at the Contractor's expense. Contractor shall install barriers or grade the area surrounding the excavation to prevent the flow of surface water into excavations. Contractor shall provide fences, barricades or any other means necessary to protect the public from entering the work area or open excavations.
- H. *Contractor shall not excavate down to the toe of the existing Upland retaining wall, which is assumed to be somewhere near elevation 572-574 feet NAVD88. Remove only enough material so backfill may be placed atop a toe protection slope as shown in the Drawings.*

3.02 GENERAL EXCAVATION BELOW GRADE

- A. Excavations shall be made to the elevations and dimensions shown on the Drawings. Excavate sufficient material to provide suitable room for construction providing bracing and support as required. The bottom of the excavations shall be rendered firm and dry and in all respects acceptable to the Engineer.
- B. Remove, by pumping or other means, water accumulated in excavations to maintain a dry and stable subgrade until earthwork operations are complete. All dewatering shall be performed at the Contractor's cost. Coordinate with Section 31 23 19 – Dewatering.
- C. Where the soil subgrade is softened, eroded, or otherwise disturbed by flooding, exposure during unfavorable weather, or other causes, it shall be over-excavated and replaced with suitable material at no cost to the Owner.
- D. When the required excavation depth and horizontal extent is achieved, the Contractor shall notify the Engineer that the excavation is ready for inspection and sampling. If, in the opinion of the Engineer, the material still contains lead in concentrations above the cleanup level, then the Contractor shall increase the size of the excavation as directed by the Engineer.
- E. The Contractor shall exercise care to preserve the material below and beyond the lines of excavation. If the bottom of an excavation is extended below the limits shown on the Drawings or specified or directed by the Engineer, it shall be filled and compacted in accordance with these specifications.
- F. Where deeper than three feet, the Contractor shall slope the excavation as indicated in the Drawings. All soil from the sloped cut shall stockpiled separately and used to backfill the excavation.
- G. *Excavation below grade for Remediation efforts shall be limited to contaminated material. Excavation below grade for Restoration efforts shall remove all remaining materials – in particular large rock rubble, concrete, and bedrock – down to subgrade elevation.*

SECTION 31 20 00 – EARTH MOVING

- H. *Excavation of solid materials (concrete including former Boiler House foundation slab and bedrock) shall require appropriate equipment – an excavator with a hammer attachment, for example – and blasting is not allowed. Concrete is evident and protruding from the existing surface. Bedrock is prevalent at the site and surrounding lands; borings have indicated its presence within the excavation limits, though Contractor shall be prepared for bedrock extents to be variable.*
- I. *Excavation of Restoration (non-contaminated) materials shall be disposed of properly at pre-approved facilities and is not anticipated to need to be treated as contaminated waste. If contamination is identified during construction, Contractor will work with the Engineer to coordinate proper off-site disposal.*
- J. *Where discovered, remove unnatural material such as metal debris or disconnected drain pipes so long as the material is easily removable. This applies primarily to the southern section of the Restoration area (at the former water wheel) where debris is visible. Dispose of this material appropriately at pre-approved facilities.*
- K. *All excavation shall be done ‘in the dry,’ dewatered as necessary. Dewatering is expected to be limited, though likely necessary at the southern end of the Restoration area near the former water wheel. Coordinate with Section 31 23 19 – Dewatering.*

3.03 SUBGRADE PREPARATION – GENERAL

- A. Prior to fill placement, the subgrade should be compact, dry, and free from debris, ice, and snow. Fill shall not be placed over frozen soil unless otherwise approved by Engineer.
- B. Contractor shall place geotextile membrane fabric on subgrade (i.e., contaminated material) prior to clean fill placement. Placement of the membrane shall be done in such a manner as to minimize disturbance of the underlying ground. Deterioration of the subgrade prior to initial fill placement shall be the responsibility of Contractor and shall be repaired at Contractor's expense.
- C. All subgrades will be observed by Engineer prior to fill placement. Sufficient time must be given to Engineer to inspect and perform any necessary tests on the subgrade.
- D. *When excavation to subgrade elevation has been completed, some lands may consist of material with large voids – particularly where large rock rubble is found. When subgrade surfaces contain voids, a graded filter shall be used to prevent topsoil from eroding and collapsing into the voids.*
- E. *Graded filter shall consist first of larger, cobble-sized rock followed by smaller, gravel-sized rock with the goal being a gradual filling of all voids.*
- F. *When graded filter has been placed, lay a thin layer (approximately 2 inches) of topsoil on top and gently – ensuring no material erodes onto adjacent lands or into the river – wash the material into the filter. Repeat this as necessary until topsoil no longer washes into the filter.*
- G. *Graded filter shall be placed no higher than 4 inches above the final subgrade elevation.*

3.04 BACKFILLING – GENERAL

- A. All fill shall be placed “in the dry.” The fill areas shall be graded to drain and provide a smooth surface, which will readily shed water.
- B. Fill containing ice, snow, frozen soil, large rocks, or other deleterious material shall not be placed.
- C. Fill placement shall not be allowed during weather conditions that do not allow for proper moisture and density controls.
- D. Fill that is too wet for proper compaction shall be disced, harrowed, rototilled, or otherwise dried to a proper moisture content for compaction to the required density.

SECTION 31 20 00 – EARTH MOVING

- E. Fill that is too dry for proper compaction shall receive water uniformly applied over the surface of the loose layer. Compaction shall not be performed until the moisture content of the fill material is uniform. Sufficient water shall be added to allow for compaction to the required density at the required moisture content.
- F. The Engineer will observe construction and perform moisture content, particle size, and compaction tests at a frequency and at locations selected by the Engineer. Where tests indicate that fill does not conform to the specified compaction, the Contractor shall remove and recompact the fill to the specified density without additional cost to the Owner.
- G. The Engineer's presence does not include supervision or direction of the actual work by the Contractor, his employees, or agents. Neither the presence of the Engineer nor any observations and testing performed by him shall excuse the Contractor from defects discovered in their work.
- H. *Non-contaminated material (primarily rock rubble) may be buried onsite (at the Upland retaining wall toe slope or at the southern Restoration terminus, for example). When burying material which creates voids, a graded filter must be placed atop first so soil backfill does not erode and collapse (see 3.03 above).*

3.05 FILL PLACEMENT – RELOCATION OF ON-SITE SOIL

- A. The Contractor shall place on-site soil from Excavation Areas 3 and 4 – Areas Northeast of the Former Dye House and Excavation Area 5 – Embankment in loose lifts, not to exceed twelve (12) inches in the Former Warehouse Building #2 Cap Area. The maximum thickness may be less depending on the Contractor's equipment and amount of material available from the excavations. The maximum in-place compacted thickness for the placed soils shall not be more than twelve (12) inches.
- B. The soils shall be compacted with at least four (4) passes of a 10,000-pound vibratory, smooth-drum roller.

3.06 FILL PLACEMENT – SOIL CAP AND EXCAVATION AREAS

- A. The Contractor shall place the Granular Fill in loose lifts not exceeding nine (9) inches. The maximum thickness may be less depending on the Contractor's equipment and depth of the excavation. The minimum in-place compacted thickness for the soil caps shall be not less than twelve (12) inches for the Granular Fill.
- B. Upon approval by the Engineer, the cap for the Former Dye House Cap Area may be constructed using rubble/boulders from Excavation Area 1 – Former Mill Building Foundation Area. If rubble/boulders are used as capping material, the excavator bucket shall be used to compact the cap material.
- C. The Contractor shall use equipment appropriate for spreading the fill in a uniform layer across the lift.
- D. The Contractor shall compact the Granular Fill with at least four (4) passes of a 10,000-pound vibratory, smooth-drum roller. If 10,000-pound vibratory, smooth-drum roller cannot be practically used due to the small size and depth of an excavation, a vibratory plate compactor may be used.

3.07 FILL COMPACTION CRITERIA

- A. The Contractor shall compact each lift of fill sufficiently to destroy all clods and knead the soil mass together, producing a uniform, homogeneous mass free of all defects, cracks and fissures.
- B. Granular Fill placed shall be compacted to a density no less than 90% of the maximum dry density and at a moisture content within 2% of the optimum moisture content as determined by ASTM D698.

SECTION 31 20 00 – EARTH MOVING

3.08 FILL PLACEMENT – RESTORATION LIMITS

This describes fill placement within the Restoration limits except where fill has been placed and set to final grade as part of Remediation efforts (primarily the northern terminus of the Restoration work).

- A. *Contractor shall first ensure all concrete and bedrock has been removed down to desired subgrade.*
- B. *Place any existing material to be buried into appropriate locations, when necessary.*
- C. *Backfill the Restoration area to final grade with clean, imported topsoil.*
- D. *Topsoil shall be free from invasive species, without clumps and rock/debris larger than 3 inches, and be clean, imported fill.*
- E. *Do not over-compact topsoil, compact in 4-6 inch lifts using the excavator bucket or tracks.*
- F. *Set topsoil elevation between 0 to 2 inches above final grade to allow for settling.*
- G. *At the toe of the Upland retaining wall, ensure base of wall is never exposed. Construct a toe slope protection at 1:1 to 1:1.5 slope as indicated in the Drawings.*

3.09 EARTH MOVING – RETAINING WALLS

- A. *Refer to the Restoration Drawings for further instructions.*
- B. *Remove and rebuild the Riverside retaining wall to an elevation of 574.0' NAVD88. Perform this work cautiously to avoid damage to the wall. An excavator with a thumb is recommended.*
- C. *During Riverside wall work, construct a temporary path made from 4 inch crushed stone, similar to the construction of the Construction Access, underlain with a heavy weight non-woven geotextile (9 oz/sy or greater) or a geogrid.*
- D. *Remove/restore/rebuild the Upland retaining wall by chinking voids with materials recycled from onsite. Mortar material and voids together.*
- E. *Stockpile materials to be reused and/or disposed of for use in retaining wall construction or as fill.*

END OF SECTION

SECTION 31 23 19 – DEWATERING

PART 1 - GENERAL

1.01 SUMMARY

- A. Dewatering is required wherever excavation or work must be performed where water has pooled. At the site this is anticipated primarily at the south end of the project where water from the river enters during higher stages and cannot get back out, though will be required elsewhere if groundwater or runoff enters excavated lands. Dewatering applies to water which has not been in contact with contaminated soils, and will be permitted under the Wetland permit. Work, in general, shall include:
 - 1. Furnish all labor, materials, tools, and equipment, and perform all operations necessary for dewatering as indicated on the Drawings and as specified herein.
 - 2. Design of the entire temporary dewatering system and make whatever modifications and/or additions to the system as may be required for the system to fulfill its requirements.
 - 3. Provide filter materials and/or other structures needed to treat pumped water. Pumped water must be filtered until clear before being released.
 - 4. Provide system monitoring and maintenance by someone skilled in the operation, maintenance, and replacement of system components as well as any other equipment and work required by the Hydraulic Engineer to maintain the excavation dry. Some responsible person shall continuously monitor the dewatering and surface water central systems, until the Contractor has received approval from the Hydraulic Engineer that dewatering may be discontinued
- B. This specification was prepared by the Hydraulic Engineer (Streamworks, PLLC) for floodplain restoration work, which is covered by the Restoration Contract being led by Streamworks PLLC and is separate from the Remedial Contract with Sanborn Head.
- C.

1.02 RELATED SECTIONS

- A. Section 01 11 00 – Summary of Work.
- B. Section 01 33 00 – Submittal Procedures.
- C. Section 01 57 13 – Temporary Erosion and Sedimentation Controls.
- D. Section 01 70 00 – Execution and Closeout Requirements.

1.03 REFERENCES

- A. Not used.

1.04 DEFINITIONS

- A. Refer to Section 01 42 00 – References.

1.05 SUBMITTALS

- A. Submittals shall include:
 - 1. Comply with the requirements and procedures of Section 01 33 00 – Submittal Procedures.
 - 2. Refer to Section 01 33 00 – Submittal Procedures for a listing of submittals required under this Section.

SECTION 31 23 19 – DEWATERING

1.06 QUALITY ASSURANCE

- A. Products must be used according to manufacturer's specifications.
- B. No untreated water may enter the river.
- C. Filtered water must not be returned to lands containing contaminated soils.
- D. Water must be treated until clean.
- E. Treated water must not cause erosion to any land nor be allowed to pond elsewhere onsite.
- F. Trapped material shall be disposed of appropriately.
- G. Dewatering must be designed and implemented to avoid impacts to the site and surrounding lands to the maximum extent practicable.
- H. Maintenance and inspection of equipment must occur at the beginning and end of each day. Any issue must be fixed immediately before resuming work.

PART 2 - PRODUCTS

2.01 MATERIALS

- A. Products and equipment shall be the responsibility of the Contractor, as defined herein and reported via 01 33 00 Submittal Procedures.

PART 3 - EXECUTION

3.01 GENERAL

- A. Prior to beginning work in need of dewatering, submit plans in accordance with 01 33 00 Submittal Procedures.
- B. Provide system monitoring and maintenance at least twice per day. Cease work and immediately perform any maintenance or repairs should deficiencies be found.
- C. Perform dewatering according to approved plans, providing sufficient power and backup equipment to avoid construction delays.
- D. Adapt or adjust the dewatering system to improve either performance or efficiency as necessary. All deviations from the original plan must be approved by the Hydraulic Engineer.
- E. Remove dewatering system when no longer necessary and restore any disturbed lands to pre-construction conditions or better.

END OF SECTION

SECTION 31 32 00 – SOIL STABILIZATION

PART 1 - GENERAL

1.01 SUMMARY

- A. This section addresses soil stabilization of disturbed and graded areas to establish immediate protection until vegetation establishment. Soil stabilization will include fully-biodegradable coir fabrics and fasteners to secure slopes and newly placed soils. In general, these are placed upon final soil grading, after applying seed, though typically prior to the installation of plants. Locations and specifications are detailed in the design sheets.
- B. This specification was prepared by the Hydraulic Engineer (Streamworks, PLLC) for floodplain restoration work, which is covered by the Restoration Contract being led by Streamworks PLLC and is separate from the Remedial Contract with Sanborn Head.

1.02 RELATED SECTIONS

- A. Section 01 11 00 – Summary of Work.
- B. Section 01 33 00 – Submittal Procedures.
- C. Section 01 70 00 – Execution and Closeout Requirements.

1.03 REFERENCES

- A. Not used.

1.04 DEFINITIONS

- A. Refer to Section 01 42 00 – References.

1.05 SUBMITTALS

- A. Submittals shall include:
 - 1. Comply with the requirements and procedures of Section 01 33 00 – Submittal Procedures.
 - 2. Refer to Section 01 33 00 – Submittal Procedures for a listing of submittals required under this Section.

1.06 QUALITY ASSURANCE

- A. Products must be installed according to manufacturer's specifications.
- B. Any dislodged or cut sections (i.e. cut to install plantings) must be replaced or otherwise secured to the ground.
- C. Stabilization measures must remain in good working condition until vegetation is fully established.

PART 2 - PRODUCTS

2.01 MATERIALS

- A. Heavy weight coir net:
 - 1. Shall consist of woven coir net with approximately 0.5-inch openings, with weights of 800-1,000 grams per square meter.

SECTION 31 32 00 – SOIL STABILIZATION

2. Roll widths shall be at least 4 feet wide, though 6 to 8 feet is preferred – fewer seams are desirable.
- B. Medium weight coir net:
1. Shall consist of woven coir net with approximately 1-inch openings, with weights of 600-800 grams per square meter.
 2. Roll widths shall be at least 4 feet wide, though 6 to 8 feet is preferred – fewer seams are desirable.
- C. Biodegradable fasteners:
1. May consist of any biodegradable material such as untreated wooden stakes or polypropylene/polyhydroxyalkanoate stakes
 2. Depending on the material, shall be at least 6 inches long though wooden stakes may require 12 inch lengths.
 3. Fasteners must be placed at all ends before fabrics are buried and along all seams where fabrics overlap.
 4. Place at rates specified by manufacturers according to the fabric weights; more frequent rates are encouraged.

PART 3 - EXECUTION

3.01 GENERAL

- A. Follow manufacturer guidelines for each product's installation. Install stabilization measures after finished grading and surface preparation has been performed, either in sections as sections are completed or upon final grading of the entire site. In general, work downstream to upstream so the top layer of seam is upstream. Maintain stabilization measures throughout the project duration; adjust or augment measures in the field as needed. The Contractor is responsible for the proper performance of soil stabilization measures and shall take prompt action to correct any deficiencies. Sequencing of work must consider planting and possibly seeding after stabilization measures have been installed.

3.02 PLACEMENT

- A. Coir fabrics shall be overlapped at seams and fastened together.
- B. Coir fabrics shall overlap such that upstream seams are placed on top of downstream seams. This includes both in the direction of flow and in the direction of the land slope.
- C. Coir fabrics shall be buried in shallow trenches or otherwise embedded at all ends.
- D. Fabrics shall be placed flush with the ground surface, unimpeded (raised or snagged) by underlying materials (rocks, roots, branches).

END OF SECTION

Division 31

Earth Work

SECTION 31 11 00 – CLEARING AND GRUBBING

PART 1 - GENERAL

1.01 SUMMARY

- A. Section includes requirements for grubbing, removing, and disposing of all vegetation and debris including stumps, branches, and shrubs, within the limits of work shown on the Drawings or specified below.
- B. Portions of this specification shown in *italics* were prepared by the Hydraulic Engineer (Streamworks, PLLC) for floodplain restoration work. That work is covered by the Restoration Contract being led by Streamworks PLLC and is separate from the Remedial Contract with Sanborn Head.

1.02 RELATED SECTIONS

- A. Section 01 11 00 – Summary of Work.
- B. Section 01 57 13 – Temporary Erosion and Sediment Control.

1.03 REFERENCES

- A. Refer to Section 01 41 00 – Regulatory Requirements.

1.04 DEFINITIONS

- A. Refer to Section 01 42 00 – References.

1.05 SUBMITTALS

- A. Comply with the requirements and procedures of Section 01 33 00 – Submittal Procedures.
- B. Contractor shall submit its proposed off-site permitted disposal facility(ies) for any stumps, large roots, branches, other wood, brush, weeds, grass and other perishable material and invasive species (e.g., Japanese Knotweed) resulting from the clearing and grubbing operations as part of its bid package.

1.06 QUALITY ASSURANCE

- A. The Contractor shall take care in performing clearing and grubbing operations to remove only those materials designated for removal. Any material removed by the Contractor that is not designated for removal shall be replaced solely at the Contractor's expense.
- B. Contractor shall take care when performing clearing and grubbing to avoid any damage to existing infrastructure, especially at existing retaining walls. Damage incurred to existing site features during clearing and grubbing will be restored at the expense of the Contractor.
- C. Contractor shall be responsible for the full and complete removal of all invasive species within the work limits as defined for the project.

PART 2 - PRODUCTS

2.01 MATERIALS

- A. Not Used

SECTION 31 11 00 – CLEARING AND GRUBBING

PART 3 - EXECUTION

3.01 CONSTRUCTION REQUIREMENTS

- A. Every reasonable effort shall be made to minimize the area required for performing the proposed work. Following construction layout of the project by the Contractor, the Engineer shall designate trees, stumps, shrubs, and plants to be removed as well as those to remain in place.
- B. Burning of brush will not be permitted.
- C. Contractor shall install erosion and sediment controls in areas topographically below areas which will be disturbed and shall perform the Work in a manner that limits erosion and sedimentation. Contractor shall cease work and install additional erosion and sediment control measures if ordered by Engineer or Owner.
- D. Contractor shall take care to minimize soil disturbance and dust creation during clearing and grubbing activities. Contractor shall cease work and implement dust control measures if ordered by Engineer or Owner.
- E. Contractor shall perform the work of grubbing to include the removal of brush, stumps, and large roots to a depth of not less than two feet below the cut surface unless otherwise directed by Engineer. Contractor shall take care to shake loose topsoil from root systems to remain in original location and remove as much soil as possible prior to off-site disposal.
- F. Stumps, large roots, branches, other wood, brush, weeds, grass, perishable material, and invasive species (e.g., Japanese Knotweed) resulting from the clearing and grubbing operations shall be disposed of at an off-site permitted disposal facility approved by the Engineer.
- G. *Hydraulic Engineer will flag, or instruct in the field, trees to remain as well as any trees/plants to be stockpiled and replanted for Restoration work.*
- H. *Native, non-invasive species may be chipped and reused onsite for slope stabilization and erosion control, per Section 01 57 13.*
- I. *Clearing trees and shrubs growing in and immediately adjacent to retaining walls shall be removed by hand, cut as low to the ground as possible leaving the root ball intact so damage to walls is avoided. Do not rip plants out in these locations.*
- J. *Contractor shall be responsible for the correct identification and complete removal of all invasive species within the project work limits. Invasives growing after final completion, determined to be from preconstruction sources shall be removed completely and disposed of at the expense of the Contractor.*

END OF SECTION

SECTION 31 20 00 – EARTH MOVING

PART 1 - GENERAL

1.01 SUMMARY

- A. Contractor shall furnish all labor, materials, equipment, and incidentals necessary to perform the earthwork required to complete the Work shown on the Drawings and specified herein, including, but not limited to, excavating, segregating, soil placement, compaction, and grading.
- B. Contractor shall work with the Engineer and Hydraulic Engineer and provide assistance as needed so that the required quality assurance sampling and testing may be performed. Quality assurance activities shall be considered germane to the work and not be a cause for scheduling delays. Characterization and disposal analysis will be completed by Engineer as discussed in Section 02 61 13 – Excavation and Handling of Contaminated Materials.
- C. Contractor is responsible for the satisfactory completion of the Work. If a subsequent test shows defects in materials or workmanship, Contractor, at their own expense, shall make the necessary repairs and replacements to the satisfaction of Engineer, Hydraulic Engineer, and Owner.
- D. Portions of this specification shown in *italics* were prepared by the Hydraulic Engineer (Streamworks, PLLC) for floodplain restoration work. That work is covered by the Restoration Contract being led by Streamworks PLLC and is separate from the Remedial Contract with Sanborn Head.

1.02 RELATED SECTIONS

- A. Section 01 11 00 – Summary of Work.
- B. Section 01 57 13 – Temporary Erosion and Sedimentation Control.
- C. Section 02 61 13 – Excavation and Handling of Contaminated Materials.
- D. Section 31 32 00 – Soil Stabilization
- E. Section 32 91 19.13 – Topsoil Placement and Grading.
- F. Section 32 92 19.16 – Hydraulic Seeding.
- G. Drawings.

1.03 REFERENCES

- A. Refer to Section 01 41 00 – Regulatory Requirements.

1.04 DEFINITIONS

- A. Refer to Section 01 42 00 – References.

1.05 SUBMITTALS

- A. Comply with the requirements and procedures of Section 01 33 00 – Submittal Procedures.

1.06 QUALITY ASSURANCE

- A. Not used.

SECTION 31 20 00 – EARTH MOVING

1.07 SOIL TESTING AND CONSTRUCTION MONITORING

- A. During excavation and prior to placement of backfill, the Engineer will collect soil samples from select excavation sidewalls and base for laboratory analysis. The Engineer shall also field screen soil on the base and sidewalls for lead during excavation at select excavation areas. The Contractor shall cooperate fully with the Engineer in collecting the soil samples, including providing the services of the excavator and other equipment to obtain the soil samples. The Owner will pay for the sample analysis.
- B. The Contractor will cooperate fully with the Engineer, as the Engineer will have the authority to guide Contractor to the limits of excavation as part of Remediation Work.
- C. The Contractor will cooperate fully with the Hydraulic Engineer, as the Hydraulic Engineer will have the authority to guide the Contractor to the limits of excavation as part of the Restoration Work per adaptive management permission granted by the Wetland permit.
- D. During fill placement, Engineer may select areas for testing the degree of compaction obtained. Contractor shall cooperate fully in obtaining the information desired and shall allow Engineer sufficient time to make necessary observations and tests.
- E. Payment for compaction testing will be made by Owner. If test results are unsatisfactory, all costs involved in correcting deficiencies in compacted materials to the satisfaction of Engineer and Owner will be borne by Contractor.
- F. Soil layer thickness measurements shall be made normal to the slope, not vertical.
- G. Earth Moving encompassed by Remediation efforts generally include excavation and off-Site disposal of contaminated soils to the stated subgrade depth in the Excavated Areas; backfilling and capping at the former dye house (northern terminus of Restoration area) and former Warehouse Building #2; backfilling of the remaining Excavation Areas; and staging/stockpiling of materials.
- H. *Excavation and Earth Moving encompassed by Restoration efforts generally include: removal of concrete and bedrock to subgrade elevation where found within the Restoration limits; furnishing equipment, labor, and materials appropriate for concrete and bedrock removal (no blasting allowed); backfilling with clean, imported material to achieve final grade; regrading the berm and constructing access road to Restoration area following Remediation efforts, as necessary, work on the Riverside and Upland retaining walls; and staging/stockpiling of materials.*

PART 2 - PRODUCTS

2.01 GENERAL

- A. All backfill and fill materials, unless otherwise specified, shall consist of clean, well-graded granular soil from within Excavation Area 1 – Former Mill Building Foundation Area. If material from Excavation Area 1 is not deemed suitable by the Engineer for reuse on-Site, the Contractor shall provide an off-site fill material that meets the criteria for Granular Fill in Section 2.03.
- B. The maximum particle size shall be no larger than two-thirds the lift thickness.
- C. All required fill materials shall be substantially free from organic materials, wood, trash, and other objectionable materials which may be compressible or which cannot be properly compacted. Granular Fill materials shall not contain stone blocks, asphaltic pavement, broken concrete, masonry rubble, or other similar materials. It shall have physical properties such that it can be readily spread and compacted to the specified permeability and/or density. Snow, ice, and frozen soil shall not be permitted. Do not work with or place wet, saturated material.

SECTION 31 20 00 – EARTH MOVING

2.02 ON-SITE MATERIALS

- A. The granular fill cover material to be reused from Excavation Area 1, as shown on the Drawings, shall be used as backfill and capping material for proposed capped areas outside of the Restoration Area, unless found to be unsuitable by the Engineer or unless otherwise specified.
- B. *No clean fill from onsite shall be used as backfill for Restoration work. Select other materials such as large rock rubble may be reused or buried onsite if appropriate, as designated by the Hydraulic Engineer. All unsuitable material excavated as part of Restoration efforts must be disposed of properly.*
- C. *Rock rubble (no concrete) material may be buried onsite where possible.*

2.03 GRANULAR FILL

- A. Granular Fill, unless otherwise noted, shall be obtained on-site from the cover material placed on top of geotextile fabric by the USEPA Removals Program in Excavation Area 1 – Former Mill Building Foundation Area.
- B. Granular Fill materials shall not contain stone blocks, asphaltic pavement, broken concrete, masonry rubble, and other deleterious or organic matter.
- C. If on-site material is deemed unsuitable for reuse on-Site, the Contractor shall provide alternative Granular Fill which shall have a particle-size distribution in accordance with ASTM D6913 within the following limits:

Sieve Size	Percent Finer by Weight
4-inch	100
No. 10	25 – 95
No. 40	15 – 75
No. 200	0 – 10

2.04 CRUSHED GRAVEL

- A. Crushed Gravel will be used to construct the decontamination pad and access road as well as the stabilized construction entrance.
- B. Crushed Gravel shall be free from ice, snow, roots, sod, rubbish, and other deleterious or organic matter.
- C. Crushed Gravel shall meet the particle-size distribution (ASTM D6913) requirements of NHDOT 304.3 Crushed Gravel as specified in Section 304 of the New Hampshire Department of Transportation, Standard Specifications for Road and Bridge Construction, as listed below:

Sieve Size	Percent Finer by Weight
3-inch	100
2-inch	95 - 100
1-inch	55 - 85
No. 4	27 - 52
No. 200	0 - 12*

*Based on the fraction passing the No. 4 sieve

- D. *Crushed gravel for stabilized construction entrance shall consist of 4" stone underlain by a geogrid or non-woven geotextile.*

SECTION 31 20 00 – EARTH MOVING

- E. *Graded filter material shall be used where necessary to fill voids in subgrade material to prevent topsoil from eroding and collapsing into the voids.*
- F. *Graded filter material shall consist of 3 to 9 inch angular rock sprinkled atop void areas, then by 0.5 to 2 inch angular rock sprinkled on top.*

2.05 TOPSOIL

- A. Topsoil shall be placed to a minimum thickness of 6 inches in the soil cap area(s), as directed by the Engineer.
- B. *Topsoil shall be placed to a minimum thickness of 18 inches in the Floodplain Restoration areas, as shown on the plans or as directed by the Hydraulic Engineer.*
- C. Refer to Section 32 91 19.13 – Topsoil Placement and Grading for Product specifications.
- D. Contractor shall obtain topsoil from a vendor and location approved by the Engineer and Owner.

2.06 GEOTEXTILE MARKER FABRIC

- A. Geotextile shall be installed above the subgrade (i.e., contaminated material) and below the clean soil cap as shown on the Drawings. The separator geotextile shall be a non-woven polypropylene fabric meeting the following minimum values:

PROPERTY	MINIMUM REQUIREMENT	
	ELONGATION < 50%	ELONGATION ≥ 50%
Mass/Unit Area (oz/yd ²)	6	6
Grab Strength (lbs)	270	180
Puncture Strength (lbs)	100	75
Trapezoidal Tear (lbs)	100	75
Apparent Opening Size	70 - 100 sieve	70 - 100 sieve

PART 3 - EXECUTION

3.01 PROTECTION OF EXISTING FACILITIES AND UNDERGROUND UTILITIES

- A. Contractor shall at all times during construction protect landscaping structures, retaining walls, paving, and other features outside of the limits of the Work. Contractor shall install barriers or grade the area surrounding the excavation to prevent the flow of surface water into the excavations. Contractor shall provide fences, barricades or any other means necessary to protect the public from entering the work area or open excavations.
- B. Underground utilities may exist in the work areas. Contractor shall review the locations of underground utilities with the Engineer and Owner before beginning excavation or other intrusive activities. Contractor shall review any available drawings indicating utility locations. Contractor shall contact DigSafe and obtain a Digsafe number prior to beginning any intrusive work at the site.
- C. Contractor is responsible for any damage to utilities marked by DigSafe, shown on Drawings, marked by Contractor's private utility locator, or otherwise believed to be present based on Contractor's field observations or discussions with Owner and/or Engineer. Any such utilities damaged by performance of the work shall be repaired by Contractor at no additional cost. Contractor shall repair all damaged utilities to the satisfaction of Owner and Engineer.

SECTION 31 20 00 – EARTH MOVING

- D. Contractor shall at all times during construction provide and maintain proper equipment and facilities to remove all water entering the construction area as part of this Work. This may include providing barriers to prevent surface water from flowing into excavations, and providing temporary berms, swales, and other structures as needed to redirect storm water. See Section 01 57 13 – Temporary Erosion and Sediment Control.
- E. Contractor shall plan and perform its operations to prevent damage to existing structures, safeguard people and property, minimize disruptions to site traffic, protect the structures to be installed, and provide safe working conditions in compliance with local safety regulations and provisions of the Occupational Safety and Health Act (OSHA).
- F. Contractor shall establish a temporary construction fence with a locking gate or use the existing fence and locking gate to protect the public from entering the work area. See Section 01 50 00 – Temporary Facilities and Control.
- G. Contractor shall take all necessary precautions to preclude the accidental discharge of fuel, oil, etc. in order to prevent adverse effects on surface water and groundwater quality. In the event of an accidental spill, the Owner and Engineer shall be notified immediately. All free liquids shall be cleaned up and all contaminated soil shall be excavated and disposed of properly by the Contractor at the Contractor's expense. Contractor shall install barriers or grade the area surrounding the excavation to prevent the flow of surface water into excavations. Contractor shall provide fences, barricades or any other means necessary to protect the public from entering the work area or open excavations.
- H. *Contractor shall not excavate down to the toe of the existing Upland retaining wall, which is assumed to be somewhere near elevation 572-574 feet NAVD88. Remove only enough material so backfill may be placed atop a toe protection slope as shown in the Drawings.*

3.02 GENERAL EXCAVATION BELOW GRADE

- A. Excavations shall be made to the elevations and dimensions shown on the Drawings. Excavate sufficient material to provide suitable room for construction providing bracing and support as required. The bottom of the excavations shall be rendered firm and dry and in all respects acceptable to the Engineer.
- B. Remove, by pumping or other means, water accumulated in excavations to maintain a dry and stable subgrade until earthwork operations are complete. All dewatering shall be performed at the Contractor's cost. Coordinate with Section 31 23 19 – Dewatering.
- C. Where the soil subgrade is softened, eroded, or otherwise disturbed by flooding, exposure during unfavorable weather, or other causes, it shall be over-excavated and replaced with suitable material at no cost to the Owner.
- D. When the required excavation depth and horizontal extent is achieved, the Contractor shall notify the Engineer that the excavation is ready for inspection and sampling. If, in the opinion of the Engineer, the material still contains lead in concentrations above the cleanup level, then the Contractor shall increase the size of the excavation as directed by the Engineer.
- E. The Contractor shall exercise care to preserve the material below and beyond the lines of excavation. If the bottom of an excavation is extended below the limits shown on the Drawings or specified or directed by the Engineer, it shall be filled and compacted in accordance with these specifications.
- F. Where deeper than three feet, the Contractor shall slope the excavation as indicated in the Drawings. All soil from the sloped cut shall stockpiled separately and used to backfill the excavation.
- G. *Excavation below grade for Remediation efforts shall be limited to contaminated material. Excavation below grade for Restoration efforts shall remove all remaining materials – in particular large rock rubble, concrete, and bedrock – down to subgrade elevation.*

SECTION 31 20 00 – EARTH MOVING

- H. *Excavation of solid materials (concrete including former Boiler House foundation slab and bedrock) shall require appropriate equipment – an excavator with a hammer attachment, for example – and blasting is not allowed. Concrete is evident and protruding from the existing surface. Bedrock is prevalent at the site and surrounding lands; borings have indicated its presence within the excavation limits, though Contractor shall be prepared for bedrock extents to be variable.*
- I. *Excavation of Restoration (non-contaminated) materials shall be disposed of properly at pre-approved facilities and is not anticipated to need to be treated as contaminated waste. If contamination is identified during construction, Contractor will work with the Engineer to coordinate proper off-site disposal.*
- J. *Where discovered, remove unnatural material such as metal debris or disconnected drain pipes so long as the material is easily removable. This applies primarily to the southern section of the Restoration area (at the former water wheel) where debris is visible. Dispose of this material appropriately at pre-approved facilities.*
- K. *All excavation shall be done 'in the dry,' dewatered as necessary. Dewatering is expected to be limited, though likely necessary at the southern end of the Restoration area near the former water wheel. Coordinate with Section 31 23 19 – Dewatering.*

3.03 SUBGRADE PREPARATION – GENERAL

- A. Prior to fill placement, the subgrade should be compact, dry, and free from debris, ice, and snow. Fill shall not be placed over frozen soil unless otherwise approved by Engineer.
- B. Contractor shall place geotextile membrane fabric on subgrade (i.e., contaminated material) prior to clean fill placement. Placement of the membrane shall be done in such a manner as to minimize disturbance of the underlying ground. Deterioration of the subgrade prior to initial fill placement shall be the responsibility of Contractor and shall be repaired at Contractor's expense.
- C. All subgrades will be observed by Engineer prior to fill placement. Sufficient time must be given to Engineer to inspect and perform any necessary tests on the subgrade.
- D. *When excavation to subgrade elevation has been completed, some lands may consist of material with large voids – particularly where large rock rubble is found. When subgrade surfaces contain voids, a graded filter shall be used to prevent topsoil from eroding and collapsing into the voids.*
- E. *Graded filter shall consist first of larger, cobble-sized rock followed by smaller, gravel-sized rock with the goal being a gradual filling of all voids.*
- F. *When graded filter has been placed, lay a thin layer (approximately 2 inches) of topsoil on top and gently – ensuring no material erodes onto adjacent lands or into the river – wash the material into the filter. Repeat this as necessary until topsoil no longer washes into the filter.*
- G. *Graded filter shall be placed no higher than 4 inches above the final subgrade elevation.*

3.04 BACKFILLING – GENERAL

- A. All fill shall be placed “in the dry.” The fill areas shall be graded to drain and provide a smooth surface, which will readily shed water.
- B. Fill containing ice, snow, frozen soil, large rocks, or other deleterious material shall not be placed.
- C. Fill placement shall not be allowed during weather conditions that do not allow for proper moisture and density controls.
- D. Fill that is too wet for proper compaction shall be disced, harrowed, rototilled, or otherwise dried to a proper moisture content for compaction to the required density.

SECTION 31 20 00 – EARTH MOVING

- E. Fill that is too dry for proper compaction shall receive water uniformly applied over the surface of the loose layer. Compaction shall not be performed until the moisture content of the fill material is uniform. Sufficient water shall be added to allow for compaction to the required density at the required moisture content.
- F. The Engineer will observe construction and perform moisture content, particle size, and compaction tests at a frequency and at locations selected by the Engineer. Where tests indicate that fill does not conform to the specified compaction, the Contractor shall remove and recompact the fill to the specified density without additional cost to the Owner.
- G. The Engineer's presence does not include supervision or direction of the actual work by the Contractor, his employees, or agents. Neither the presence of the Engineer nor any observations and testing performed by him shall excuse the Contractor from defects discovered in their work.
- H. *Non-contaminated material (primarily rock rubble) may be buried onsite (at the Upland retaining wall toe slope or at the southern Restoration terminus, for example). When burying material which creates voids, a graded filter must be placed atop first so soil backfill does not erode and collapse (see 3.03 above).*

3.05 FILL PLACEMENT – RELOCATION OF ON-SITE SOIL

- A. The Contractor shall place on-site soil from Excavation Areas 3 and 4 – Areas Northeast of the Former Dye House and Excavation Area 5 – Embankment in loose lifts, not to exceed twelve (12) inches in the Former Warehouse Building #2 Cap Area. The maximum thickness may be less depending on the Contractor's equipment and amount of material available from the excavations. The maximum in-place compacted thickness for the placed soils shall not be more than twelve (12) inches.
- B. The soils shall be compacted with at least four (4) passes of a 10,000-pound vibratory, smooth-drum roller.

3.06 FILL PLACEMENT – SOIL CAP AND EXCAVATION AREAS

- A. The Contractor shall place the Granular Fill in loose lifts not exceeding nine (9) inches. The maximum thickness may be less depending on the Contractor's equipment and depth of the excavation. The minimum in-place compacted thickness for the soil caps shall be not less than twelve (12) inches for the Granular Fill.
- B. Upon approval by the Engineer, the cap for the Former Dye House Cap Area may be constructed using rubble/boulders from Excavation Area 1 – Former Mill Building Foundation Area. If rubble/boulders are used as capping material, the excavator bucket shall be used to compact the cap material.
- C. The Contractor shall use equipment appropriate for spreading the fill in a uniform layer across the lift.
- D. The Contractor shall compact the Granular Fill with at least four (4) passes of a 10,000-pound vibratory, smooth-drum roller. If 10,000-pound vibratory, smooth-drum roller cannot be practically used due to the small size and depth of an excavation, a vibratory plate compactor may be used.

3.07 FILL COMPACTION CRITERIA

- A. The Contractor shall compact each lift of fill sufficiently to destroy all clods and knead the soil mass together, producing a uniform, homogeneous mass free of all defects, cracks and fissures.
- B. Granular Fill placed shall be compacted to a density no less than 90% of the maximum dry density and at a moisture content within 2% of the optimum moisture content as determined by ASTM D698.

SECTION 31 20 00 – EARTH MOVING

3.08 FILL PLACEMENT – RESTORATION LIMITS

This describes fill placement within the Restoration limits except where fill has been placed and set to final grade as part of Remediation efforts (primarily the northern terminus of the Restoration work).

- A. *Contractor shall first ensure all concrete and bedrock has been removed down to desired subgrade.*
- B. *Place any existing material to be buried into appropriate locations, when necessary.*
- C. *Backfill the Restoration area to final grade with clean, imported topsoil.*
- D. *Topsoil shall be free from invasive species, without clumps and rock/debris larger than 3 inches, and be clean, imported fill.*
- E. *Do not over-compact topsoil, compact in 4-6 inch lifts using the excavator bucket or tracks.*
- F. *Set topsoil elevation between 0 to 2 inches above final grade to allow for settling.*
- G. *At the toe of the Upland retaining wall, ensure base of wall is never exposed. Construct a toe slope protection at 1:1 to 1:1.5 slope as indicated in the Drawings.*

3.09 EARTH MOVING – RETAINING WALLS

- A. *Refer to the Restoration Drawings for further instructions.*
- B. *Remove and rebuild the Riverside retaining wall to an elevation of 574.0' NAVD88. Perform this work cautiously to avoid damage to the wall. An excavator with a thumb is recommended.*
- C. *During Riverside wall work, construct a temporary path made from 4 inch crushed stone, similar to the construction of the Construction Access, underlain with a heavy weight non-woven geotextile (9 oz/sy or greater) or a geogrid.*
- D. *Remove/restore/rebuild the Upland retaining wall by chinking voids with materials recycled from onsite. Mortar material and voids together.*
- E. *Stockpile materials to be reused and/or disposed of for use in retaining wall construction or as fill.*

END OF SECTION

SECTION 31 23 19 – DEWATERING

PART 1 - GENERAL

1.01 SUMMARY

- A. Dewatering is required wherever excavation or work must be performed where water has pooled. At the site this is anticipated primarily at the south end of the project where water from the river enters during higher stages and cannot get back out, though will be required elsewhere if groundwater or runoff enters excavated lands. Dewatering applies to water which has not been in contact with contaminated soils, and will be permitted under the Wetland permit. Work, in general, shall include:
1. Furnish all labor, materials, tools, and equipment, and perform all operations necessary for dewatering as indicated on the Drawings and as specified herein.
 2. Design of the entire temporary dewatering system and make whatever modifications and/or additions to the system as may be required for the system to fulfill its requirements.
 3. Provide filter materials and/or other structures needed to treat pumped water. Pumped water must be filtered until clear before being released.
 4. Provide system monitoring and maintenance by someone skilled in the operation, maintenance, and replacement of system components as well as any other equipment and work required by the Hydraulic Engineer to maintain the excavation dry. Some responsible person shall continuously monitor the dewatering and surface water central systems, until the Contractor has received approval from the Hydraulic Engineer that dewatering may be discontinued
- B. This specification was prepared by the Hydraulic Engineer (Streamworks, PLLC) for floodplain restoration work, which is covered by the Restoration Contract being led by Streamworks PLLC and is separate from the Remedial Contract with Sanborn Head.

1.02 RELATED SECTIONS

- A. Section 01 11 00 – Summary of Work.
- B. Section 01 33 00 – Submittal Procedures.
- C. Section 01 57 13 – Temporary Erosion and Sedimentation Controls.
- D. Section 01 70 00 – Execution and Closeout Requirements.

1.03 REFERENCES

- A. Not used.

1.04 DEFINITIONS

- A. Refer to Section 01 42 00 – References.

1.05 SUBMITTALS

- A. Submittals shall include:
1. Comply with the requirements and procedures of Section 01 33 00 – Submittal Procedures.
 2. Refer to Section 01 33 00 – Submittal Procedures for a listing of submittals required under this Section.

SECTION 31 23 19 – DEWATERING

1.06 QUALITY ASSURANCE

- A. Products must be used according to manufacturer’s specifications.
- B. No untreated water may enter the river.
- C. Filtered water must not be returned to lands containing contaminated soils.
- D. Water must be treated until clean.
- E. Treated water must not cause erosion to any land nor be allowed to pond elsewhere onsite.
- F. Trapped material shall be disposed of appropriately.
- G. Dewatering must be designed and implemented to avoid impacts to the site and surrounding lands to the maximum extent practicable.
- H. Maintenance and inspection of equipment must occur at the beginning and end of each day. Any issue must be fixed immediately before resuming work.

PART 2 - PRODUCTS

2.01 MATERIALS

- A. Products and equipment shall be the responsibility of the Contractor, as defined herein and reported via 01 33 00 Submittal Procedures.

PART 3 - EXECUTION

3.01 GENERAL

- A. Prior to beginning work in need of dewatering, submit plans in accordance with 01 33 00 Submittal Procedures.
- B. Provide system monitoring and maintenance at least twice per day. Cease work and immediately perform any maintenance or repairs should deficiencies be found.
- C. Perform dewatering according to approved plans, providing sufficient power and backup equipment to avoid construction delays.
- D. Adapt or adjust the dewatering system to improve either performance or efficiency as necessary. All deviations from the original plan must be approved by the Hydraulic Engineer.
- E. Remove dewatering system when no longer necessary and restore any disturbed lands to pre-construction conditions or better.

END OF SECTION

SECTION 31 32 00 – SOIL STABILIZATION

PART 1 - GENERAL

1.01 SUMMARY

- A. This section addresses soil stabilization of disturbed and graded areas to establish immediate protection until vegetation establishment. Soil stabilization will include fully-biodegradable coir fabrics and fasteners to secure slopes and newly placed soils. In general, these are placed upon final soil grading, after applying seed, though typically prior to the installation of plants. Locations and specifications are detailed in the design sheets.
- B. This specification was prepared by the Hydraulic Engineer (Streamworks, PLLC) for floodplain restoration work, which is covered by the Restoration Contract being led by Streamworks PLLC and is separate from the Remedial Contract with Sanborn Head.

1.02 RELATED SECTIONS

- A. Section 01 11 00 – Summary of Work.
- B. Section 01 33 00 – Submittal Procedures.
- C. Section 01 70 00 – Execution and Closeout Requirements.

1.03 REFERENCES

- A. Not used.

1.04 DEFINITIONS

- A. Refer to Section 01 42 00 – References.

1.05 SUBMITTALS

- A. Submittals shall include:
 - 1. Comply with the requirements and procedures of Section 01 33 00 – Submittal Procedures.
 - 2. Refer to Section 01 33 00 – Submittal Procedures for a listing of submittals required under this Section.

1.06 QUALITY ASSURANCE

- A. Products must be installed according to manufacturer's specifications.
- B. Any dislodged or cut sections (i.e. cut to install plantings) must be replaced or otherwise secured to the ground.
- C. Stabilization measures must remain in good working condition until vegetation is fully established.

PART 2 - PRODUCTS

2.01 MATERIALS

- A. Heavy weight coir net:
 - 1. Shall consist of woven coir net with approximately 0.5-inch openings, with weights of 800-1,000 grams per square meter.

SECTION 31 32 00 – SOIL STABILIZATION

2. Roll widths shall be at least 4 feet wide, though 6 to 8 feet is preferred – fewer seams are desirable.
- B. Medium weight coir net:
1. Shall consist of woven coir net with approximately 1-inch openings, with weights of 600-800 grams per square meter.
 2. Roll widths shall be at least 4 feet wide, though 6 to 8 feet is preferred – fewer seams are desirable.
- C. Biodegradable fasteners:
1. May consist of any biodegradable material such as untreated wooden stakes or polypropylene/polyhydroxyalkanoate stakes
 2. Depending on the material, shall be at least 6 inches long though wooden stakes may require 12 inch lengths.
 3. Fasteners must be placed at all ends before fabrics are buried and along all seams where fabrics overlap.
 4. Place at rates specified by manufacturers according to the fabric weights; more frequent rates are encouraged.

PART 3 - EXECUTION

3.01 GENERAL

- A. Follow manufacturer guidelines for each product's installation. Install stabilization measures after finished grading and surface preparation has been performed, either in sections as sections are completed or upon final grading of the entire site. In general, work downstream to upstream so the top layer of seam is upstream. Maintain stabilization measures throughout the project duration; adjust or augment measures in the field as needed. The Contractor is responsible for the proper performance of soil stabilization measures and shall take prompt action to correct any deficiencies. Sequencing of work must consider planting and possibly seeding after stabilization measures have been installed.

3.02 PLACEMENT

- A. Coir fabrics shall be overlapped at seams and fastened together.
- B. Coir fabrics shall overlap such that upstream seams are placed on top of downstream seams. This includes both in the direction of flow and in the direction of the land slope.
- C. Coir fabrics shall be buried in shallow trenches or otherwise embedded at all ends.
- D. Fabrics shall be placed flush with the ground surface, unimpeded (raised or snagged) by underlying materials (rocks, roots, branches).

END OF SECTION

Division 32

Exterior Improvements

SECTION 32 32 00 – RETAINING WALLS

PART 1 - GENERAL

1.01 SUMMARY

- A. Section describes all work relating to retaining walls – furnishing materials, labor, equipment and supervision – in accordance with the Drawings and specifications herein.
- B. Two retaining walls exist at the site: one adjacent to the river to the west (herein referred to as the Riverside retaining wall), and one to the east adjacent to the former railroad (herein referred to as the Upland retaining wall). Both walls were part of the foundation to the former mill building.
- C. Both retaining walls are to be built/rebuilt/reinforced as specified in the Drawings.
- D. This specification was prepared by the Hydraulic Engineer (Streamworks, PLLC) for floodplain restoration work, which is covered by the Restoration Contract being led by Streamworks PLLC and is separate from the Remedial Contract with Sanborn Head.

1.02 RELATED SECTIONS

- A. Section 01 11 00 – Summary of Work.
- B. Section 01 33 00 – Submittal Procedures.
- C. Section 01 70 00 – Execution and Closeout Requirements.

1.03 REFERENCES

- A. Drawings.

1.04 DEFINITIONS

- A. Refer to Section 01 42 00 – References.

1.05 SUBMITTALS

- A. Submittals shall include:
 - 1. Product data for mortar (or other material used to reinforce walls).

1.06 QUALITY ASSURANCE

- A. Rocks used for rock walls must be free from cracks or other imperfections which may make them less strong and susceptible to failure.
- B. Rocks to be reused for rock walls must first be set aside for inspection by the Hydraulic Engineer prior to use.
- C. Use rocks which are more rectangular in shape.

PART 2 - PRODUCTS

2.01 MATERIALS

- A. Rock
 - 1. Rocks, large and small, will consist of materials found on site.

SECTION 32 32 00 – RETAINING WALLS

2. Larger rocks for primary structure may be any size, though should generally have a middle dimension of 1 foot or greater, weighing 400 pounds or more.
3. Smaller rocks may be of any size, selected as necessary to fill gaps in the larger rocks.
4. ¾-inch crushed stone to backfill behind placed rocks.

B. Mortar

1. Mortar may be proposed by the Contractor, subject to Hydraulic Engineer approval.
2. Common mortar types for granite rock retaining walls include Type N and Hydraulic Lime (NHL) mortar.

PART 3 - EXECUTION

3.01 GENERAL

- A. Perform Work as detailed in the Drawings and herein.
- B. Do not damage existing retaining walls, use extreme caution when working on and around walls.
- C. Do not excavate behind retaining walls more than necessary as in the Drawings or as instructed in the field by the Hydraulic Engineer.
- D. Do not rip anything out of the wall – primarily trees and pipes – instead cut them flush with the wall where exposed.

3.02 RIVERSIDE RETAINING WALL

- A. The riverside retaining wall shall be removed as detailed in the Drawings, down to a low elevation of 574.0'.
- B. Excavate down to the subgrade elevation (572.5'). Excavate below as necessary to remove larger rocks from the wall to prevent material slumping into the river and onto the wall.
- C. Remove cap rocks and wall rocks one at a time. Wall rocks entirely above elevation 574.0' shall be removed. Small rocks partially above elevation 574.0' may be removed or left in place. Large rocks mostly above elevation 574.0' may be removed, then the gap filled with mortar and smaller rocks. Large rocks mostly below and rocks entirely below elevation 574.0' may remain in place.
- D. Stockpile materials to be reused in construction of the Upland retaining wall.
- E. The top of the finished wall should have a jagged, irregular shape, with a low elevation at 574.0'.

3.03 UPLAND RETAINING WALL

- A. Reinforcement of Existing Wall:
 1. Reinforcement of the existing wall shall be done by removing all loose chinking stone and mortar. Replace existing chinking stone and supplement with additional material to fill gaps. Mortar all chink stone and fill all gaps with mortar.
 2. Reinforcement of the wall shall be done for the entire face exposed under existing conditions as well as that which is exposed after excavation
 3. Prior to placing mortar, surfaces shall be reasonably cleaned from dirt, lichen, debris, or other materials which compromise bonding.

SECTION 32 32 00 – RETAINING WALLS

B. Reconstruction of Removed Section:

1. Construct as shown in the Drawings, as a rock step system rather than vertical wall.
2. Slope of rock steps should nearly match that of the existing earth ramp, about 1.5:1.
3. Using rocks found onsite, set a first layer of rocks atop the existing retaining wall where discovered below earth ramp.
 - a. Adaptive management may be required to redesign this work should the existing retaining wall be absent or much lower than assumed.
4. Use mortar and smaller rocks to fill gaps as necessary. Leave intermittent gaps smaller than 4 inches to allow weep.
5. Repeat stacking layers, filling gaps, and mortar until reaching existing ground.

END OF SECTION

SECTION 32 91 19.13 – TOPSOIL PLACEMENT AND GRADING

PART 1 - GENERAL

1.01 SUMMARY

- A. The Contractor shall furnish all labor, materials, equipment and incidentals required to furnish, place, grade, and maintain Topsoil.
- B. Portions of this specification shown in *italics* were prepared by the Hydraulic Engineer (Streamworks, PLLC) for floodplain restoration work. That work is covered by the Restoration Contract being led by Streamworks PLLC and is separate from the Remedial Contract with Sanborn Head.

1.02 RELATED SECTIONS

- A. Section 01 11 00 – Summary of Work.
- B. Section 31 20 00 – Earth Moving.
- C. Section 31 32 00 – Soil Stabilization
- D. Section 32 92 19.16 – Hydraulic Seeding.

1.03 REFERENCES

- A. Refer to Section 01 41 00 – Regulatory Requirements.

1.04 DEFINITIONS

- A. Refer to Section 01 42 00 – References.

1.05 SUBMITTALS

- A. Refer to Section 01 33 00 - Submittal Procedures.

1.06 QUALITY ASSURANCE

- A. Not used.

1.07 SAMPLES AND APPROVAL OF MATERIAL

- A. Samples of all materials shall be submitted for inspection and acceptance upon Engineer's request.

PART 2 - PRODUCTS

2.01 MATERIALS

- A. Topsoil shall be fertile, natural soil capable of sustaining vigorous plant growth, typical of the locality, free from stones greater than 3 inches, roots, sticks, clay, peat, weeds, and sod and obtained from naturally well drained areas. It shall not be excessively acidic or alkaline nor contain toxic material harmful to plant growth. Topsoil selected by the Contractor shall be approved by the Engineer.

PART 3 - EXECUTION

3.01 APPLICATION

- A. Unless otherwise shown on the Drawings, Topsoil shall be placed to a minimum thickness of 6 inches in Cap locations.
- B. Topsoil shall be placed on the Former Dye House Cap Area by the Contractor at the Engineer's judgement.

SECTION 32 91 19.13 – TOPSOIL PLACEMENT AND GRADING

- C. *Topsoil shall be placed to a typical thickness of 18 inches for Restoration areas, unless otherwise shown in the Drawings or as instructed by the Hydraulic Engineer.*
- D. *Restoration topsoil shall conform to specifications outlined in Section 31 20 00 – Earth Moving.*

3.02 INSTALLATION

- A. The surface to be covered with Topsoil shall be observed and approved by the Engineer before Topsoil is placed. After Topsoil has been spread and fine graded, all large stiff clods, lumps, brush, roots, stumps, litter and other foreign material shall be removed from the area covered with Topsoil and disposed of by the Contractor.
- B. On slopes, the Contractor shall protect against wash-outs by an approved method. Any wash-out that occurs shall be regraded and reseeded at the Contractor's expense until a good sod cover is established. Coordinate with Section 31 32 00 – Soil Stabilization.
- C. The observations by the Engineer or Owner will determine whether maintenance shall continue in any area or manner.
- D. *Do not over-compact topsoil at Floodplain Restoration areas; compact using an excavator bucket by pushing or tamping down material in 6-inch lifts.*

END OF SECTION

SECTION 32 92 19.16 – HYDRAULIC SEEDING

PART 1 - GENERAL

1.01 SUMMARY

- A. The Contractor shall furnish all labor, materials, equipment and incidentals required to furnish and hydraulically apply seed and mulch and maintain all seeded areas as specified herein.
- B. Contractor shall seed all areas disturbed by construction operations. All areas disturbed or not having sufficient vegetation to prevent erosion shall be seeded.

1.02 RELATED SECTIONS

- A. Section 01 11 00 – Summary of Work.
- B. Section 31 20 00 – Earth Moving.
- C. Section 32 91 19.13 – Topsoil Placement and Grading.

1.03 REFERENCES

- A. Refer to Section 01 41 00 – Regulatory Requirements.

1.04 DEFINITIONS

- A. Refer to Section 01 42 00 – References.

1.05 SUBMITTALS

- A. Refer to Section 01 33 00 - Submittal Procedures.

1.06 QUALITY ASSURANCE

- A. Not used.

1.07 SAMPLES AND APPROVAL OF MATERIAL

- A. Samples of all materials shall be submitted for inspection and acceptance upon Engineer's request.
- B. The Contractor shall submit the proposed seed mix including the manufacturer's certificate of compliance to the Engineer for review prior to seeding.
- C. When hydroseeding is to be performed, submit a certified statement of the number of pounds of lime, fertilizer and seed to be used per 100 gallons of water and specifying the number of square feet that can be covered with the volume of solution in the sprayer.

PART 2 - PRODUCTS

2.01 MATERIALS

- A. Fertilizer shall be a complete commercial fertilizer for grass areas. It shall be delivered to the site in the original unopened containers each showing the manufacturer's guaranteed analysis. Fertilizer shall be stored so that when used it shall be dry and free flowing.
- B. Lime shall be ground limestone containing not less than eighty-five percent (85%) calcium and magnesium carbonates.

SECTION 32 92 19.16 – HYDRAULIC SEEDING

- C. Grass seed shall be from the same or previous year's crop; each variety of seed shall have a percentage of germination not less than ninety (90), a percentage of purity of not less than eighty-five (85) and shall have not more than one percent (1%) weed content. The seed mixture shall conform to the requirements of Slope Seed Type 15 as specified in Section 644 of the New Hampshire Department of Transportation, Standard Specifications for Road and Bridge Construction, or other seed mix approved by the Engineer.
- D. The seed shall be furnished and delivered premixed in the proportions specified above. A manufacturer's certificate of compliance of the specified mix shall be submitted by the manufacturer for each seed type. These certificates shall include the guaranteed percentages of purity, weed content and germination of the seed, and also the net weight and date of shipment. No seed may be sown until the Contractor has submitted the certificates.
- E. Fertilizer, seed, and lime shall be furnished in new, clean, sealed, and properly labeled bags, with the following information clearly marked:
 - 1. Manufacturer name
 - 2. Type
 - 3. Weight
 - 4. Guaranteed analysis
- F. Mulch shall be hay mulch consisting of dry hay or straw mulch free of mold, primary noxious weed seeds, twigs, debris, and rough or woody materials. Do not use mulch material which is fresh or excessively brittle, or which is decomposed and will smother or retard growth of grass.
- G. Supply potable water, free of substances harmful to growth.

PART 3 - EXECUTION

3.01 APPLICATION

- A. The Contractor shall place seed/fertilizer by hand or through hydroseeding, depending on feasibility and area of disturbance.
- B. For all areas to be seeded a minimum of the following shall be applied:
 - 1. Lime shall be applied uniformly over the area at the rate defined in Table 642-1 of the NHDOT Specifications.
 - 2. Fertilizer shall be applied uniformly over the area at the rate defined in Table 643-1 of the NHDOT.
 - 3. Seed shall be applied uniformly over the area at the minimum rate defined in Table 644-3 of the NHDOT Specifications.
- C. The Contractor shall use care when mixing fertilizer to assure the mix is in accordance with this specification and to preclude over fertilizing. If using sprayers, they shall be loaded over vegetated surfaces. Empty containers shall be disposed of in accordance with instructions on the product label.
- D. In the event of a spill of fertilizer or hydroseed mix, the Engineer shall be notified and the spill shall be cleaned up promptly.
- E. The application of fertilizer and lime shall be performed hydraulically in one operation with hydroseeding.

SECTION 32 92 19.16 – HYDRAULIC SEEDING

- F. The application of hay mulch is to be by pneumatic blower.

3.02 INSTALLATION

- A. Areas to be seeded shall be raked and all rubbish, sticks, roots, and stones larger than 4 inches shall be removed.
- B. Fertilizer, lime, seed, and mulch shall not be applied to the areas not to be vegetated such as: pavement, gabions, rip rap, gravel access roads, etc.
- C. Fertilizer, lime, seed, and mulch shall only be applied during those periods within the seasons that are normal for such work as determined by the weather and locally accepted practice, and as approved by the Engineer. Seeding and fertilizing shall be performed between April 1 and June 1 or between August 15 and October 15, or as directed or permitted by the Engineer. The Contractor shall seed and mulch (if needed) only on a calm day and shall not seed when heavy precipitation is expected.
- D. Schedules for seeding and fertilizing must be submitted to the Engineer and Owner for approval prior to the work being performed.
- E. Seeding shall be done within five (5) days following soil preparation.
- F. When protection of newly graded areas is necessary at a time that is outside of the normal seeding season, the Contractor shall protect those areas by whatever means necessary (such as straw or erosion control mats) or by other measures as approved by the Engineer and Owner.

3.03 MAINTENANCE AND PROVISIONAL ACCEPTANCE

- A. The Contractor shall keep all seeded areas watered and in good condition, shall reseed if and when necessary until a good, healthy, uniform growth is established over the entire area seeded, and shall maintain these areas in an approved condition until provisional acceptance.
- B. On slopes, the Contractor shall protect against wash-outs by an approved method. Any wash-out that occurs shall be regraded and reseeded at the Contractor's expense until a good sod cover is established.
- C. The Engineer or Owner will observe work for provisional acceptance at the end of the eight (8) week grass maintenance period, and upon the written request of the Contractor, which must be received at least ten (10) days before the anticipated date of observation.
- D. A satisfactory stand will be defined as a section of grass of 10,000 square feet or larger that has:
 - 1. No bare spots larger than (3) square feet.
 - 2. No more than ten percent (10%) of total area with bare spots larger than one (1) square foot.
 - 3. No more than fifteen percent (15%) of total area with bare spots larger than 6 inches square.
- E. The observations by the Engineer or Owner will determine whether maintenance shall continue in any area or manner.
- F. After all necessary corrective work and cleanup has been completed, the Engineer or Owner will acknowledge the provisional acceptance of the seeded areas. The Contractor's responsibility for maintenance of seeded areas, or parts of seeded areas shall cease on receipt of provisional acceptance.

3.04 GUARANTEE PERIOD AND FINAL ACCEPTANCE

- A. All seeded areas shall be guaranteed by the Contractor for not less than one (1) full year from the time of provisional acceptance.

SECTION 32 92 19.16 – HYDRAULIC SEEDING

- B. At the end of the guarantee period, the Engineer or Owner will make observations upon written request submitted by the Contractor at least ten (10) days before the anticipated date. Seeded areas not demonstrating satisfactory stands as outlined above, as determined by the Engineer or Owner, shall be renovated, reseeded, and maintained meeting all requirements as specified herein.
- C. After all necessary corrective work has been completed, the Engineer or Owner shall acknowledge in writing the final acceptance of the seeded areas.

END OF SECTION

SECTION 32 93 00 – PLANTS

PART 1 - GENERAL

1.01 SUMMARY

- A. Section describes work related to planting shrubs and trees – not seeding – of the riparian floodplain restoration. For seeding, refer to Sections 31 32 00 – Soil Stabilization and 32 92 19.16 – Hydraulic Seeding. Contractor shall furnish all labor, materials, supplies, equipment to complete the installation of plantings and guarantee plantings. Work under this section shall include, but is not limited to:
 - 1. Procurement.
 - 2. Soil and ground inspection and preparation.
 - 3. Installation.
 - 4. Watering during construction (if necessary).
 - 5. Securing or protecting (if necessary).
 - 6. Mulching and final regrading.
 - 7. Cleanup, inspection, documentation, and approval.
 - 8. Guarantee of plants and installation.
- B. This specification was prepared by the Hydraulic Engineer (Streamworks, PLLC) for floodplain restoration work, which is covered by the Restoration Contract being led by Streamworks PLLC and is separate from the Remedial Contract with Sanborn Head.

1.02 RELATED SECTIONS

- A. Section 01 11 00 – Summary of Work.
- B. Section 01 33 00 – Submittal Procedures.
- C. Section 01 70 00 – Execution and Closeout Requirements.
- D. Section 32 91 19.13 – Topsoil Placement and Grading
- E. Section 31 32 00 – Soil Stabilization

1.03 REFERENCES

- A. NHDES Native Shoreland/Riparian Buffer Plantings for New Hampshire.
- B. American Nursery and Landscape Association (ANLA): ANSI Z60.1, American Standard for Nursery Stock

1.04 DEFINITIONS

- A. Refer to Section 01 42 00 – References.

1.05 SUBMITTALS

- A. Submittals shall include:
 - 1. Product Data and Facility of Origin – Trees, Shrubs, Livestakes (includes support materials like stakes, rope, deterrents).

SECTION 32 93 00 – PLANTS

2. Documentation of Successful Installation

1.06 QUALITY ASSURANCE

- A. Plants are delivered and installed alive and healthy.
- B. Plants are all free from invasives, cuts, disease, rot, or other maladies.
- C. Plants consist of native, riparian species in New Hampshire and that they will be viable growing in the soil/backfill placed at the site without needing fertilizer or continued care. Plants should be delivered to the site bearing tags with their botanic names.
- D. Plants are protected and cared for at all times to prevent drying out and injury.
 - 1. Plants shall be securely tarped during transportation to prevent wind burn, loss of foliage, and drying out.
 - 2. Plants are handled gently to avoid injury and that root balls are kept intact.
 - 3. Plants are stored appropriately if not installed immediately upon delivery: protect root balls with soil or other suitable material; store plants in the shade and off impervious surfaces; keep all plant roots moist but not saturated; secure plants as necessary to maintain them in an upright position.
- E. Plants are appropriately placed according to rooting depth, soil, and light preferences. For example, trees with deeper rooting depths should not be placed where bedrock is shallow, and trees preferring full sun should not be placed near the upland retaining wall.

1.07 GUARANTEE AND REPLACEMENT

- A. Guarantee trees and shrubs are successful for at least one growing season. Exceptions will be made if failures are due to factors outside the Contractor's control – i.e. ignorance by designated post-construction Maintenance personnel, vandalism, or an act-of-god event. Exceptions will be determined by the Hydraulic Engineer and/or an appropriate Professional.
- B. Replace plants when they are no longer in a satisfactory condition. Replacements shall occur immediately upon discovery, unless it is during the species' dormant season.
- C. All replacements shall be of the same kind and size as the originals, placed in the same location unless otherwise directed by the Hydraulic Engineer. All costs for replacement shall be made at no expense to Owner.
- D. The same guarantee for original plants shall apply to all replacement plants, including the guarantee period of one full growing season after installation.

PART 2 - PRODUCTS

2.01 GENERAL

- A. Plant species, installation areas, construction planting rates, and minimum long-term densities are defined in the Drawings.
- B. Plant species given in the Drawings are common riparian species, and is not a complete list; additional species may be installed at the discretion of a professional and approved by the Hydraulic Engineer.
- C. All purchased materials used for construction shall be new and without flaws or defects of any kind and remain in this condition upon final project closeout.

SECTION 32 93 00 – PLANTS

- D. Few trees exist at the current site, however those within work limits which are suitable and would otherwise be cleared may be transplanted.
- E. Plantings shall primarily consist of container stock, though smaller species may be substituted for livestock, at given ratios as laid out in the Drawings.
- F. All plants shall be installed per supplier's specifications and as appropriate for each species, including consideration given to seasonal

2.02 MATERIALS

A. Plants

- 1. Furnish sufficient plants in quantities required to complete the project as indicated on the Drawings
- 2. Use plants which are healthy and typical of their species; well-branched and well-proportioned between width and height; free from disease, injury, rot, and weak roots.
- 3. Plant names conform to standard horticultural nomenclature for the area. Plants shall all be native species, not hybrids.
- 4. Ground cover vegetation shall conform to 31 32 00 – Soil Stabilization and 32 92 19.16 – Hydraulic Seeding

B. Anchors and Protection

- 1. Installed plants shall be anchored according to supplier recommendations when necessary.
- 2. Anchor materials must be fully biodegradable and last until the anchored plant has sufficient roots to be stable alone. Exceptions may be made for small fasteners like 1" nails or staples to affix anchor materials together.
- 3. Anchor methods may vary. In the absence of supplier recommendations, generic methods may include materials such as:
 - a. Rope, tie, or straps made from natural fibers like jute, coir, or cotton.
 - b. Wooden stakes (minimum 2"x2") or poles (minimum 3" diameter).
 - c. Small metal fasteners like 0.5" staples or 1" nails.

2.03 WATER

- A. Contractor shall provide water for plantings for the duration of the construction period.

2.04 SOIL AMENDMENTS, FERTILIZERS, MULCHING

A. Topsoil

- 1. Coordinate with Section 32 91 19.13 – Topsoil Placement and Grading

B. Fertilizers

- 1. Fertilizer shall not be used within the limits of the floodplain

C. Herbicides

SECTION 32 93 00 – PLANTS

1. Herbicides or poison of any kind shall not be used during construction unless directed by the Hydraulic Engineer to manage invasives not fully removed during clearing and grubbing.

D. Mulch

1. Woven coir mulch mat/disc/ring at least 1” thick, or with layers stacked until at least 1” thick. May also be used to cover a thin mulch layer below, in coordination with 2.02 D-2 below.
2. Coordinate with Section 01 57 13 – Temporary Erosion and Sediment Control. Mulch shall be clean, untreated, free from invasive and non-native species.

PART 3 - EXECUTION

3.01 GENERAL

- A. Contractor shall employ competent personnel able to complete proper installation with plants as described in this section and in the Drawings.
- B. Planting shall only be done when weather and soil conditions permit and within practical or specified growing seasons for each species, unless directed otherwise by Hydraulic Engineer or a Plant Ecologist.
- C. Plan and coordinate planting as part of the overall construction sequence. Once the floodplain is restored along with the upland retaining wall, access will only be by foot – installation and maintenance will be more difficult.
- D. Container stock shall be planted in the same growing season in which they were dug.

3.02 PREPARATION

- A. Hydraulic Engineer or an otherwise Designated Supervisor (Plant Ecologist, Biologist, Landscape Architect, etc.) shall observe and approve planting materials prior to purchase and installation. This shall be coordinated subsequent Hydraulic Engineer approval of material submittals for this Section, and may commence at the nursery or site.
- B. Hydraulic Engineer shall verify plant quantities and diversity as well as the planting plan proposed by the Contractor. Hydraulic Engineer or Designated Supervisor shall inspect the site or in incremental sections as they are in a final condition to be planted. This implies that prior conditions have been satisfied.
- C. Flag or mark subsurface conditions such as low depth to bedrock so plants can be located properly. Flag or mark locations for plants to better create a heterogeneous/random pattern (coordinate with 3.03 below).

3.03 PLACEMENT

- A. All plants shall be placed mimicking natural settings, planted in a random fashion and not on a grid, intermixing species and densities.

3.04 INSTALLING

- A. Install all plants according to suppliers specifications. In the absence of supplier specifications, install:
 1. Container stock so top of root ball is level with the surrounding ground, with the plant aligned vertically.
 2. Livestakes set 2/3 the length of the plant into a pre-made hole, then tamp down the ground around the plant.

SECTION 32 93 00 – PLANTS

3. Water all plants for the duration of construction and set up a watering plan until all vegetation has fully rooted.

3.05 ANCHORING AND PROTECTING

- A. Anchor methods may vary. In the absence of supplier recommendations, generic methods may include:
 1. 2-5 gallon container stock: Use two 2"x2"x24" notched wooden stakes hammered at least 20" into the ground at slight angles leaning away from the plant on opposite sides. Wrap rope around plant, pulled to eliminate slack but not tight around, and tie off at stake.
 2. 15 gallon container stock: Use three 2"x2"x36" notched wooden stakes hammered at least 24" into the ground at slight angles leaning away from the plant, at even 120 degree intervals around the plant.
 3. All container stock: As this is a floodplain and inundation is expected, placing mulch over the installed root ball of plants may not last. Instead, place one or more woven coir disc/mat/rings in place of mulch to a depth of at least 1" and affix to ground using small biodegradable anchors.

END OF SECTION

TABLE OF CONTENTS

**Brownfields Cleanup
Former Woods Woolen Mill
23-25 West Mill Street, Hillsborough, New Hampshire
NHDES Site #: 199909015**

BIDDING REQUIREMENTS

Invitation to Bid
Instructions to Bidders
Bid Form
Bidders Information Form
Bid Schedule
Available Information

CONTRACTING

Notice of Award
Construction Agreement
Payment Bond
Performance Bond
Notice to Proceed
Contractor's Affidavit
Contractor's Release
Application for Payment
Change Orders
Certificate of Substantial Completion
Certificate of Authority
General Conditions

ATTACHMENTS

Construction Design Drawings
Technical Specifications

BIDDING REQUIREMENTS

Invitation to Bid

INVITATION TO BID
Riparian Floodplain Restoration
Former Woods Woolen Mill
23-25 West Mill Street, Hillsborough, New Hampshire
Engineer's Project #: 2024-013

Separate and sealed Bids for the floodplain restoration at the Former Woods Woolen Mill site located in Hillsborough, New Hampshire will be received by Streamworks, PLLC. (Streamworks), the Engineer, by **Friday, January 9, 2026 at 5:00 PM**. A second Invitation to Bid has been issued by Sanborn Head & Associates, Inc. (Sanborn Head) for Brownfields cleanup for a portion of the site. Contractor will need to prepare a separate bid for Sanborn Head's Contract. Both Contracts are subject to the Drawings and Specifications prepared by the respective firms. Both Contracts will make up the entirety of the Project.

A Mandatory Pre-Bid Meeting associated with both Contracts will be held at the Work site on Monday, December 15, 2025, at 10:00 AM.

The Project has been split into two Contracts, each of which are being funded through separate sources. The floodplain restoration work will be contracted with the Town of Hillsborough, NH (Town). The floodplain restoration Contract that is the subject of this Invitation to Bid is being led by the Town's authorized agent, Streamworks, PLLC. and funded through NHDES Aquatic Mitigation Funds. The Sanborn Head Contract covering brownfields cleanup (a separate bid) is being led by the New Hampshire Department of Environmental Services (NHDES; the Owner) and funded through NHDES Brownfields Cleanup Grants. The Owners are completing this work to promote future redevelopment of the Brownfields site.

The work being completed under the Town's Contract includes, but is not limited to, the following major items:

- Mobilizing and demobilizing materials, equipment, and personnel required to complete the Work;
- Excavating select areas following brownfields cleanup excavation where rubble, retaining wall, concrete, and bedrock remain on-Site;
- Transporting and disposing of the following waste at appropriately permitted, Streamworks-approved, off-site disposal facilities: wood and vegetation from grubbing activities (most importantly, invasive species removal), rubble/wall/concrete/bedrock from within project excavation areas, and accumulated sediment and erosion control;
- Construction of the floodplain within the footprint of the former mill building including soil stabilization measures;
- Planting, seeding, and installing habitat features on the restored floodplain;
- Staging and stockpiling of materials within appropriate lands;
- Erosion and sediment control installation, inspection, and maintenance including all appropriate intermediate means (installing and removing when/where necessary to control erosion around the site);
- Removing, rebuilding, and/or reinforcing granite masonry retaining walls; and

- Scheduled and required documentation, reporting, and meetings.

The Bid package includes a Bid Schedule for the Work completed under the Town's Contract. For the purposes of the bid, assume that the work will begin in Spring 2026. Brownfields cleanup work by Sanborn Head is expected to be performed concurrently with floodplain restoration activities. A separate Bid Schedule associated with the remediation work will be required as part of Sanborn Head's Contract.

Following the Pre-Bid Meeting, should a Bidder wish to re-visit the site to verify conditions, or in the event they missed the Pre-Bid Meeting, the Bidder may make such a request to Streamworks, provided that the request is made in writing. All site visits pertaining to the Town's Contract should be coordinated through Streamworks.

Each general Bid shall be submitted in accordance with the Instructions to Bidders.

Each Bid must be accompanied by a Certificate of Existence from the New Hampshire Secretary of State.

No Bidder may withdraw a Bid within 60 calendar days after the actual date of opening thereof.

The successful Bidder must furnish 100% Performance and Payment Bonds with a surety company acceptable to the Town. The successful Bidder will be required to execute the Contract Agreement within 10 business days following notification of the acceptance of his Bid.

Streamworks reserves the right to waive any informality in, or to reject any or all Bids, if deemed to be in the best interest of the Owner.

Time required for the Contractor to achieve substantial completion for the project will be within 90 calendar days from the date of mobilization, which shall be in Spring 2026.

Liquidated damages for substantial completion of the work will be in the amount of \$1,500.00, made payable to the Town of Hillsborough, NH, for each calendar day of delay from the date established for substantial completion.

All questions regarding this Bid should be directed to Streamworks:

Joel Ballestero (Streamworks, PLLC)
jballestero@streamworkspllc.com
970-556-7552

Instructions to Bidders

INSTRUCTIONS TO BIDDERS

**Riparian Floodplain Restoration
Former Woods Woolen Mill
23-25 West Mill Street, Hillsborough, New Hampshire
Engineer's Project #: 2024-013**

Bids will be received by the Town of Hillsborough, NH (herein called the "Owner" or "Town") and the Owner's authorized representative, Streamworks, PLLC. (herein called the "Engineer" or "Streamworks") until **Friday, January 9, 2026 at 5:00 PM**. Contractor will need to prepare a separate bid for Sanborn, Head & Associates, Inc.'s (herein called "Sanborn Head") Contract which includes brownfields cleanup for a portion of the site, with both the Town's and Sanborn Head's Contracts being subject to the Drawings and Specifications prepared by the respective firms.

Bids for the remediation contract must be submitted electronically via email to Laura Buono at laura@hillsboroughnh.net (Owner), and Joel Ballestero at jballestero@streamworkspllc.com (Engineer). The email must be received by the time indicated above. Bids received by email after this time will not be accepted.

All Bids must be made on the required Bid Form. All blank spaces for Bid prices must be filled in, in ink or typewritten, and the Bid form must be fully completed and executed when submitted.

Streamworks may waive any informalities or minor defects or reject any and all Bids. Any Bid may be withdrawn prior to the above scheduled time for the opening of Bids or authorized postponement thereof. Any Bid received after the time and date specified shall not be considered. No Bidder may withdraw a Bid within 60 days after the actual date of the opening thereof. Should there be reasons why the contract cannot be awarded within the specified period.

Bidders must satisfy themselves of the accuracy of the estimated quantities in the Bid Schedule by examination of the site and a review of the Design Drawings and Technical Specifications including Addenda. After Bids have been submitted, Bidder shall not assert that there was a misunderstanding concerning the quantities of Work or of the nature of the Work to be done.

All questions about the meaning or intent of the Contract Documents shall be submitted to Streamworks in writing via email **by 5PM on December 18, 2025**. All replies that alter the intent of the Contract Documents will be issued by Addenda electronically delivered to all parties attending the Pre-Bid Meeting, and will be posted on the Town's website **on December 22nd**.

Should a Bidder find discrepancies in and/or omissions from the Contract Documents or should a Bidder be in doubt as to their meaning, they shall notify Streamworks in writing via email **by 5PM on December 18th**. All replies that alter the intent of the Contract Documents will be issued by Addenda electronically delivered to all parties attending the Pre-Bid Meeting, and will be posted on the Town's website **on December 22nd**.

The Contract Documents contain the provisions required for the construction of the Work. Information obtained from an officer, agent, or employee of Streamworks or any other person shall not affect the risks or obligations assumed by Contractor or relieve them from fulfilling any of the conditions of the Contract Documents.

A Performance Bond and a Payment Bond, each in the amount of 100 percent of the Contract Price, with a corporate surety approved by Streamworks, will be required for the faithful performance of the contract.

Attorneys-in-fact who sign Payment Bonds and Performance Bonds must file with each Bond a certified and effective dated copy of their power of attorney.

Within seven (7) calendar days from the date when Notice of Award is delivered to Bidder, the party to whom the contract is awarded will be required to deliver to the Streamworks and the Town the executed Agreement and the Performance Bond and Payment Bond. The Notice of Award shall be accompanied by the necessary Agreement and Bond forms.

The Notice to Proceed shall be issued within seven (7) days execution of the Agreement between Contractor and Owner (Town). Should there be reasons why the Notice to Proceed cannot be issued within such period, the time may be extended by mutual agreement between Streamworks and Contractor. If the Notice to Proceed has not been issued within the seven (7) day period or within the period mutually agreed upon, Contractor may terminate the Agreement without further liability on the part of either party.

Streamworks may make such investigations as deemed necessary to determine the ability of Bidder to perform the Work, and Bidder shall furnish to Streamworks all such information and data for this purpose as Streamworks may request. Streamworks reserves the right to reject any Bid if the evidence submitted by, or investigation of, such Bidder fails to satisfy Streamworks that such Bidder is properly qualified to carry out the obligations of the Agreement and to complete the Work contemplated therein.

Streamworks may reject any bid not prepared and submitted in accordance with the provisions hereof and may waive any informalities or reject any and all bids deemed to be in the best interest of Owner. Streamworks may also reject bids which in its sole judgment are incomplete, conditional, obscure or not responsive or which contain additions not called for, erasures not properly initialed, alterations, or similar irregularities; or Streamworks may waive such omissions, conditions or irregularities.

A conditional or qualified Bid will not be accepted. However, alternatives to required Bid Items will be considered as additional or alternate items provided they are in addition to responding to the required Bid Items.

All applicable laws, ordinances, and the rules and regulations of all authorities having jurisdiction over construction of the Project shall apply to the contract throughout.

Each Bidder is responsible for inspecting the site and for reading and being thoroughly familiar with the Contract Documents. The failure or omission of any Bidder to do any of the foregoing shall in no way relieve any Bidder from any obligation in respect to its Bid. Furthermore, the Bidder is responsible for ensuring the site foreman who will be overseeing implementation of the project fully understands the scope and details listed within the 100% Design Drawings and Technical Specifications prior to the start of construction.

Bidder shall supply the names and addresses of major material Suppliers and all Subcontractors when requested to do so by Streamworks.

MANDATORY PRE-BID MEETING

A Mandatory Pre-Bid Meeting will be held at the Former Woods Woolen Mill site located at 23-25 West Mill Street in Hillsborough, New Hampshire on Monday, December 15, 2025 at 10:00 AM.

Representatives of Streamworks and Sanborn Head (separate Contract) will be present to discuss the Project. Information presented at the pre-Bid Meeting does not alter the Contract Documents.

Requests for interpretation of the Contract Documents at the Pre-Bid Meeting should be submitted in writing to the Streamworks. All questions that may alter the intent of the Contract Documents will be answered by Addenda, mailed or delivered to all parties attending the Pre-Bid Meeting, and posted on the Town's website.

FOLLOW-UP PRE-BID MEETINGS

Following the Pre-Bid Meeting, should a Bidder wish to visit the Work site to verify/confirm site conditions, or in the event they were unable to attend the Pre-Bid Meeting, Bidder may make such a request to Streamworks, provided that the request is made in writing. All site visits for Streamworks' Contract will be coordinated through Streamworks.

BIDDERS INFORMATION FORM

To demonstrate qualifications for the Contract, each Bidder must be prepared to submit written satisfactory evidence that they have sufficient experience, necessary capital, materials, machinery, and skilled workmen to complete the Contract. Streamworks' decision or judgment on these matters shall be final, conclusive, and binding.

To assist Streamworks in such investigations and determinations, Bidders will be required to submit to Streamworks a completed copy of Bidder's Information Form as part of the bid package. This form is available as part of these bound Contract Documents.

Financial statements to be submitted with Bidder's Information Form shall be of such date as Streamworks shall determine and shall include Bidder's latest balance sheet and income statement showing current assets, net fixed assets, other assets, current liabilities, and other liabilities.

BID FORM

Bid Forms must be completed in ink or typewritten. The Bid price of each item on the form must be stated in words and numerals. In case of a conflict, words will take precedence.

Bids by corporations must be executed in the corporate name by the president or vice president and corporate seal shall be affixed and attested to by the secretary. The corporate address and state of incorporation shall be shown below the signature.

All names must be typed or printed below the signature.

The Bid shall contain an acknowledgment of receipt of all Addenda.

CONTRACTOR EXPERIENCE

Contractor shall demonstrate that it and its subcontractor(s) have sufficient ability and the experience, financial capability, safety record and equipment necessary in this class of work, and sufficient capital, plant, and equipment to satisfactorily and successfully carry out the Work as shown and specified in the Contract Documents. As a minimum, Contractor must demonstrate it has successfully completed a minimum of three (3) projects of similar type in the last five (5) years. Contractor shall submit the information required with the Bid. If Streamworks determines this submittal is incomplete, the Bid shall be considered incomplete and the Bid shall be rejected.

SUBCONTRACTORS

Contractor shall not award Work to Subcontractor(s) where the combined value of all subcontracted Work exceeds 50% of the Contract Price, not including transportation and disposal of remediation waste.

SAFETY AND HEALTH REGULATIONS

This project is subject to all of the Occupational Safety and Health Regulations (CFR 29 Part 1926, CFR 29 Part 1910.120, and all subsequent amendments) as promulgated by the U.S. Department of Labor on June 24, 1974. Contractors are urged to become familiar with the requirements of these regulations.

OVERHEAD, SURFACE AND SUB-SURFACE INVESTIGATIONS

The information presented in the Contract Documents was collected by Streamworks for their own use in preparing documents for the remediation of the site and for guidance in preparing engineering design and are shown on the plans and provided in the appendices. The accuracy and completeness of the data is not guaranteed. Contractor is responsible for assuming all risk in any and all excavation Work. Contractor is required to examine the best sources available and visit the site to assure themselves of the project conditions.

INSURANCE

Contractor shall possess insurance in the types and limits described in the Contract Documents. Bidders shall provide sample Certificates of Insurance as part of the Bid Package and effective Certificates of Insurance upon notification of Contract Award. Said certificates shall name Owner (Town of Hillsborough) and Engineer (Streamworks, PLLC., [Streamworks]) as additional insured parties and shall state that there are no pollution exclusions.

Failure of Bidder to provide confirmation of insurance coverage limits with their bid subjects bid to disqualification. Failure of Contractor to maintain the required insurance policies in force during the Work covered by the Contract Documents shall constitute a breach of the Contract, and Owner shall have the right, in addition to any other rights, to immediately cancel and terminate this agreement without further cost to Owner.

CONFLICT OF INTEREST

Contractor shall notify Streamworks of any actual, apparent, or potential conflict of interest regarding any individual working on a contract assignment or having access to information regarding the contract. This notification shall include both organizational conflicts of interest and personal conflicts of interest. If a personal conflict of interest exists, the individual who is affected shall be disqualified from taking part in any way in the performance of the assigned Work that created the conflict of interest situation.

COPIES OF THE CONTRACT

Executed copies of the Contract Documents will be distributed electronically to the Town and Contractor by Streamworks.

NON-RESIDENT CONTRACTORS

The successful Bidder, if a corporation established under laws other than the State of New Hampshire, shall file, at the time of the execution of the contract, with Streamworks, notice of the name of its resident attorney, appointed as required by the laws of the State of New Hampshire.

The successful Bidder, if not a resident of New Hampshire, and not a corporation, shall file, at the time of execution of the contract, with Streamworks, a written appointment of a resident of the State of New Hampshire, having an office or place of business therein, to be their true and lawful attorney upon whom all lawful processes in any actions or proceedings against them may be served; and in such writing, which shall set forth said attorney's place of residence, shall agree that any lawful process against them which is served on said attorney shall be of the same legal force and validity as if served on them and that the authority shall continue in force so long as any liability remains outstanding against them in New Hampshire. The power of attorney shall be filed in the office of the Secretary of State if required, and copies certified by the Secretary shall be sufficient evidence thereof. Such appointment shall continue in force until revoked by an instrument in

writing, designating in a like manner some other person upon whom such processes may be served, which instrument shall be filed in the manner provided herein for the original appointment.

A Non-resident Contractor shall be deemed to be:

1. A person who is not a resident of the State of New Hampshire.
2. Any partnership that has no member thereof resident of the State of New Hampshire.
3. Any corporation established under laws other than those of the State of New Hampshire.

BIDDERS QUALIFICATIONS

No award will be made to any Bidder who cannot meet all of the following requirements:

1. Bidder shall not have defaulted nor turned the Work over to the bonding company on any contract within three years prior to the Bid date.
2. Bidder shall maintain a permanent place of business.
3. Bidder shall have adequate personnel and equipment to perform the Work expeditiously.
4. Bidder shall have suitable financial status to meet obligations incidental to the Work.
5. Bidder shall have appropriate technical experience satisfactory to Owner and Streamworks in the class of Work involved.
6. Bidder shall be registered with the Secretary of State to do business in New Hampshire.
7. Bidder shall not have failed to complete previous contracts on time, including approved time extensions.

INSURANCE CERTIFICATES

No Work will be permitted on the site until the required and current Insurance Certificates are supplied.

WITHDRAWAL OF BIDS

The attention of Bidders is directed to the fact that, in submitting their Bid, Bidder agrees that they will not withdraw their Bid within 60 consecutive calendar days after the actual date of the opening of Bids.

Prior to Bid opening, Bids may be withdrawn upon written or electronic request of Bidder provided confirmation of any electronic withdrawal over the signature of Bidder is placed in the mail and

postmarked prior to the time set for Bid opening. Bid documents and security of any Bidder withdrawing their Bid in accordance with the foregoing conditions will be returned.

ADD-ON WORK

The attention of Bidders is directed to the fact that additional cleanup work tasks may be added to the Contract with the written approval of Streamworks and Contractor.

Bid Form

BID FORM

**Riparian Floodplain Restoration
Former Woods Woolen Mill
23-25 West Mill Street, Hillsborough, New Hampshire
Engineer's Project #: 2024-013**

To: **Streamworks, PLLC.** (hereinafter called "Engineer" or "Streamworks"):

Proposal of _____ (hereinafter called "Bidder"), organized and existing under the laws of the State of _____ doing business as _____
(Corporation, Partnership, Individual)

In compliance with your Advertisement, Bidder hereby proposes to perform all Work for the construction of: **Former Woods Woolen Mill Floodplain Restoration** in strict accordance with the Contract Documents, within the time set forth therein, and at the prices presented in the Bid Schedule.

By submission of this Bid, each Bidder certifies, and in the case of a joint Bid each party thereto certifies as to their own organization, that this Bid has been arrived at independently, without consultation, communication, or agreement as to any matter relating to the Bid with any other Bidder or with any competitor.

Bidder hereby agrees to commence Work under this contract on or before a date to be specified in the Notice to Proceed and to complete the Project within 60 calendar days from the date specified in the "Notice to Proceed."

Liquidated damages for substantial completion of the work will be in the amount of \$1,500.00 for each calendar day of delay from the date established for substantial completion.

- A. The undersigned Bidder proposes and agrees, if this Bid is accepted, to enter into an agreement with the Town of Hillsborough, NH (Town) in the form included in the Contract Documents to perform and furnish all Work as specified or indicated in the Contract Documents for the Bid price and within the Bid times indicated in this Bid and in accordance with the other terms and conditions of the Contract Documents.
- B. Bidder accepts all of the terms and conditions of the Invitation to Bid and Instructions to Bidders, including without limitation those dealing with the disposition of Bid security. This Bid will remain subject to acceptance for sixty (60) days after the Notice of Award. Successful Bidder will sign and deliver the required number of counterparts of the Agreement with the Bonds and other documents required by the Bid requirements within seven (7) days after the date of Streamworks' Notice of Award.

C. In submitting this Bid, Bidder represents, as more fully set forth in the Agreement, that:

- a. Bidder has examined and carefully studied the Bid Documents and the following Addenda, receipt of which is hereby acknowledged: (List Addenda by Number and Date):

- b. Bidder has become familiar with and is satisfied as to the general, local and site conditions that may affect cost, progress, performance and furnishing of the Work.
- c. Bidder is familiar with and is satisfied as to all federal, state and local Laws and Regulations that may affect cost, progress, performance and furnishing of the Work.
- d. The submission of this Bid constitutes an incontrovertible representation by Bidder that without exception the Bid is premised upon performing and furnishing the Work required by the Contract Documents and such means, methods, techniques, sequences or procedures of construction as may be indicated in the Contract Documents, and that the Contract Documents are sufficient in scope and detail to indicate and convey understanding of all terms and conditions for performance and furnishing of the Work.
- e. Bidder has correlated the information known to Bidder, information and observations obtained from visits to the site, reports and drawings identified in the Contract Documents and all additional examinations, investigations, explorations, tests, studies and data with the Contract Documents.
- f. Bidder has given Streamworks written notice of all conflicts, errors, ambiguities or discrepancies that Bidder has discovered in the Contract Documents and the written resolution thereof by Streamworks is acceptable to Bidder, and the Contract Documents are generally sufficient to indicate and convey understanding of all terms and conditions for performing and furnishing the Work for which this Bid is submitted.
- g. This Bid is genuine and not made in the interest of or on behalf of any undisclosed person, firm or corporation and is not submitted in conformity with

any agreement rules of any group, association, organization or corporation; Bidder has not directly or indirectly induced or solicited any other Bidder to submit a false or sham Bid; Bidder has not solicited or induced any person, firm or corporation to refrain from bidding; and Bidder has not sought by collusion to obtain for itself any advantage over any other Bidder or over Streamworks.

- D. Bidder will complete the Work in accordance with the Contract Documents for the following Base Bid price:

TOTAL BASE BID PRICE

_____ dollars (\$ _____)
(words) *(figures)*

NOTE: Bids shall include sales tax and all other applicable taxes and fees.

- E. The Base Bid breakdown is set forth in the Bid Schedule. If increases or decreases in these quantities occur, the Contract Price is to be adjusted on the basis of the unit prices provided in the Schedule of Values. Bidder acknowledges that quantities of work are not guaranteed and final payment will be based on actual quantities determined as provided in the Contract Documents.
- F. Contractor shall furnish a 100 percent Performance Bond and a 100 percent Payment Bond each in the amount of the Lump Sum Base Bid.
- G. Bidder also proposes to perform alternate work as herein stated resulting in additions or deductions on the Base Bid proposal above and providing a breakdown of alternate prices in the Base Bid breakdown. Additions or deductions shall include the cost of modification of work or additional work that Bidder may be required to perform by reason of Streamworks' acceptance of the alternate.
- H. Bidder agrees that the Work will be substantially completed and ready for final payment on or before the date indicated in the Agreement.
- I. Bidder accepts the provisions of the Agreement as to liquidated damages in the event of failure to complete the Work within the time specified in the Agreement.

- J. The following documents are attached to and made a condition of this Bid:
 - a. A tabulation of Subcontractors, Suppliers and other persons and organizations required to be identified in this Bid.
 - b. Bid Schedule.
 - c. A photocopy of Contractor's License.
- K. Communications concerning this Bid shall be addressed to:

To:

Mrs. Laura Buono
laura@hillsboroughnh.net

And:
Mr. Joel Ballestero
jballestero@streamworkspllc.com

- L. Terms used in this Bid which are defined in the General Conditions or Instructions, will have the meanings indicated in the General Conditions or Instructions.

SUBMITTED on _____, 20____

State Contractor License No. _____(if applicable)

IF BIDDER IS:

An Individual

By _____
(Name)

doing business as _____

Business address: _____

Telephone No: _____

A Partnership

By _____
(Firm Name)

General Partner _____

(SEAL)

Business address: _____

Telephone No: _____

A Corporation

By _____
(Corporation Name)

Incorporated in the State of _____
(State of Incorporation)

(CORPORATE
SEAL)

By: _____
(Name of person authorized to sign)

(Title)

Attest: _____
(Secretary)

Business address: _____

Telephone No: _____

Date of Qualification to do Business is: _____

A Joint Venture

By _____
(Name 1)

Business address: _____

By _____
(Name 2)

Business address: _____

Official Communication Should Be Addressed to: _____

Telephone No: _____

(Each joint venturer must sign. The manner of signing for each individual, partnership and corporation that is a party to the joint venture should be in the manner indicated above).

Being duly sworn, _____
(Name) **deposes and says that he is of**

_____ **and that the answers to the foregoing**
(Company)

questions and all statements contained therein are true and correct.

Sworn to before me this _____ day of _____, 20 _____

By: _____
(Notary Public)

My Commission Expires: _____

Bidder's Information Form

BIDDERS INFORMATION FORM

**Riparian Floodplain Restoration
Former Woods Woolen Mill
23-25 West Mill Street, Hillsborough, New Hampshire
Engineer's Project #: 2024-013**

Bidder is requested to state below what Work of a similar character to that included in the proposed contract they have done to give references that will enable Streamworks to judge Bidder experience, skill, and business standing.

All questions must be answered and the data given must be clear and comprehensive. This statement must be notarized. If necessary, add separate sheets.

1. *Name of Bidder:* _____

2. *Permanent Main Office address:*

3. *When organized?* _____

4. *Where incorporated?* _____

5. *Is Bidder registered with the Secretary of the State to do business in New Hampshire?* ___(Yes) ___(No).

6. *How many years have you engaged in the contracting business under your present firm name?* _____

Also state names and dates of previous firm names, if any.

7. *General character of Work performed by your company:*

8. *Have you ever failed to complete any Work awarded to you in the scheduled contract time, including approved time extensions? __ (Yes) __ (No).
If so, where and why?*

9. *Have you ever defaulted on a contract? __ (Yes) __ (No).
If so, where and why?*

10. *Have you ever had liquidated damages assessed on a contract?
__ (Yes) __ (No). If so, where and why?*

11. *List the three (3) largest contracts executed by your company within the last three (3) years, stating approximate cost for each, and the month and year completed. Include references and points of contact.*

12. *List three projects similar to the project in the last five years, stating approximate cost for each and the month and year completed, with references including point of contact:*

13. *List your major equipment available for this contract:*

14. *List your key personnel such as Project Superintendent and foreman available for this contract and attach their resume to this bid:*

15. *List any subcontractors and their scope whom you would expect to use for the project (unless this Work is to be done by your own organization):*

Bid Schedule

BID SCHEDULE

**Riparian Floodplain Restoration
Former Woods Woolen Mill
23-25 West Mill Street, Hillsborough, New Hampshire
Engineer's Project #: 2024-013**

This Bid Schedule separates the Work associated with the Town's Contract (Streamworks' floodplain restoration work) portion of this Project into measurable units for payment purposes. A separate Bid Schedule associated with Sanborn Head's Brownfields remediation Work will be prepared as part of their contract under separate cover.

Pay items shall be paid using the units and unit prices indicated on the Bid Schedule. Payment shall be full compensation for all labor, materials, services, equipment, tools, taxes, overhead and profit, transportation, and disposal required to complete the Work described under each pay item. Payment shall be made in accordance with the general terms and conditions of the Contract. Contractor shall be entirely responsible for performing all Work described in the Contract Documents, whether or not specifically or fully described on this Bid Schedule. For the purposes of the bid, assume that work will begin in Spring 2026.

Payment will not be made for quantities that exceed the stated quantities in the Bid Schedule, unless additional quantities are approved in writing by Engineer. Payment for lump sum items will be based on a percent complete basis, as determined by Engineer-approved contractor invoices for payment.

The following Bid Schedule shall be completed in ink or typewritten. The Bidder agrees to perform all the work described in Streamworks' Contract Documents for the following lump sum and unit prices.

BASE BID

PAY ITEM NO. AND DESCRIPTION		ESTIMATED QUANTITY		UNIT PRICE (\$/UNIT)		ITEM PRICE (\$)
1	Submittals and Permits	1	LS		LS	
2	Site Mobilization and Demobilization	1	LS		LS	
3	Erosion Control and Stabilization (Floodplain)	1	LS		LS	
4	Clearing, Grubbing, and Vegetation/Tree Removal	1	LS		LS	
5	Flow Diversion and Dewatering	1	LS		LS	
6	Establish, Maintain, and Remove all Access Paths and Perimeter Fencing	1	LS		LS	
7	Excavation, Disposal and/or Temporary Stockpiling of Materials					
	7A. Bedrock	371	CY		CY	
	7B. Concrete	453	CY		CY	
	7C. Rubble	222	CY		CY	
	7D. Granite Masonry Rock Wall	40	CY		CY	
8	Rebuilding and Reconstructing Retaining Walls					
	8A. Riverside Retaining Wall Reinforcement	1200	SF		SF	
	8B. Upland Retaining Wall Reinforcement	2000	SF		SF	
	8C. Upland Retaining Wall Reconstruction	1	LS		LS	
9	Topsoil Backfill and Grading	195	CY		CY	
10	Soil Stabilization	21,100	SF		SF	
11	Planting and Seeding					
	9A. Seeding	14,500	SF		SF	
	9B. Low Floodplain Plants	125	EA		EA	
	9C. High Floodplain Plants	50	EA		EA	
	BASE BID TOTAL (Figures)					
	BASE BID TOTAL (Words)					
12	Contingency – Bedrock and Concrete Excavation and Disposal	80	CY		CY	

The Work to be done and paid for under any item shall not be limited to the exact extent mentioned or described herein, but rather, shall include all incidental work necessary or customarily needed for the completion of that item at no additional cost to Owner.

BID ITEM DEFINITIONS

ITEM 1: SUBMITTALS AND PERMITS

This item shall include the cost for preparation and completion of all submittals (refer to Section 01 33 00), and costs for obtaining permits and/or submitting necessary notifications applicable to the work, including payment of permit fees as needed. Determination of the permitting and notification requirements for the Work is the responsibility of Contractor. At a minimum, the permits and notifications anticipated to be required as part of Streamworks' Scope of Work include the NPDES Construction General Permit (CGP) Notice of Intent (NOI) and weekly inspections to be completed post-construction in accordance with the requirements of the Stormwater Pollution Prevention Plan (SWPPP) to be completed for the site under the CGP.

Refer to Section 01 33 00 – Submittals Procedures for a list of required submittals. Required submittals include all close-out documentation.

Payment for this item will be made on a lump sum basis.

ITEM 2: SITE MOBILIZATION AND DEMOBILIZATION

This item shall include the cost for mobilization and demobilization of all equipment, materials, temporary facilities, and labor necessary to perform the Work. Specific work under this item shall also include:

- Clearance of underground utilities;
- Provision of temporary utilities and facilities (e.g., portable toilet);
- Maintenance of perimeter fencing and/or repairing the existing perimeter fencing as needed (refer to Section 01 50 00 – Temporary Facilities and Controls); and
- Clean-up of the site upon completion of work, including restoration of areas disturbed by the Work outside of the floodplain restoration areas.

ITEM 3: EROSION CONTROL AND STABILIZATION (FLOODPLAIN)

This item requires Contractor to furnish all labor, equipment, and materials necessary to install and maintain erosion and sedimentation control devices in accordance with Section 01 57 13 – Temporary Erosion and Sediment Controls related to the Remediation portion of the Contract. Erosion and sediment controls shall be installed prior to clearing and grubbing activities.

This work includes the installation of wood chip berms and (if necessary) a turbidity curtain in accordance with the Specifications and Drawings. Erosion and sediment control devices shall be maintained by Contractor throughout the course of construction activities with weekly inspection to see if maintenance of the features is required. If needed, accumulated sediment shall be removed when it reaches six inches (max depth), and disposed of or spread out over unfinished lands. After excavation and removal of impacted materials from the site and construction of the caps are completed and erosion and sediment control devices are no longer necessary, dispose of all accumulated sediment. Wood chip berms may be spread in a thin layer across the site or disposed of. Erosion control measures associated with the Brownfields cleanup portion of the Work are covered under Sanborn Head's Bid Schedule and should not be included under this Pay Item.

ITEM 4: CLEARING, GRUBBING, AND VEGETATION/TREE REMOVAL

This item requires Contractor to furnish all labor, equipment, and materials necessary to clear and grub the remaining site within the work area outside the Brownfields remediation Work, (estimated to be about 775 square feet) in accordance with the Drawings and Specifications. The Contractor shall remove from the site and transport to an approved facility any material generated during this item, which also includes invasive species such as Japanese Knotweed (refer to Section 31 11 00 – Clearing and Grubbing). Payment will be on a lump sum basis and will be made once the materials have been removed from the site.

ITEM 5: FLOW DIVERSION AND DEWATERING

This item requires Contractor to furnish all labor, equipment, and materials necessary to install, maintain, and remove flow diversion measures as detailed in the Drawings as well as (if necessary) performing minimal dewatering in accordance with Section 31 23 19 – Dewatering. Flow diversion includes installation of a berm at the south end of the project to ensure floodwaters do not enter the site. Dewatering is expected to be minor, most likely necessary at the south and north ends before backfilling, though may be necessary following a rain event. Payment will be on a lump sum basis and may be paid as a percentage of the total as the project progresses, or in full after these measures are no longer necessary.

ITEM 6: ESTABLISH, MAINTAIN, AND REMOVE ALL ACCESS PATHS AND PERIMETER FENCING

This item requires the Contractor to furnish all labor, equipment, and materials necessary to establish, maintain, and remove access roads. Access paths shall be constructed as specified in Section 31 20 00 – Earth Moving, and in accordance with the Design Drawings.

The work shall also include the removal of the temporary access roads by the Contractor upon completion of construction activities and return of the area (if applicable) to its pre-construction conditions (refer to Section 02 61 013 – Excavation and Handling of Contaminated Materials).

This work also includes the maintenance and/or repair of perimeter fencing currently surrounding the site.

Payment will be on a lump sum basis. Fifty percent of this payment item will be paid as part of the initial progress payment. The remainder will be paid when they are removed after Final Completion of the work has been approved by Streamworks.

ITEM 7: EXCAVATION, DISPOSAL AND/OR TEMPORARY STOCKPILING OF MATERIALS

This item requires the Contractor to furnish all labor, equipment, and materials necessary to excavate and dispose of bedrock, concrete, rubble, and granite masonry wall rocks in coordination with Section 31 20 00 Earth Moving. Excavation of soils is included in the Brownfields cleanup Contract with Sanborn Head. This item will also include the selective

stockpiling of large rocks/boulders to be reused – either buried on-site or used to rebuild or reinforce the existing retaining walls. All concrete, bedrock, and rubble not consisting of rock shall be disposed of offsite. The pay item is broken down into the following subtasks:

Item 7A: This item requires the Contractor to furnish all labor, equipment, and materials necessary to excavate and dispose of bedrock within the required limit of backfill for the floodplain restoration. Bedrock outcrops are visible all around the site and surrounding lands, having highly irregular topography. Borings were done at the site to help understand subsurface conditions, but Contractor should be prepared to perform more or less removal for this task. Item 12 includes a Contingency for bedrock and concrete excavation and removal beyond the quantities shown in this Bid Schedule. Payment for this subtask shall be on a unit price basis.

Item 7B: This item requires the Contractor to furnish all labor, equipment, and materials necessary to excavate and dispose of concrete foundation within the required limit of backfill for the floodplain restoration. Concrete foundation is visible at and above the existing site ground but the depth of each is unknown. Item 12 includes a Contingency for bedrock and concrete excavation and removal beyond the quantities shown in this Bid Schedule. Payment for this subtask shall be on a unit price basis.

Item 7C: This item requires the Contractor to furnish all labor, equipment, and materials necessary to excavate and dispose of rubble within the required limit of backfill for the floodplain restoration. Rubble primarily consists of large rocks, boulders, and granite blocks which existed in the former mill building foundation and walls. Some of this material shall be selectively chosen to be stockpiled and reused to rebuild and reinforce the two retaining walls (Item 8). Rubble also consists of bricks, metal, loose concrete, and other anthropogenic materials all of which shall be disposed of offsite. Payment for this subtask shall be on a unit price basis.

Item 7D: This item requires the Contractor to furnish all labor, equipment, and materials necessary to carefully excavate and dispose of granite masonry wall rocks within the required limit of backfill for the floodplain restoration as shown on the Drawings. This Work must be performed with care to avoid damaging the existing rock walls to remain at the site. Materials removed from the walls may be selectively stockpiled for reuse to rebuild or reinforce the wall sections to remain. Payment for this subtask shall be on a unit price basis.

ITEM 8: REBUILDING AND RECONSTRUCTING RETAINING WALLS

This item requires the Contractor to furnish all labor, equipment, and materials necessary to reinforce or rebuild the two retaining walls, formerly part of the foundation for the old mill building, referred to as the Riverside and Upland retaining walls. This shall be done in accordance with Section 32 32 00 Retaining Walls and as shown in the Drawings. This pay item is broken down into the following subtasks:

Item 8A: This item requires the Contractor to furnish all labor, equipment, and materials necessary to reinforce the retaining wall adjacent to the river. This will consist primarily of topping the wall (after having removed rocks to the appropriate elevations) with rocks reused onsite and installing grout between loose rocks. This subtask will be paid on a unit price basis, per linear foot. The wall is approximately 300 feet long and 4 feet high.

Item 8B: This item requires the Contractor to furnish all labor, equipment, and materials necessary to reinforce the retaining wall at the upland end of the restored floodplain. This will consist primarily of filling gaps and reinforcing the existing wall with mortar/grout. This subtask will be paid on a unit price basis per linear foot. The wall is approximately 200 feet long and 10 feet high.

Item 8C: This item requires the Contractor to furnish all labor, equipment, and materials necessary to rebuild a section of the upland retaining wall in accordance with Section 32 32 00 and the Drawings. This will primarily consist of rebuilding the wall to have a step-like appearance for a length of 20 feet, about 3 feet high. This subtask will be paid on a lump sum basis.

ITEM 9: TOPSOIL BACKFILL AND GRADING

This item requires Contractor to furnish all labor, equipment, and materials necessary to transport, place, and appropriately compact approximately 195 CY of clean backfill along the restored floodplain, as indicated on the Drawings and Specifications. Payment for this Pay Item will be on a cost per CY basis.

ITEM 10: SOIL STABILIZATION

This item requires the Contractor to furnish all labor, equipment, and materials necessary to stabilize the soils around the restored floodplain, as detailed in Section 31 32 00 and in the Drawings. This includes the placement of biodegradable (coir) netting around the site as well as sod fasteners to hold it all in place. Payment for this item shall be on a unit price basis in square feet.

ITEM 11: PLANTING AND SEEDING

This item requires the Contractor to furnish all labor, equipment, and materials necessary to plant and seed all restored floodplain areas including, a lower floodplain, upper floodplain, and upland areas as detailed in Section 32 93 00 and in the Drawings. This includes the care and guarantee for all materials for the period of *one full growing season* following construction. The Pay Item is broken into the following subtasks:

Item 11A: This item requires the Contractor to furnish all labor, equipment, and materials necessary to seed all disturbed lands, but most specifically seed all the lands reconstructed along the restored floodplain. This subtask will be paid on a unit price basis, per square foot.

Item 11B: This item requires the Contractor to furnish all labor, equipment, and materials necessary to plant the low floodplain zone, as shown on the Drawings. This specifically includes the smaller shrubs and shrub-tree species. Plants for this shall be livestock or minimum 1-gallon container stock, as specified. Payment for this Work Item will be on a unit price basis, per plant.

Item 11C: This item requires the Contractor to furnish all labor, equipment, and materials necessary to plant the high floodplain zone, as shown on the Drawings. This specifically includes the larger tree species. Plants for this shall be minimum 5-gallon container stock, as specified. Payment for this Work Item will be on a unit price basis, per plant.

ITEM 12: BEDROCK AND CONCRETE EXCAVATION AND DISPOSAL (CONTINGENCY)

Due to the high variability in the shape and frequency of bedrock known to be around the site, plus the unknown depths of concrete foundation, there is a preplanned contingency amount of 80 cubic yards (about 10% the total excavation volume) to help pay for the more expensive excavation and disposal of these two materials.

Available Information

AVAILABLE INFORMATION

**Riparian Floodplain Restoration
Former Woods Woolen Mill
23-25 West Mill Street, Hillsborough, New Hampshire
Engineer’s Project #: 2024-013**

The Former Woods Woolen Mill located at 23-25 West Mill Street in Hillsborough, New Hampshire (the site), has been the subject of several environmental investigations. A list of significant site-related environmental reports is provided below and can be reviewed online at the NHDES OneStop database (<https://www4.des.state.nh.us/DESOnestop/BasicSearch.aspx>) under NHDES Site No. 199909015.

Prior to submitting a Bid, Contractor shall review and understand the available information, and develop appropriate means and methods for executing the Work of these Contract Documents accordingly. Additionally, Contractor shall ensure that the site foreman and laborers fully review and understand the available information prior to implementing remedial actions at the site. Project delays and defective work (i.e., does not adhere to the Drawings and Technical Specifications and is deemed inadequate upon Streamworks inspection) resulting from Contractor, including the site foreman, not fully reviewing and understanding the available information will be at the Contractor’s expense. Signatory indicates that he/she is authorized to endorse the above conditions for Contractor:

Firm: _____

Name (Print): _____

Title: _____

Signature: _____

Date: _____

The information is made available to Contractor for information and factual data only, and is not a warranty of subsurface conditions. Contractor should base their means and methods for executing the Work not only on the available information, but also on local experience and knowledge. Contractor is required to evaluate site conditions that may affect the performance of the Work.

The list below is not intended to be comprehensive; refer to above for additional site-related documentation.

“Woods Woolen Mill Floodplain Restoration, 100% Design Plans, Former Woods Woolen Mill Site on the Contoocook River in Hillsborough, NH”, prepared by Streamworks, PLLC. and dated November 6, 2025 (attached).

“Technical Specifications Former Woods Woolen Mill Site, 23-25 West Mill Street, Hillsborough, NH, NHDES Site No: 19990915”, prepared by Sanborn, Head & Associates, Inc. and Streamworks PLLC, dated November 2025 (attached).

CONTRACTING

Notice of Award

NOTICE OF AWARD

**Riparian Floodplain Restoration
Former Woods Woolen Mill
23-25 West Mill Street, Hillsborough, New Hampshire
Engineer's Project #: 2024-013**

Dated _____ 2025

TO: _____
(BIDDER)

ADDRESS: _____

ENGINEER'S PROJECT NO: 2024-013

PROJECT: Riparian Floodplain Restoration: Former Woods Woolen Mill, Hillsborough, NH

CONTRACT FOR: _____

(Insert name of contract as it appears in the Bid Documents)

You are notified that your Bid dated _____ for the above Contract has been considered. You are the apparent successful bidder and have been awarded a contract for:

(Indicate total Work, alternates or sections of Work awarded)

The Contract Price of your contract is _____

An electronic copy of each of the proposed Contract Documents accompany this Notice of Award.

You must comply with the following conditions precedent within seven (7) days of receiving this Notice of Award.

1. You must deliver to Owner all of the fully executed counterparts of the Agreement including all the Contract Documents. This includes the sets of Drawings. Each of the Contract Documents must bear your signature on (the cover) page. Fully executed Contract Documents are to be provided electronically to the Owner and Engineer.
2. You must deliver with the executed Agreement the Contract Security (Bonds) as specified in the Instruction to Bidders and General or Supplementary Conditions.
3. Contractor must deliver to Owner and Engineer the attached certification signed by a company officer indicating that Contractor has read and understands the documents specified under Available Information.

Failure to comply with these conditions within the time specified will entitle Owner to consider your bid abandoned and to annul this Notice of Award.

(Owner)

By

(AUTHORIZED SIGNATURE)

(TITLE)

ACCEPTANCE OF NOTICE

Receipt of the above NOTICE OF AWARD is hereby acknowledged

By _____

The _____ day of _____, 20 _____

By _____

Title _____

Copy to Engineer

(Use Certified Mail, Return Receipt Requested)

Construction Agreement

CONSTRUCTION AGREEMENT

**Riparian Floodplain Restoration
Former Woods Woolen Mill
23-25 West Mill Street, Hillsborough, New Hampshire
Engineer's Project #: 2024-013**

THIS AGREEMENT made this ____ day of _____ in the year 2026 by and between Town of Hillsborough, NH (hereinafter called "Town" or "Owner") and _____, doing business as an _____ (individual, partnership, or corporation) (hereinafter called "Contractor").

Town and Contractor, in consideration of the mutual covenants hereinafter set forth, agree as follows:

ARTICLE 1. WORK

The Owner has retained Streamworks PLLC. (herein called "Engineer" or "Streamworks") to act as Owner's representative, assume all duties and responsibilities of Engineer, and have the rights and authority assigned to Engineer in the Contract.

Contractor shall commence and complete all Work as specified or indicated in Streamworks' Contract Documents as the Base Bid. Contractor will need to prepare a separate bid for Sanborn Head's Contract which includes brownfields cleanup for a portion of the site. Streamworks' Contract is subject to Streamworks' 100% Design Drawings (Sheet Numbers 1 through 11), and the Technical Specifications, unless otherwise noted as being the responsibility of the "Remediation Engineer". The Work affiliated with Owner's Contract is generally described as Floodplain Restoration at the Former Woods Woolen Mill site located at 23-25 West Mill Street in Hillsborough, New Hampshire, and includes but is not limited to:

- Mobilizing and demobilizing materials, equipment, and personnel required to complete the Work;
- Excavating select areas following brownfields cleanup excavation where rubble, retaining wall, concrete, and bedrock remain on-Site;
- Transporting and disposing of the following waste streams at appropriately permitted, Streamworks-approved, off-site disposal facilities: wood and vegetation from grubbing activities (most importantly, invasive species removal), rubble/wall/concrete/bedrock from within project excavation areas, and accumulated sediment and erosion control;
- Construction of the floodplain within the footprint of the former mill building including soil stabilization measures;
- Planting, seeding, and installing habitat features on the restored floodplain;
- Staging and stockpiling of materials within appropriate lands;

3.2 The Contract Price is reflected in Contractor’s Bid Schedule incorporated as Exhibit A to this Agreement. Estimated quantities provided in the Bid Schedule are not guaranteed, and determinations of actual quantities and classification are to be made during construction.

3.3 The Contract Price may be adjusted only by Change Order as provided by the Contract Documents.

3.4 The term "Contract Documents" means and includes the following:

- 3.4.1 Invitation to Bid
- 3.4.2 Instructions to Bidders
- 3.4.3 Bid Form
- 3.4.4 Bidders Information Form
- 3.4.5 Bid Schedule
- 3.4.6 Available Information
- 3.4.7 Notice of Award
- 3.4.8 Construction Agreement
- 3.4.9 Payment Bond
- 3.4.10 Performance Bond
- 3.4.11 Notice To Proceed
- 3.4.12 Contractor’s Affidavit
- 3.4.13 Contractor’s Release
- 3.4.14 Application For Payment
- 3.4.15 Change Order(s)
- 3.4.16 Certificate of Substantial Completion
- 3.4.17 Certificate of Authority
- 3.4.18 General Conditions
- 3.4.19 Supplemental Conditions
- 3.4.20 Drawings and Specifications Prepared by:

Streamworks PLLC, titled “Woods Woolen Mill Floodplain Restoration 100% Design Plans, Former Woods Woolen Mill Site on the Contoocook River in Hillsborough, New Hampshire” and dated November 6, 2025 (attached).

Sanborn, Head & Associates, Inc., titled “Construction Design Drawings and Technical Specifications, Former Woods Woolen Mill Site, New Hampshire, NHDES Site No: 19990915” and dated December 2025 (attached).

3.4.21 Addenda

No. _____, dated _____, 20__

No. _____, dated _____, 20__

No. _____, dated _____, 20__

No. _____, dated _____, 20__

No. _____, dated _____, 20__

ARTICLE 4. PAYMENT PROCEDURES

Contractor shall submit Applications for Payment in accordance with the General Conditions. Applications for Payment will be reviewed by Streamworks as provided in the General Conditions.

4.1 *Progress Payments.* Owner shall make progress payments on account of the Contract Price on the basis of Contractor's Applications for Payment as recommended by Streamworks, during construction. All such payments will be based upon the approved measured or estimated quantity of each contract item and the corresponding price as reflected in the Bid Schedule (and in the case of Unit Price Work based on the number of units completed) or, in the event there is no item in the Bid Schedule, as provided in the General Requirements.

4.2 *Retainage.* Owner shall pay during the performance of the Work a percentage of approved portions of each Application for Payment, and withhold a percentage of retainage until final completion as described in the General Conditions. Retainage, less an amount adequate to cover: (a) the costs of all defective, rejected or incomplete Work, (b) all damages, losses or expenses incurred by Owner on account of defective, rejected or incomplete Work or Contractor's performance of the Work, and (c) all claims or demands made or liens filed by any person or entity against Owner or Engineer, the Work or the Project site on account of the Work or failure to pay Subcontractors, laborers or Suppliers, shall be paid upon certification of Contractor's completion of the Work as provided by the Contract Documents. The amount of retainage shall in no way limit Contractor's liability under this Agreement.

ARTICLE 5. CONTRACTOR'S REPRESENTATIONS

To induce Owner to enter this Agreement, Contractor makes the following representations:

5.1 Contractor has examined and carefully studied the Contract Documents (including the Addenda) and the other related data identified in the Bid Documents.

5.2 Contractor has become familiar with and is satisfied as to the general, local and site conditions that may affect cost, progress, performance or furnishing of the Work.

- 5.3 Contractor is familiar with and is satisfied as to all Federal, State and local laws and regulations that may affect cost, progress, performance and furnishing of the Work.
- 5.4 Contractor has studied carefully all reports of explorations and tests of subsurface and building conditions which are identified in the Contract Documents or given to Contractor and has reviewed and checked all information and data shown or indicated on the Contract Documents with respect to existing underground facilities at or contiguous to the site and assumes responsibility for the accurate location of said underground facilities. No additional examinations, investigations, explorations, tests, reports, studies, or similar information or data will be required by Contractor in order to perform and furnish the Work at the Contract Price, within the Contract Time and in accordance with the other terms and conditions of the Contract Documents.
- 5.5 Contractor is aware of the general nature of work to be performed by Streamworks and others at the site that relates to the Work as indicated in the Contract Documents and agrees that the areas for parking and storage and lay down of materials, and access to the site are acceptable to Contractor, and that Streamworks will not be required to alter or interrupt any operations going on at the project site.
- 5.6 Contractor has correlated the information known to Contractor, information and observations obtained from visits to the site, reports and drawings identified in the Contract Documents and all additional examinations, investigations, explorations, tests, studies and data with the Contract Documents.
- 5.7 Contractor has given Streamworks written notice of all conflicts, errors, ambiguities or discrepancies that Contractor has discovered in the Contract Documents and the written resolution thereof by Streamworks is acceptable to Contractor, and the Contract Documents are generally sufficient to indicate and convey understanding of all terms and conditions for performance and furnishing of the Work.
- 5.8 Contractor is experienced and qualified to perform the services described herein, and is properly staffed, organized and financed to perform such services. Contractor shall act as an independent Contractor and not as an agent of Streamworks nor the Town in performing its services, maintaining control over its employees and managing all subcontractors and suppliers.

This Agreement shall be binding upon all parties hereto and their respective heirs, executors, administrators, successors, and assigns.

IN WITNESS WHEREOF, the parties hereto have executed, or caused to be executed by their duly authorized officials, this Agreement.

OWNER:

Town of Hillsborough, NH

By: _____
[CORPORATE SEAL]

Attest _____

CONTRACTOR:

By: _____
[CORPORATE SEAL]

Attest _____

OWNER:

Address for giving notices:

Attn: Laura Buono, Town Administrator,
Town of Hillsborough, NH

P.O. Box 7

27 School Street

Hillsborough, NH 03244

CONTRACTOR:

Address for giving notices:

Agent for Service of Process: _____

(If Contractor is a corporation, attach evidence of authority to sign.)

ENGINEER:

Address for giving notices:

Joel Ballestero

44 Evans Road

Madbury, NH 03823

Payment Bond

PAYMENT BOND

**Riparian Floodplain Restoration
Former Woods Woolen Mill
23-25 West Mill Street, Hillsborough, New Hampshire
Engineer's Project #: 2024-013**

KNOW ALL MEN BY THESE PRESENTS: that

(Name of Contractor)

(Address of Contractor)

a _____, hereinafter called Principal,
(Corporation, Partnership or Individual)

and _____
(Name of Surety)

(Address of Surety)

hereinafter called Surety, are held and firmly bound unto

Town of Hillsborough, NH

(Name of Owner)

P.O Box 7, 27 School Street, Hillsborough, NH 03823

(Address of Owner)

hereinafter called **Owner** and unto all persons, firms, and corporations who or which may furnish labor, or who furnish materials to perform as described under the contract and to their successors and assigns, in the total aggregate penal sum of _____ Dollars, (\$ _____) in lawful money of the United States, for the payment of which sum well and truly to be made, we bind ourselves, our heirs, executors, administrators, successors, and assigns, jointly and severally, firmly by these presents.

THE CONDITION OF THIS OBLIGATION is such that whereas, the Principal entered into a certain contract with **Owner**, dated the _____ day of _____ 20____, a copy of which is hereto attached and made a part hereof for the construction of:
Riparian Floodplain Restoration: Former Woods Woolen Mill, Hillsborough, New Hampshire

NOW, THEREFORE, if the Principal shall promptly make payment to all persons, firms, and corporations furnishing materials for or performing labor in the prosecution of the Work provided for in such Contract, and any authorized extension or modification thereof, including all amounts due for materials, lubricants, oil, gasoline, coal and coke, repairs on machinery, equipment and tools, consumed or used in connection with the construction of such Work, and for all labor cost incurred in such Work including that be a subcontractor, and to any mechanic or materialman lienholder whether it acquires its lien by operation of State or Federal Law; then this obligation shall be void; otherwise to remain in full force and effect.

PROVIDED, that beneficiaries or claimants hereunder shall be limited to the subcontractors, and persons, firms, and corporations having a direct contract with the Principal or its SUBCONTRACTORS.

PROVIDED FURTHER, that the said Surety for value received hereby stipulates and agrees that no change, extension of time, alteration or addition to the terms of the contract or to the Work to be performed thereunder or the Specifications accompanying the same shall in any way affect its obligation on this Bond, and it does hereby waive notice of any such change, extension of time, alteration or addition to the terms of the contract or to the Work or to the Specifications.

PROVIDED, FURTHER that no suit or action shall be commenced hereunder by any claimant: (a) Unless claimant, other than one having a direct contract with the Principal shall have given written notice to any two of the following: The Principal, Owner, or the Surety above named within ninety (90) days after such claimant did or performed the last of the work or labor, or furnished the last of the materials for which said claim is made, stating with substantial accuracy the amount claimed and the name of the party to whom the materials were furnished, or for whom the work or labor was done or performed. Such notice shall be served by mailing the same by registered mail or certified mail, postage prepaid, in an envelope addressed to the Principal, Owner, or Surety, at any place where an office is regularly maintained for the transaction business, or served in any manner in which legal process may be served in the state in which the aforesaid project is located, save that such service need not be made by a public officer. (b) After the expiration of one (1) year following the date on which Principal ceased work on said Contract, it being understood, however, that if any limitation embodied in the Bond is prohibited by any law controlling the construction hereof, such limitation shall be deemed to be amended so as to be equal to the minimum period of limitation permitted by such law.

PROVIDED, FURTHER, that it is expressly agreed that this Bond shall be deemed amended automatically and immediately, without formal and separate amendments hereto, upon amendment to the Contract not increasing the contract price more than 25 percent, so as to bind the Principal and the Surety to the full and faithful performance of the Contract as so amended. The term "Amendment", wherever used in this Bond and whether referring to this Bond, the contract or the loan Documents shall include any alteration, addition, extension or modification of any character whatsoever.

PROVIDED FURTHER, that no final settlement between Owner and Contractor shall abridge the right of any beneficiary hereunder, whose claim may be unsatisfied.

IN WITNESS WHEREOF, this instrument is executed in _____ counterparts, each one of
(number)
which shall be deemed an original, this _____ day of _____, 20 ____ .

ATTEST:

By: _____
(Principal) Secretary

(SEAL)

BY

Principal

(Address)

By: _____
Witness as to Principal

(Address)

(Surety)

ATTEST:

BY

By _____
Witness as to Surety

Attorney - in - Fact

(Address)

(Address)

NOTE: Date of **Bond** must not be prior to date of Contract.
If **Contractor** is partnership, all partners should execute Bond.

IMPORTANT: Surety companies executing **Bonds** must appear on the Treasury Department's most current list (Circular 570 as amended) and be authorized to transact business in the State of New Hampshire.

Performance Bond

PERFORMANCE BOND

**Riparian Floodplain Restoration
Former Woods Woolen Mill
23-25 West Mill Street, Hillsborough, New Hampshire
Engineer's Project #: 2024-013**

KNOW ALL MEN BY THESE PRESENTS: that

(Name of Contractor)

(Address of Contractor)

a _____, hereinafter called Principal,

(Corporation, Partnership or Individual)

and

(Name of Surety)

(Address of Surety)

hereinafter called Surety, are held and firmly bound unto

(Name of Owner)

(Address of Owner)

hereinafter called Owner, in the total aggregate penal sum of _____

Dollars, \$ (_____)

in lawful money of the United States, for the payment of which sum well and truly to be made, we bind ourselves, our heirs, executors, administrators successors, and assigns, jointly and severally, firmly by these presents.

THE CONDITION OF THIS OBLIGATION is such that whereas, the Principal entered into a

certain contract with Owner, dated the _____ day of _____ 20 ____, a

copy of which is hereto attached and made a part hereof for the:

_____ Riparian Floodplain Restoration: _____

_____ Former Woods Woolen Mill, Hillsborough, New Hampshire _____

NOW, THEREFORE, if the Principal shall well, truly and faithfully perform its duties, all the undertakings, covenants, terms, conditions, and agreements of said Contract during the original term thereof, and any extension thereof which may be granted by Owner, with or without notice to the Surety and during the one year guaranty period, and if the Principal shall satisfy all claims and demands incurred under such Contract, and shall fully indemnify and save harmless the Owner from all costs and damages which it may suffer by reason of failure to do so, and shall reimburse and repay the Owner all outlay and expense which Owner may incur in making good any default, then this obligation shall be void: otherwise to remain in full force and effect.

PROVIDED, FURTHER, that the said Surety, for value received hereby stipulates and agrees that no change, extension of time, alteration or addition to the terms of the Contract or to Work to be performed thereunder or the Specifications accompanying same shall in any way affect its obligation on this Bond, and it does hereby waive notice of any such change, extension of time alteration or addition to the terms of the Contract or to the Work or to the Specifications.

PROVIDED, FURTHER, that it is expressly agreed that this Bond shall be deemed amended automatically and immediately, without formal and separate amendments hereto, upon amendment to the Contract not increasing the Contract Price more than 25 percent, so as to bind the Principal and the Surety to the full and faithful performance of the Contract as so amended. The term "Amendment", wherever used in this Bond and whether referring to this Bond, the Contract or the loan Documents shall include any alteration, addition, extension or modification of any character whatsoever.

PROVIDED, FURTHER, that no final settlement between Engineer and Contractor shall abridge the right of any beneficiary hereunder, whose claim may be unsatisfied.

IN WITNESS WHEREOF, this instrument is executed in _____ counterparts, each one of which shall be deemed an original, this _____ day of _____, 20 ____.

ATTEST:

By: _____
(Principal) Secretary

(SEAL)

BY

Principal

(Address)

By: _____
Witness as to Principal

(Address)

(Surety)

ATTEST:

BY

By _____
Witness as to Surety

(Address)

Attorney - in - Fact

(Address)

NOTE: Date of Bond must not be prior to date of Contract.

If Contractor is Partnership, all partners should execute Bond

IMPORTANT: Surety companies executing Bonds must appear on the Treasury Department's most current list (Circular 570 as amended) and be authorized to transact business in the State of New Hampshire.

Notice to Proceed

NOTICE TO PROCEED

**Riparian Floodplain Restoration
Former Woods Woolen Mill
23-25 West Mill Street, Hillsborough, New Hampshire
Engineer's Project #: 2024-013**

Dated _____, 20____

TO: _____
(Insert Name of Contractor as it appears in the Bid Documents)

ADDRESS: _____

ENGINEER'S PROJECT NO. 2024-013

PROJECT: Riparian Floodplain Restoration: Former Woods Woolen Mill, Hillsborough, NH

OWNER'S CONTRACT NO. _____

CONTRACT FOR: _____

You are notified that the Contract Time under the above contract will commence to run on _____, 20____. By that date, you are to start performing your obligations under the Contract Documents. In accordance with Article 2 of the Agreement, the dates of Substantial Completion and Final Completion are _____, 20____ and _____, 20____, respectively.

Before you may start any Work at the site, paragraph 22 of the General Conditions provides that you must deliver to Owner (with copies to Engineer) certificates of insurance which is required to be purchased and maintained in accordance with the Contract Documents.

Also before you may start any Work at the site, you must:

(add other requirements)

Copy to Engineer

(Use Certified Mail, Return Receipt Requested)

By

(Engineer)

(Authorized Representative)

(Title)

ACCEPTANCE OF NOTICE

Receipt of the above Notice to Proceed is hereby acknowledged by:

(Contractor)

this the _____, 20 ____

Employer Identification

Number: _____

By: _____

(Title)

Contractor's Affidavit

CONTRACTOR'S AFFIDAVIT

**Riparian Floodplain Restoration
Former Woods Woolen Mill
23-25 West Mill Street, Hillsborough, New Hampshire
Engineer's Project #: 2024-013**

STATE OF: _____

COUNTY OF: _____

Before me, the undersigned, a _____
(Notary Public, Justice of Peace, Alderman)

in and for said County and State personally appeared, _____
(Individual, Partner or duly

_____ who being duly sworn according to law
authorized representative of corporate contractor)

deposes and says that the cost of all the Work, and outstanding claims and indebtedness of whatever
nature arising out of the performance of the contract between _____
(Owner)

and _____ of _____
(Contractor)

dated _____ for the construction of the _____

and necessary appurtenant installations have been paid in full.

(Individual, Partner, or duly authorized representative of corporate contractor)

(Title)

Sworn to and subscribed before me

this _____ day of _____, 20 ____

Notary Public

Contractor's Release

CONTRACTOR'S RELEASE

**Riparian Floodplain Restoration
Former Woods Woolen Mill
23-25 West Mill Street, Hillsborough, New Hampshire
Engineer's Project #: 2024-013**

KNOW ALL MEN BY THESE PRESENTS that _____

(Contractor)

of _____, County of _____
and State of _____ do _____ hereby acknowledge that

(Contractor)

has _____ this day had, and received of and from _____

(Owner)

the sum of One Dollar and other valuable considerations in full and complete satisfaction and
payment of all sums of money owed, payable and belonging to

(Contractor)

by any means whatsoever, for on account of a Contract Agreement between

(Owner)

and _____
(Contractor)

dated _____ for Riparian Floodplain Restoration
(Project)

NOW, THEREFORE, the said _____
(Contractor)

(for myself, my heirs, executors and administrators) (for itself, its successors and assigns)

do/does, by these presents remise, release, quit-claim and forever discharge _____
(Owner)

_____, of and from all claims and demands, arising from or in
connection with the said contract dated _____, and of and from all, and all manner of
action and actions, cause and _____
(Owner)

its successors and assigns, which (I, my heirs, executors, or administrators) (it, its successors and assigns) ever had, now have or which (I, my heirs, executors, or administrators) (it, its successors and assigns) hereafter can, shall or may have, for, upon or by reason of any matter, cause, or thing whatsoever; from the beginning of recorded time to the date of these presents.

IN WITNESS WHEREOF,

(Contractor)

has caused these presents to be duly executed this _____ day of _____, 20 _____

Signed, Sealed and Delivered in the presence of:

(Individual - Contractor) (seal)

(Partnership - Contractor) (seal)

(seal) By _____
(Partner)

Attested:

(Corporation)

(Secretary) By _____
(President or Vice President)

(Corp. Seal)

Application for Payment

Contractor's Application for Payment

Owner: <u>Town of Hillsborough, NH</u>	Owner's Project No.: _____
Engineer: <u>Streamworks, PLLC</u>	Engineer's Project No.: <u>2024-013</u>
Contractor: _____	Contractor's Project No.: _____
Project: <u>Former Woods Woolen Mill</u>	
Contract: <u>Riparian Floodplain Restoration</u>	
Application No.: _____	Application Date: _____
Application Period: From _____ to _____	

1. Original Contract Price	\$	-
2. Net change by Change Orders	\$	-
3. Current Contract Price (Line 1 + Line 2)	\$	-
4. Total Work completed and materials stored to date (Sum of Column G Lump Sum Total and Column J Unit Price Total)	\$	-
5. Retainage		
a. _____ X \$ - Work Completed =	\$	-
b. _____ X \$ - Stored Materials =	\$	-
c. Total Retainage (Line 5.a + Line 5.b)	\$	-
6. Amount eligible to date (Line 4 - Line 5.c)	\$	-
7. Less previous payments (Line 6 from prior application)		
8. Amount due this application	\$	-
9. Balance to finish, including retainage (Line 3 - Line 4 + Line 5.c)	\$	-

Contractor's Certification

The undersigned Contractor certifies, to the best of its knowledge, the following:

(1) All previous progress payments received from Owner on account of Work done under the Contract have been applied on account to discharge Contractor's legitimate obligations incurred in connection with the Work covered by prior Applications for Payment;

(2) Title to all Work, materials and equipment incorporated in said Work, or otherwise listed in or covered by this Application for Payment, will pass to Owner at time of payment free and clear of all liens, security interests, and encumbrances (except such as are covered by a bond acceptable to Owner indemnifying Owner against any such liens, security interest, or encumbrances);

(3) All the Work covered by this Application for Payment is in accordance with the Contract Documents and is not defective; and,

(4) An itemized back-up table (by bid item) is attached to each invoice.

Contractor: _____

Signature: _____ **Date:** _____

Recommended by Engineer	Approved by Owner
By: _____	By: _____
Title: _____	Title: _____
Date: _____	Date: _____
Approved by Funding Agency	
By: _____	By: _____
Title: _____	Title: _____
Date: _____	Date: _____

Progress Estimate - Lump Sum Work

Contractor's Application for Payment

Owner:	Town of Hillsborough, NH	Owner's Project No.:	
Engineer:	Streamworks, PLLC	Engineer's Project No.:	2024-013
Contractor:		Contractor's Project No.:	
Project:	Former Woods Woolen Mill		
Contract:	Riparian Floodplain Restoration		

Application No.: _____ Application Period: From _____ to _____ Application Date: _____

A	B	C	D	E	F	G	H	I
Item No.	Description	Scheduled Value (\$)	Work Completed		Materials Currently Stored (not in D or E) (\$)	Work Completed and Materials Stored to Date (D + E + F) (\$)	% of Scheduled Value (G / C) (%)	Balance to Finish (C - G) (\$)
			(D + E) From Previous Application (\$)	This Period (\$)				
Change Orders								
						-		-
						-		-
						-		-
						-		-
						-		-
						-		-
						-		-
						-		-
						-		-
						-		-
						-		-
						-		-
						-		-
						-		-
						-		-
						-		-
						-		-
						-		-
						-		-
						-		-
						-		-
	Change Order Totals	\$ -	\$ -	\$ -	\$ -	\$ -		\$ -
Original Contract and Change Orders								
	Project Totals	\$ -	\$ -	\$ -	\$ -	\$ -		\$ -

Progress Estimate - Unit Price Work

Contractor's Application for Payment

Owner: Town of Hillsborough, NH
 Engineer: Streamworks, PLLC
 Contractor: _____
 Project: Former Woods Woolen Mill
 Contract: Riparian Floodplain Restoration

Owner's Project No.: _____
 Engineer's Project No.: 2024-013
 Contractor's Project No.: _____

Application No.: _____ Application Period: From _____ to _____ Application Date: _____

A	B	C	D	E	F	G	H	I	J	K	L
Bid Item No.	Description	Contract Information				Work Completed		Materials Currently Stored (not in G) (\$)	Work Completed and Materials Stored to Date (H + I) (\$)	% of Value of Item (J / F) (%)	Balance to Finish (F - J) (\$)
		Item Quantity	Units	Unit Price (\$)	Value of Bid Item (C X E) (\$)	Estimated Quantity Incorporated in the Work	Value of Work Completed to Date (E X G) (\$)				
Original Contract											
					-		-		-		-
					-		-		-		-
					-		-		-		-
					-		-		-		-
					-		-		-		-
					-		-		-		-
					-		-		-		-
					-		-		-		-
					-		-		-		-
					-		-		-		-
					-		-		-		-
					-		-		-		-
					-		-		-		-
					-		-		-		-
					-		-		-		-
					-		-		-		-
					-		-		-		-
					-		-		-		-
					-		-		-		-
Original Contract Totals					\$ -		\$ -	\$ -	\$ -		\$ -

Progress Estimate - Unit Price Work

Contractor's Application for Payment

Owner: Town of Hillsborough, NH
 Engineer: Streamworks, PLLC
 Contractor: _____
 Project: Former Woods Woolen Mill
 Contract: Riparian Floodplain Restoration

Owner's Project No.: _____
 Engineer's Project No.: 2024-013
 Contractor's Project No.: _____

Application No.: _____ Application Period: From _____ to _____ Application Date: _____

A	B	C	D	E	F	G	H	I	J	K	L
Bid Item No.	Description	Contract Information				Work Completed		Materials Currently Stored (not in G) (\$)	Work Completed and Materials Stored to Date (H + I) (\$)	% of Value of Item (I / F) (%)	Balance to Finish (F - J) (\$)
		Item Quantity	Units	Unit Price (\$)	Value of Bid Item (C X E) (\$)	Estimated Quantity Incorporated in the Work	Value of Work Completed to Date (E X G) (\$)				
Change Orders											
					-		-		-		-
					-		-		-		-
					-		-		-		-
					-		-		-		-
					-		-		-		-
					-		-		-		-
					-		-		-		-
					-		-		-		-
					-		-		-		-
					-		-		-		-
					-		-		-		-
					-		-		-		-
					-		-		-		-
					-		-		-		-
					-		-		-		-
					-		-		-		-
					-		-		-		-
					-		-		-		-
					-		-		-		-
					-		-		-		-
Change Order Totals					\$ -		\$ -	\$ -	\$ -		\$ -
Original Contract and Change Orders											
Project Totals					\$ -		\$ -	\$ -	\$ -		\$ -

Change Orders

CHANGE ORDER

**Riparian Floodplain Restoration
Former Woods Woolen Mill
23-25 West Mill Street, Hillsborough, New Hampshire
Engineer's Project #: 2024-013**

No. _____

PROJECT: Riparian Floodplain Restoration DATE OF ISSUANCE: _____
 Engineer: Joel Ballestero, Streamworks PLLC
 44 Evans Road, Madbury, NH 03823
 (Address)

CONTRACTOR: _____ ENGINEER's Project 2024-013
 CONTRACT FOR: _____

You are directed to make the following changes in the Contract Documents.

Description:

Purpose of Change Order:

Justification:

Attachments: (List documents supporting change)

CHANGE IN CONTRACT PRICE	CHANGE IN CONTRACT TIME
Original Contract Price \$ _____	Original Contract Time _____ (days or date)
Previous Change Orders \$ _____	Net change from previous Change Orders _____ (days)
Contract Price prior to this Change Order \$ _____	Contract Time prior to this Change Order _____ (days or date)
Net Increase (Decrease) of this Change Order \$ _____	Net Increase (decrease) this Change Order _____ (days)
Contract Price with all approved Change Orders \$ _____	Contract Time with all Change Orders _____ (days or date)

This document will become a supplement to the Contract and all provisions will apply hereto. The attached Contractor's Revised Project Schedule reflects increases or decreases in Contract Time as authorized by this Change Order.

Stipulated price and time adjustment includes all costs and time associated with the above-described change. Contractor waives all rights for additional time extension for said change. Contractor and

Engineer agree that the price(s) and time adjustment(s) stated above are equitable and acceptable to both parties.

RECOMMENDED BY:

Engineer

Date

APPROVED BY:

Engineer

Date

Contractor

Date

Certificate of Substantial Completion

A tentative list of items to be completed or corrected is attached hereto. This list may not be all-inclusive, and the failure to include an item in it does not alter the responsibility of Contractor to complete all the Work in accordance with Contract Documents. The items in the tentative list shall be completed or corrected by Contractor within _____ calendar days of the above date of Substantial Completion.

The responsibilities between Engineer and Contractor for security, operation, safety, maintenance, heat, utilities, insurance and warranties shall be as follows:

RESPONSIBILITIES:

ENGINEER:

CONTRACTOR:

The following documents are attached to and made a part of this Certificate:

This certificate does not constitute an acceptance of Work not in accordance with the Contract Documents nor is it a release of Contractor's obligation to complete the Work in accordance with the Contract Documents.

Executed by Engineer on _____, 20 _____

Streamworks, PLLC.

(Engineer)

By: _____

Contractor accepts this Certificate of Substantial Completion on _____, 20 _____

(Contractor)

By: _____

Owner accepts this Certificate of Substantial Completion on _____, 20 _____

(Owner)

By: _____

Certificate of Authority

CERTIFICATE OF AUTHORITY

**Riparian Floodplain Restoration
Former Woods Woolen Mill
23-25 West Mill Street, Hillsborough, New Hampshire
Engineer's Project #: 2024-013**

At a meeting of _____ Board of Directors held on _____ at
(Company Name)
which a quorum was present, it was voted that the following individuals of this company, be
and are hereby authorized to execute contracts and bonds in the name of and on behalf of said
company, and to affix its corporate seal thereto (if applicable), and such execution of any
contract or obligation in this company's name or on its behalf by such individual, under seal of
the company (if applicable), shall be valid and binding upon this company.

Name	Title
_____	_____
_____	_____

I hereby certify that I am the clerk of the above-named company, and that the information above is correct and that the above vote has not been amended or rescinded and remains in full force and effect as of this date.

(Clerk signature) (Date)

A true copy, _____
(Attested by Notary Public)

My commission expires on _____
(Date)

General Conditions

GENERAL CONDITIONS

**Brownfields Cleanup
Former Woods Woolen Mill
23-25 West Mill Street, Hillsborough, New Hampshire
NHDES Site #: 199909015**

Index

1. Contract and Contract Documents
2. Definitions
3. Additional Instructions and Detail Drawings
4. Materials, Services, and Facilities
5. Contractor's Title to Materials
6. Inspection and Testing
7. "Or Equal" Clause, Substitutions and Contractor Options
8. Surveys and Construction Layout
9. Contractor's Obligations
10. Weather Conditions
11. Protection of Work and Property
12. Inspection
13. Reports, Records, and Data
14. Extra Work and Change Orders
15. Time for Completion and Liquidated Damages
16. Defective Work
17. Claims for Differing Site Conditions
18. Claims for Extra Cost
19. Right of Engineer to Terminate Contract
20. Payments to Contractor
21. Acceptance and Final Payment
22. Insurance
23. Bonds
24. Subcontracting
25. Authority of Owner's Representative
26. Use of Premises, Removal of Debris, Sanitary Conditions
27. Estimated Quantities
28. General Guaranty
29. Errors and Inconsistencies in Contract Documents
30. Notice and Service Thereof
31. Required Provisions Deemed Inserted
32. Health and Safety Responsibilities
33. Compliance by Contractor with Laws and Regulations: Equal Employment Opportunity
34. Pre-Construction Meeting
35. Work Performed at Night, and on Weekends and Holidays
36. Laws, Permits, Rules, and Ordinances
37. Indemnification

GENERAL CONDITIONS

1.0 Contract and Contract Documents

- 1.1 The Invitation to Bid, Information for Bidders, Bids, Payment and Performance Bonds, General Conditions, Agreements, Change Orders, Notice of Award, Notice to Proceed, Sanborn Head's Construction Design Drawings, Sanborn Head's Technical Specifications and Addenda, hereinafter enumerated in the Agreement, shall form part of this Contract and the provisions thereof shall be as binding upon the parties hereto as if they were herein fully set forth. The table of contents, titles, headings, running headlines and marginal notes contained herein and in said documents are solely to facilitate reference to various provisions of the Contract Documents and in no way affect, limit or cast light on the interpretation of the provisions to which they refer.

2.0 Definitions

- 2.1 "Addenda" means written or graphic instruments issued prior to the execution of the Agreement which modify or interpret the Contract Documents, drawings and specifications, by additions, deletions, clarifications or corrections.
- 2.2 "Bid" means the offer or proposal of the Bidder submitted on the prescribed form setting forth the prices for the Work to be performed.
- 2.3 "Bidder" means any person, firm or corporation submitting a Bid for the Work.
- 2.4 "Bonds" means Performance and Payment Bonds and other instruments of security, furnished by Contractor and their surety in accordance with the Contract Documents.
- 2.5 "Change Order" means a written order to Contractor authorizing an addition or "Extra Work", deletion or revision in the Work within the general scope of the Contract Documents or authorizing an adjustment in the Contract Price or Contract Time.
- 2.6 "Contract Documents" means the Contract, including any advertisement for Bids, Information for Bidders, Bid, Agreement, Payment Bond, Performance Bond, Notice of Award, Notice to Proceed, Change Orders, Sanborn Head's Construction Design Drawings, Sanborn Head's Technical Specifications and Addenda.
- 2.7 "Contract Price" means the total monies payable to Contractor under the terms and conditions of the Contract Documents.
- 2.8 "Contract Time" means the number of calendar days stated in the Contract Documents for the completion of the Work.

- 2.9 “Contractor” means the person, firm, or corporation with whom Sanborn Head has executed the Agreement.
- 2.10 “Days” means business days unless specifically stated otherwise.
- 2.11 “Drawings” mean the part of the Contract Documents which show the characteristics, scope, dimensions, and details of the Work to be performed and which have been prepared by Sanborn Head and approved by Owner.
- 2.12 “Engineer” means Sanborn, Head & Associates, Inc., who is also referred to as Sanborn Head throughout the Contract Documents.
- 2.13 “Field Order” means a written order effecting a change in the Work not relating to an adjustment in the Contract Price or an extension of the Contract Time and issued by Owner’s Representative to Contractor during construction.
- 2.14 “Final Completion” means that point at which all Work has been completed and all defective Work has been corrected.
- 2.15 “NHDES” means the New Hampshire Department of Environmental Services who is providing funding and regulatory guidance for the remediation project.
- 2.16 “Notice of Award” means the written notice of the acceptance of the Bid from Sanborn Head to the successful Bidder.
- 2.17 “Notice to Proceed” means the written communication issued by Sanborn Head to Contractor authorizing them to proceed with the Work and establishing the date of commencement of the Work.
- 2.18 “Owner” means the Town of Hillsborough (property Owner).
- 2.19 “Project” means the undertaking to be performed as provided in the Contract Documents.
- 2.20 “Owner’s Representative” means the authorized representative of Owner who is assigned to the Project site or any part thereof and may include Sanborn Head, or others as designated by Owner.
- 2.21 “Shop Drawings” means all drawings, diagrams, illustrations, brochures, schedules, and other data which are prepared by Contractor, a Subcontractor, manufacturer, supplier or distributor, which illustrates how specific portions of the Work shall be fabricated or installed.
- 2.22 “Special Conditions” means revisions or additions to these General Conditions, Supplemental Conditions, or specifications applicable to an individual project.

- 2.23 “Specifications” means a part of the Contract Documents consisting of written descriptions of a technical nature of materials, equipment, construction systems, standards, and workmanship and which have been prepared by Sanborn Head and approved by NHDES.
- 2.24 “Subcontractor” means an individual, firm, or corporation having a direct contract with Contractor or with any other Subcontractor for the performance of a part of the Work at the site.
- 2.25 “Substantial Completion” means that date when the Work as described in the Contract Documents has been completed to the extent that Owner may occupy and/or make use of the Work performed for the purposes for which it was intended.
- 2.26 “Supplemental Conditions” means modifications to these General Conditions.
- 2.27 “Supplier” means any person or organization who supplies materials or equipment for the Work, including that fabricated to a special design, but who does not perform labor at the site.
- 2.28 “Work” means all labor necessary, including all materials and equipment incorporated or to be incorporated, to produce the construction required by Sanborn Head’s Contract Documents.
- 2.29 “Written Notice” means any notice to any party of the Agreement relative to any part of this Agreement in writing and considered delivered and the service thereof completed, when emailed and posted by certified or registered mail to the said party at their last given address or delivered in person to said party or their authorized representative on the Work.

3.0 Additional Instructions and Detail Drawings

- 3.1 Contractor may be furnished additional instructions and detail drawings as necessary to carry out the Work included in the Contract Documents. The additional drawings and instructions thus supplied to Contractor will coordinate with the Contract Documents and will be so prepared that they can be reasonably interpreted as part thereof.

4.0 Materials, Services, and Facilities

- 4.1 Except as otherwise specifically stated in the Contract Documents, Contractor shall provide and pay for all materials, labor, tools, equipment, water, light, power, transportation, superintendence, temporary construction of every nature, and all other services and facilities of every nature whatsoever necessary to execute, complete, and deliver the Work within the specified time.

5.0 Contractor's Title to Materials

- 5.1 No material, supplies, or equipment to be installed or furnished under this Contract shall be purchased subject to any chattel mortgage or under a conditional sale, lease purchase or other agreement by which an interest therein or in any part thereof is retained by the seller or supplier. Contractor shall warrant good title to all materials, supplies, and equipment installed or incorporated in the Work and upon completion of all Work, shall deliver the same together with all improvements and appurtenances constructed or placed thereon by them to Sanborn Head and Owner free from any claims, liens, or charges. Neither Contractor nor any person, firm or corporation furnishing any material or labor for any Work covered by this Contract shall have any right to a lien upon any improvement or appurtenance thereon. Nothing contained in this paragraph, however, shall defeat or impair the right of persons furnishing materials or labor to recover under any bond given by Contractor for their protection or any rights under any law permitting such persons to look to funds due Contractor in the hands of Sanborn Head or Owner. The provisions of this paragraph shall be inserted in all subcontracts and material contracts and notice of its provisions shall be given to all persons furnishing materials for the Work when formal contract is entered into for such materials.

6.0 Inspection and Testing

- 6.1 If the Contract Documents, laws, ordinances, rules, regulations or orders of any public authority having jurisdiction require any Work to specifically be inspected, tested or approved by someone other than Contractor, Contractor will give Sanborn Head timely notice of readiness. Contractor will then furnish Sanborn Head with the required certificates of inspection, testing or approval.
- 6.2 Inspections, tests, or approvals by Sanborn Head or others shall not relieve Contractor from obligations to perform the Work in accordance with the requirements of the Contract Documents.

7.0 "Or Equal" Clause, Substitutions and Contractor Options

- 7.1 Whenever a material, article, or piece of equipment is identified on the plans or in the specifications by reference to manufacturer's or vendor's names, trade names, catalogue numbers, etc., it is intended merely to establish a standard of quality and performance. Any material, article, or equipment of other manufacturers and vendors, which will perform satisfactorily the duties imposed by the general design, shall be considered equally acceptable provided the material, article, or equipment so proposed is, in the opinion of Sanborn Head, of equal quality and function. Sanborn Head shall determine equality based on such information, tests, or other supporting data that may be required of Contractor.

- 7.2 Upon acceptance and approval by Sanborn Head of an equal product, it shall remain the responsibility of Contractor to coordinate installation of the item with all other items to be furnished to assure proper fitting together of all items. Similar responsibility applies to items which are left to Contractor's option. Any additional cost of equal items and any additional cost incidental to the coordination and/or fitting together of such items shall be borne by Contractor at no extra cost to Sanborn Head or NHDES.
- 7.3 If a specified or equal item is not available to meet the construction schedule, Contractor may propose a substitute item of less than equal performance and quality. If this substitute is acceptable to Sanborn Head, any difference in purchase cost or costs incidental to the installation of such item will be negotiated between the parties to the contract.
- 7.4 Neither equal nor substitute items shall be installed without written approval of Sanborn Head.
- 7.5 Contractor shall warrant that if substitutes are approved, no major changes in the function or general design of the Project will result.

8.0 Surveys and Construction Layout

- 8.1 Contractor shall be responsible for hiring a New-Hampshire licensed surveyor to layout proposed construction areas in accordance with the Design Drawings including, but not limited to: Excavation Areas, Cap Areas, staging areas, etc.
- 8.2 Protection of stakes. Contractor shall protect and preserve all of the established baseline stakes, benchmarks, or other controls placed by Sanborn Head. Any of these items destroyed or lost through fault of Contractor will be replaced by the Contractor at Contractor's expense.

9.0 Contractor's Obligations

- 9.1 Contractor's obligation is as follows: Contractor shall and in good manner, do and perform all Work and furnish and pay for all supplies and materials, machinery, equipment, facilities and means, except as herein otherwise expressly specified, necessary or proper to perform and complete all the Work required by this Contract, within the time stated in the proposal in accordance with the plans and drawings covered by this Contract, and any and all supplemental plans and drawings, in accordance with the directions of Owner's Representative as given from time to time during the progress of the Work, whether or not they consider the direction in accordance with the terms of the Contract. Contractor shall furnish, erect, maintain, and remove such construction plant and such temporary works as may be required. Contractor shall observe, comply with, and be subject to all terms, conditions,

requirements, and limitations of the Contract Documents, and shall do, carry on and complete the entire Work to the satisfaction of Owner's Representative and Owner.

- 9.2 Contractor shall carry on the Work and adhere to the progress schedule during all disputes, disagreements, or unresolved claims with Sanborn Head, Owner or NHDES. No Work shall be delayed or postponed pending the resolution of any disputes, disagreements, or claims except as Sanborn Head, Owner, NHDES, and Contractor may otherwise agree to in writing.

10.0 Weather Conditions

- 10.1 In the event of temporary suspension of Work, or during inclement weather, or whenever Owner's Representative shall indicate, Contractor and their Subcontractors shall protect their work and materials against damage or injury from the weather. If, in the opinion of Owner's Representative, any Work or material shall have been damaged or injured by reason of failure on the part of Contractor or any of their Subcontractors to so protect their work, such materials shall be removed and replaced at the expense of Contractor.

11.0 Protection of Work and Property

- 11.1 Contractor shall at all times safely guard the Owner's property from injury or loss in connection with this Contract. Contractor shall at all times safely guard and protect their own work, and that of adjacent property, from damage. Contractor shall replace or make good any such damage, loss or injury unless caused directly by errors contained in the Contract, or by Owner, or Owner's Representative. Contractor will notify owners of adjacent utilities when prosecution of the Work may affect them.
- 11.2 Contractor shall take all necessary precautions for the safety of employees on the Project site, and shall comply with all applicable provisions of federal, state and municipal safety laws and building codes to prevent accidents or injury to persons on, about or adjacent to the premises where the Work is being performed. Contractor shall erect and properly maintain at all times, as required by the conditions and progress of the Work, all necessary safeguards for the protection of the workers and the public and shall post danger signs warning against the hazards created by such features of construction as protruding nails, hoists, well holes, elevator hatchways, scaffolding, window openings, stairways, trenches and other excavations, and falling materials.
- 11.3 In case of emergency which threatens loss or injury of property, and/or safety of life, Contractor is allowed to act, without previous instructions from Owner's Representative. Contractor shall notify Owner's Representative immediately thereafter. Any claim for compensation by Contractor due to such extra work shall be promptly submitted in writing to Owner's Representative for approval.

- 11.4 When Contractor has not taken action but has notified Owner's Representative of an emergency threatening injury to persons or damage to the Work or any adjoining property, they shall act as instructed or authorized by Owner's Representative.
- 11.5 The intention is not to relieve Contractor from acting, but to provide for consultations between Owner's Representative and Contractor in an emergency which permits time for such consultations.
- 11.6 The amount of reimbursement claimed by Contractor on account of any emergency action shall be determined in the manner provided in Article 14 (Extra Work and Change Orders) of the General Conditions.

12.0 Inspection

- 12.1 For purposes of inspection and for any other purpose, Owner, Owner's Representative, and agents and employees of Owner or of any funding agency may enter upon the Work and the premises used by Contractor, and Contractor shall provide safe and proper facilities therefore. Owner's Representative shall be furnished with every facility for ascertaining that the Work is performed in accordance with the requirements and intention of this Contract, even to the extent of uncovering or taking down portions of finished Work.
- 12.2 During construction and on its completion, all Work shall conform to the location, lines, levels and grades indicated on the Drawings or established on the site by Owner's Representative and shall be built in accordance with the Drawings and Specifications and the supplementary directions given from time to time by Owner's Representative. In no case shall any Work which exceeds the requirements of the Drawings and Specifications be paid for as Extra Work unless ordered in writing by Owner's Representative.
- 12.3 Unauthorized work and work not conforming to Drawings and Specifications shall be handled as follows:
 - a. Work considered by Owner's Representative to be outside of or different from the Drawings and Specifications and done without instruction by Owner's Representative, or in wrong location, or done without proper lines or levels, may be ordered by Owner's Representative to be uncovered or dismantled.
 - b. Work done in the absence of Owner's Representative or their agent may be ordered by Owner's Representative to be uncovered or dismantled.
 - c. Should the Work thus exposed or examined prove satisfactory, the uncovering or dismantling and the replacement of material and rebuilding of

the Work shall be considered as "Extra Work" to be processed in accordance with Article 14.

- d. Should the Work thus exposed or examined prove to be unsatisfactory the uncovering or dismantling and the replacement of material and rebuilding of the Work shall be at the expense of Contractor.

13.0 Reports, Records and Data

- 13.1 Reports, records and data shall be furnished as follows: Contractor shall submit to Sanborn Head such schedule of quantities and costs, progress schedules, payrolls, reports, estimates, records and other data as are required by the Contract Documents or as Owner or any funding agency may request concerning Work performed or to be performed under this Contract.

14.0 Extra Work and Change Orders

- 14.1 Owner's Representative may at any time by written order and without notice to the Sureties require the performance of such Extra Work or changes in the Work as may be found necessary or desirable. The amount of compensation to be paid to Contractor for any Extra Work so ordered shall be made in accordance with whichever of the following plans Owner's Representative elects and which is approved in consultation with the Owner: (1) a price agreed upon between the parties and stipulated in the order for the Extra Work, or (2) a price based on the unit prices of the Contract.
- 14.2 Owner's Representative may authorize minor changes or alterations in the Work not involving extra cost and not inconsistent with the overall intent of the Contract Documents. These shall be accomplished by a written Field Order. However, if Contractor believes that any minor change or alteration authorized by Owner's Representative entitles them to an increase in the contract price, he may make a claim therefore as provided in Article 18.

15.0 Time for Completion and Liquidated Damages

- 15.1 It is hereby understood and mutually agreed, by and between Contractor and Owner and Sanborn Head, that the date of beginning and the time for completion as specified in the Contract of the Work to be done hereunder are Essential Conditions of this Contract; and it is further mutually understood and agreed that the Work embraced in this Contract shall be commenced on a date to be specified in the "Notice to Proceed."
- 15.2 Contractor agrees that said Work shall be pursued regularly, diligently, and continuously at such rate of progress as will ensure full completion thereof within the time specified. It is expressly understood and agreed, by and between

Contractor and Sanborn Head, that the time for the completion of the Work described herein is a reasonable time, taking into consideration the average climatic range and usual industrial conditions prevailing in this locality.

- 15.3 If Contractor shall neglect, fail or refuse to complete the Work within the time herein specified, or any proper extension thereof granted by Sanborn Head, funding agency, and Owner, then Contractor does hereby agree, as a part consideration for the awarding of this Contract, to pay to Sanborn Head the amount specified in the contract (\$1,500 for each day, in whole or in part, that expires after 60 calendar days from the date of mobilization), not as a penalty but as liquidated damages for such breach of Contract as hereinafter set forth, for each and every calendar day that Contractor shall be in default after the time stipulated in the contract for completing the Work.
- 15.4 The liquidated damages amount is fixed and agreed upon by and between Contractor and Sanborn Head because of the impracticability and extreme difficulty of fixing and ascertaining the actual damages Sanborn Head would in such event sustain. Said amount is agreed to be the amount of damages that Sanborn Head and/or Owner would sustain and said amount shall be deducted by Sanborn Head from current periodical payments.
- 15.5 It is further agreed that "time is of the essence" of each and every portion of this Contract and of the Specifications wherein a definite and certain length of time is fixed for the performance of any act whatsoever; and where under the Contract an additional time is allowed for the completion of any Work, the new time limit fixed by such extension shall "be of the essence". Provided, that Contractor shall not be charged with liquidated damages or any excess cost when Sanborn Head determines that Contractor is without fault and Contractor's reasons for the time extension are acceptable to Sanborn Head; provided, further, that Contractor shall not be charged with liquidated damages or any excess cost when the delay in the completion of the Work is due to:
- a. A preference, priority, or allocation order duly issued by the government;
 - b. An unforeseeable cause beyond the control and without the fault or negligence of Contractor, including, but not restricted to, acts of God, or of the public enemy, acts of Owner, acts of another Contractor in the performance of a Contract with Owner, fires, floods, epidemics, quarantine restrictions, strikes, freight embargoes, and severe weather;
 - c. Any delays of Subcontractors or suppliers occasioned by any of the causes specified in subsections (a) and (b) of this article.

- 15.6 Contractor shall promptly notify Sanborn Head in writing of the causes of the delay. Sanborn Head shall ascertain the facts and extent of the delay and notify Contractor within a reasonable time of their decision in the matter.

16.0 Defective Work

- 16.1 Contractor shall promptly remove from the premises all materials and Work condemned by Owner's Representative as failing to meet Contract requirements, whether incorporated in the Work or not, and Contractor shall promptly replace and re-execute their own Work in accordance with the Contract and without expense to Sanborn Head and funding agency and shall bear the expense of making good all Work of other Contractors which was destroyed or damaged by such removal or replacement.
- 16.2 All removal and replacement Work shall be done at Contractor's expense. If Contractor does not take action to remove such condemned Work and materials within ten (10) days after receipt of written notice, Sanborn Head or Owner may remove them and store the material at the expense of Contractor. If Contractor does not pay the expense of such removal and storage within ten (10) days' time thereafter, Sanborn Head or Owner may, upon ten (10) days written notice, sell such materials at auction or at private sale and shall pay to Contractor any net proceeds thereof, after deducting all the costs and expenses that should have been borne by Contractor, including expenses for moving, handling, and storage.

17.0 Claims for Differing Site Conditions

- 17.1 Contractor shall, upon discovery, and without further disturbance, notify Owner's Representative in writing of:
- a. Subsurface or latent physical conditions at the site differing materially from those indicated in this Contract; or,
 - b. Unknown physical conditions at the site, differing materially from those ordinarily encountered and generally recognized as inherent in the type of work provided for in this Contract.
- 17.2 Owner's Representative shall promptly investigate the conditions. If they find that conditions differ materially and will cause an increase or decrease in Contractor's cost or the time required to perform any part of the Work under this Contract, Owner's Representative, after consultation with Owner, shall make an equitable adjustment and modify the Contract in writing.
- 17.3 No claim of Contractor under this clause shall be allowed unless Contractor has given proper notice as required in Article 17.1 of this clause.

- 17.4 No claim by Contractor for an equitable adjustment shall be allowed if asserted after final payment under this Contract.

18.0 Claims for Extra Cost

- 18.1 No claim for extra work or cost shall be allowed unless the same was done pursuant to a written order by Owner's Representative, approved in consultation with Owner and/or funding agency, and the claim presented for payment with the first estimate after the changed or Extra Work is done.
- 18.2 If Contractor claims that any instructions by Drawings or similar documents issued after the date of the Contract involve extra cost under the Contract, they shall give Owner's Representative written notice after the receipt of such instruction and before proceeding to execute the Work, except in an emergency which threatens life or property, then the procedure shall be as provided for under Article 14, "Extra Work & Change Orders." No claim shall be valid unless so made.

19.0 Right of Sanborn Head to Terminate Contract

- 19.1 In the event that any of the provisions of this contract are violated by Contractor, or by any of their Subcontractors, Sanborn Head may serve written notice upon Contractor and the surety of its intention to terminate the Contract, and unless within 10 days after the serving of such notice upon Contractor, such violation or delay shall cease and satisfactory arrangement for correction be made, the Contract shall, upon the expiration of said ten (10) days cease and terminate. In the event of any such termination, Sanborn Head shall immediately serve notice thereof upon the surety and Contractor and the surety shall have the right to take over and perform the Contract; provided, however, that if the surety does not commence performance thereof within ten (10) days from the date of the mailing to such surety of notice of termination, Sanborn Head may take over the Work and prosecute the same to completion by Contract or by force account for and at the expense of Contractor and Contractor and their surety shall be liable to Sanborn Head for any excess cost occasioned by Sanborn Head, and in such event Sanborn Head may take possession of and utilize in completing the Work, such materials, appliances, and equipment as may be on the site of the Work and necessary therefore.
- 19.2 If Contractor should be adjudged bankrupt, or if make a general assignment for the benefit of their creditors, or if a receiver should be appointed on account of insolvency, or if they should refuse or should fail, except in cases for which extensions of time are provided, to supply enough skilled workers or materials, or if they should fail to make payments to Subcontractors or for material or labor, so as to affect the progress of the Work, or be guilty of a violation of the Contract, then Sanborn Head, when sufficient cause exists to justify such action may, without prejudice to any other right or remedy and after giving Contractor and their surety seven (7) days written notice, terminate the employment of Contractor and take

possession of the premises and of all materials, tools, equipment and other facilities installed on the Work and paid for by Sanborn Head, and finish the Work by whatever method they may deem expedient. In the case of termination of this Contract before completion from any cause whatever, Contractor, if notified to do so by Sanborn Head, shall promptly remove any part or all of their equipment and supplies at the expense of Contractor. If such expense exceeds such unpaid balance, Contractor shall pay the difference to Sanborn Head. The expense incurred by Sanborn Head as herein provided, and the damage incurred through Contractor's default, shall be approved by Owner's Representative.

- 19.3 Where the contract has been terminated by Sanborn Head, said termination shall not affect or terminate any of the rights of Sanborn Head as against Contractor or their surety then existing, or which may thereafter accrue because of such default. Any retention or payment of monies by Sanborn Head due Contractor under the terms of the Contract, shall not release Contractor or their surety from liability for default.
- 19.4 After ten (10) days from delivery of a Written Notice to Contractor, Sanborn Head may, without cause and without prejudice to any other remedy, elect to abandon the Project and terminate the Contract. In such case, Contractor shall be paid for all Work executed and any expense sustained plus reasonable profit.
- 19.5 If the performance of all or any portion of the Work is suspended, delayed, or interrupted as a result of failure of Owner or Owner's Representative to act within the time specified in the Contract Documents, or if no time is specified, within a reasonable time, an adjustment in the Contract Price or an extension of the Contract Time, or both, shall be made by Change Order to compensate Contractor for the costs and delays necessarily caused by the failure of Owner or Owner's Representative.

20.0 Payments to Contractor

- 20.1 Progress Payments: Sanborn Head will make a progress payment to Contractor on the basis of an estimate of the total amount of work done, the time of the estimate and its value as prepared by Contractor and approved by Owner's Representative.
- 20.2 The Progress Payment will be paid by Sanborn Head after Sanborn Head receives funds from NHDES.
- 20.3 Retainage by Sanborn Head: Sanborn Head will retain a portion of the progress payment, each month, in accordance with the following procedures:
- a. Retainage shall be 10% of the monthly payments claimed.

- b. Upon substantial completion (as defined in Article 21), and provided Contractor has satisfied Owner's Representative in quality and timeliness of the work, and provided further that there is no specific cause for withholding the full retainage, half of the amount of retainage withheld will be paid to Contractor. The remaining retainage shall be held during the one-year warranty period and released only after NHDES and Sanborn Head have accepted the project and all Contract requirements and documents have been met and submitted.
- 20.4 In reviewing monthly estimates for payments of the value of Work done, Owner's Representative may accept in the estimate, prior to subtracting the retainage, the delivered cost of certain equipment and nonperishable material which have been delivered to the site or off-site location and which are properly stored and protected from damage. With the estimate, Contractor shall submit to Owner's Representative invoices as evidence that the material has been delivered to the site. Prior to submitting the next monthly estimate, Contractor shall provide Owner's Representative with paid invoices or other evidence that the materials have been paid for. If Contractor fails to submit such evidence, Owner's Representative may then subtract the value of such materials or equipment for which NHDES has previously paid, from the next monthly estimate. The type of equipment and material eligible for payment prior to being incorporated in the Work will be at Owner's Representative's discretion. Material and equipment made specifically for the subject job will be eligible for payment.
- 20.5 All material and Work for which partial payments have been made shall thereupon become the sole property of Owner. This provision shall not be construed as relieving Contractor from the sole responsibility for the care and protection of materials and Work upon which payments have been made or for the restoration of any damaged Work, or as a waiver of the right of Sanborn Head to require compliance with all of the terms of the Contract.
- 20.6 Sanborn Head's right to withhold payments and make application. Contractor agrees that they will save Owner, Sanborn Head, funding agency, and Owner's agents harmless from all claims growing out of the lawful demands of Subcontractors, laborers, workmen, mechanics, material men, and furnishers of machinery and parts, equipment, power, tools and all supplies, including commissary, incurred in the furtherance of the performance of this Contract. Contractor shall, at Sanborn Head's request, furnish satisfactory evidence that all claims of the nature hereinabove designated have been paid, discharged, or waived. If Contractor fails to do so, then Sanborn Head may, upon written notice to Contractor either pay unpaid bills of which Sanborn Head has Written Notice directly, or withhold from Contractor's unpaid compensation a sum of money to pay any and all such lawful claims until satisfactory evidence is furnished that all liabilities have been fully discharged. Payment to Contractor shall then be resumed in accordance with the terms of this Contract but in no event shall the above provisions be construed to

impose any obligations upon Sanborn Head to either Contractor or their surety or any third party. In paying any unpaid bills of Contractor, Owner or Sanborn Head shall be deemed the agent of Contractor, and any payment so made by Owner or Sanborn Head shall be considered as payment made under contract by Sanborn Head to Contractor and Sanborn Head shall not be liable to Contractor for any such payments made in good faith.

- 20.7 If Sanborn Head fails to make payment forty-five (45) days after receipt of funds from Owner, in addition to other remedies available to Contractor, there shall be added to each such payment interest at an annual rate of 5% commencing on the first day after said payment is due and continuing until the payment is received by Contractor.

21.0 Acceptance and Final Payment

21.1 Substantial completion and payment.

- a. Substantial completion shall be that point, as approved by Owner's Representative, at which the Contract has been completed to the extent that Owner may occupy and/or make use of the Work performed for the purposes for which it was intended. Upon substantial completion, there may be minor items, such as seeding, landscaping, etc., yet to be completed or items of Work to be corrected.
- b. Upon receipt of Written Notice from Contractor that the Work is substantially complete, Owner's Representative shall promptly make an inspection, and when they find the Work complies with the terms of the Contract and the contract is substantially completed, they will issue a signed and dated certificate, and a list of all items to be completed or corrected, stating that the Work required by this Contract has been substantially completed and is accepted.
- c. Upon substantial completion, the entire balance due and payable to Contractor less 5 percent of the Contract Price, and less a retention based on Owner's Representative's estimate of the fair value for the cost of completing or correcting listed items of Work with specified amounts for each incomplete or defective item of Work shall be made.
- d. The general guarantee period for the Work shall begin on the Final Completion date as approved by Owner's Representative.

- 21.2 Final Completion shall be that point at which all Work has been completed and all defective Work has been corrected.

- 21.3 At the end of the general guarantee period for the entire Contract which has been certified finally completed or substantially completed, Sanborn Head shall make an inspection of all or portions of the Work. When it is found that the Work is satisfactory and that no Work has become defective under the terms of the Contract, Sanborn Head will accept the entire project and make final payment, including the reimbursement of monies retained pursuant to the guarantee period.
- 21.4 If the guarantee inspection discloses any Work as being unsatisfactory, Owner's Representative will give Contractor the necessary instructions for correction of such Work, and Contractor shall immediately execute such instructions. Upon correction of the Work, another inspection will be made which shall constitute the guarantee inspection, provided the Work has been satisfactorily completed.
- 21.5 Before issuance of final payment, Contractor shall certify in writing to Owner's Representative that all payrolls, material bills, and other indebtedness connected with the Work have been paid or otherwise satisfied.
- 21.6 If upon substantial completion, Final Completion is delayed through no fault of Contractor, and Owner's Representative so certifies, Sanborn Head may, without termination of the Contract, make payment of the balance due for that portion of the Work fully completed and accepted. Such payment shall be made under the terms and conditions governing final payment, except that it shall not constitute a waiver of claims.
- 21.7 The acceptance by Contractor of final payment shall release Sanborn Head and Owner from all claims and all liability to Contractor for all things relating to this Work and for every act and neglect of Sanborn Head and Owner and others relating to or arising out of this Work. No payment, however, final or otherwise, shall operate to release Contractor or their sureties from any obligations of the Performance and Payment Bonds under this Contract.

22.0 Insurance

- 22.1 Contractor shall procure and shall maintain during the life of this Contract all insurance required under this article. Owner, Sanborn Head, and Owner's Representatives shall be named as additional insured parties on all General Liability policies. The minimum limits of liability of such insurance shall be as follows:
- a. Commercial General Liability insurance to include contractual liability, explosion, collapse, underground coverages, property damage liability, and personal injury liability of not less than \$2,000,000 for each occurrence (bodily injury and property damage) and a \$5,000,000 minimum aggregate amount.

- b. Statutory Workers' Compensation insurance, and Employer's Liability insurance of at least \$1,000,000 each accident.
- c. Comprehensive automobile liability insurance to include all motor vehicles including owned, hired, borrowed, and non-owned vehicles. Minimum Limits of liability: \$1,000,000 combined single limit for bodily injury and property damage.
- d. Contractor's Pollution Liability with a limit of at least \$2,000,000 per claim and \$4,000,000 in aggregate.

22.2 Contractor shall either:

- a. Require each of his Subcontractors to procure and to maintain during the life of their subcontract commercial general liability insurance and comprehensive automobile liability insurance of the type and in the amounts specified in Articles 22.1.a and 22.1.c; or
- b. Insure the activities of their Subcontractors in his policy.

22.3 The required insurance shall provide adequate protection for Contractor and his Subcontractors, respectively, against damage claims that may arise from Work under this Contract, whether such Work be by the insured or by anyone employed by them and also against any of the special hazards that may be encountered in the performance of this Contract.

22.4 Contractor shall furnish Sanborn Head with certificates showing the type, amount, class of operations covered, effective dates and dates of expiration of policies. Such insurance shall not be canceled or materially altered, except after ten (10) days Written Notice has been received by Sanborn Head and Owner.

22.5 The policies shall be on forms and endorsements approved for use in the State of New Hampshire by the New Hampshire Department of Insurance and issued by insurers licensed in the State of New Hampshire.

23.0 Bonds

23.1 None of the three lowest qualified Bids shall be deemed rejected, notwithstanding acceptance of one of the Bids, until the Contract has been executed by both Sanborn Head and the accepted Bidder.

23.2 Contractor shall within seven (7) business days after the receipt of the Notice of Award furnish Sanborn Head with a Performance Bond and a Payment Bond in penal sums equal to the amount of the Contract Price conditioned upon the performance by Contractor of all undertakings, covenants, terms, conditions and agreements of the Contract Documents, and upon the prompt payment by Contractor to all persons

supplying labor and materials in the prosecution of the Work provided by the Contract Documents. Such Bonds shall be executed by Contractor and a corporate bonding company licensed to transact business in the state in which the Work is to be performed and named on the current list of "Surety Companies Acceptable on Federal Bonds" as published in the Treasury Department Circular Number 570. The expense of these Bonds shall be borne by Contractor.

- 23.3 In the event the successful Bidder fails to execute and deliver the Agreement and to furnish the required contract security and insurance certificates within seven business days of the Notice of Award Owner's Representative may annul the Notice of Award of that Bidder shall be forfeited as liquidated damages.
- 23.4 In the event the successful Bidder has failed to fulfill such promises (and subject to Sanborn Head's right to reject all Bids), Owner's Representative shall issue the Notice of Award to the next lowest responsive, responsible qualified Bidder. Any Bidder so awarded a Contract shall fulfill every stipulation embraced herein as if they were the original party to whom the award was made.
- 23.5 Attorneys-in-fact who sign Performance Bonds or Payment Bonds must file with each Bond a certified and effective dated copy of their power of attorney.

24.0 Subcontracting

- 24.1 Contractor may utilize the services of specialty Subcontractors on those parts of the Work that, under usual contracting practices, are performed by specialty Subcontractors.
- 24.2 Contractor shall be as fully responsible to Sanborn Head for the acts and omissions of their Subcontractors, and of persons either directly or indirectly employed by them, as they are for the acts and omissions of persons directly employed by them.
- 24.3 Contractor shall cause appropriate provisions to be inserted in all subcontracts relative to the Work to bind Subcontractors to Contractor by the terms of the contract documents insofar as applicable to the Work of Subcontractors and to give Contractor the same power as regards terminating any subcontract that Sanborn Head may exercise over Contractor under any provision of the Contract Documents.
- 24.4 Contractor shall not create any contractual relation between any Subcontractor and Sanborn Head or Owner.
- 24.5 Contractor shall not award Work to Subcontractor(s) where the combined value of all subcontracted Work exceeds 50% of the Contract Price, not including transportation and disposal of remediation waste, without prior written consent of Sanborn Head.

25.0 Authority of Owner's Representative

25.1 Owner's Representative shall have the authority to suspend the Work in whole or in part for such periods as they may deem necessary due to the failure of Contractor to carry out provisions of the Contract or for failure of Contractor to suspend Work in weather conditions considered by Owner's Representative to be unsuitable for the prosecution of the Work. Owner's Representative shall give all orders and directions under this Contract, relative to the execution of the Work. Owner's Representative shall determine the amount, quality, acceptability, and fitness of the kinds of work and materials which are to be paid for under this Contract and shall decide all questions which may arise in relation to the Work. Owner's Representative's estimates and decisions shall be final and conclusive, except as otherwise provided. In case any question shall arise between the parties hereto relative to said Contract or Specifications, the determination or decision of Owner's Representative shall be a condition precedent to the right of Contractor to receive any money or payment for Work under this Contract affected to any extent by such question. Owner's Representative shall decide the meaning and intent of any portion of the Specifications and of any Drawings where the same may be found unclear. Any differences or conflicts in regard to their Work which may arise between Contractor under this Contract and other Contractors performing Work for Owner shall be adjusted and determined by Owner's Representative.

- a. The purpose of the above article is not in any way to relieve Contractor of their responsibilities for the safety of workers or general public in the execution of the Work. Attention is drawn to Article 32 of these Conditions that refers to the safety obligations of Contractor.
- b. Owner's Representative, acting on behalf of Owner, has the authority to enforce corrective action for Work not in accordance with the Specifications.
- c. In addition, Owner's Representative, acting on behalf of Owner, is to attempt to verify that the Work is in accordance with the Contract Documents. Owner's Representative is not held responsible, however, for the methods of construction, sequences, schedules, and procedures in the execution of the Work. Owner's Representative does have the opportunity under Article 25.1 to reject the method of construction, work plan schedule, procedures, as they think appropriate.

25.2 Owner's Representative shall appoint assistants and representatives as they desire, and they shall be granted full access to the Work under the Contract. They have the authority to give directions pertaining to the Work, to approve or reject materials, to suspend any Work that is being improperly performed, to make measurements of quantities, to keep records of costs, and otherwise represent Owner's Representative in all matters except as provided below. Contractor may, however, appeal from their decision to Owner's Representative, but any Work done pending

its resolution is at Contractor's own risk. Except as permitted and instructed by Owner's Representative, the assistants and representatives are not authorized to revoke, alter, enlarge, relax, or release any requirements of these Specifications, nor to issue instructions contrary to the Drawings and Specifications. They are not authorized to act as superintendents or foremen for Contractor, or to interfere with the management of the Work by Contractor. Any advice which the assistants or representatives of Owner's Representative may give Contractor shall not be construed as binding Owner's Representative or Owner in any way, nor as releasing Contractor from the fulfillment of the terms of the Contract. All transactions between Contractor and the representatives of Owner's Representative which are liable to protest or where payments are involved shall be made in writing.

26.0 Use of Premises, Removal of Debris, Sanitary Conditions

26.1 In the use of premises or removal of debris, Contractor expressly undertakes at their own expense: to take every precaution against injuries to persons or damage to Property; to maintain sanitary conditions; to store apparatus, materials, supplies and equipment in such orderly fashion at the site of the Work as will not interfere with the progress of Work or the Work of any others; to place upon the Work or any part thereof only such loads as are consistent with the safety of that portion of the Work; to clean up frequently all refuse, rubbish, scrap materials and debris caused by Contractor's operations, to the end that at all times the site of the Work shall present an orderly and workmanlike appearance; before final payment to remove all surplus material falsework, temporary structures, including foundations thereof, plant of any description and debris of every nature resulting from Contractor's operations, and to put the site in an orderly condition; to effect all cutting, fitting or patching of Work required to make the same conform to the Drawings and Specifications and, except with the consent of Owner's Representative, not to cut or otherwise alter the Work of any others; to provide and maintain in a sanitary condition such toilet accommodations for the use of employees as may be necessary to comply with the requirements of the state and local boards of health, or of other bodies or authorities having jurisdiction.

27.0 Estimated Quantities

27.1 Owner's Representative's estimated quantities are indicated on the Bid Schedule. Actual quantities may vary from those indicated. The total Bid Price for each item shall be based on the quantities indicated on the Bid Schedule where provided, or as estimated by Contractor where not provided. No adjustment, either up or down, in unit price for an individual pay item will be considered unless the actual quantity of the pay item required to complete the Work varies by greater than twenty five percent (25%) from that indicated on the Bid Schedule. Claims for Extra Work resulting from changed quantities shall be processed under Article 18.

- 27.2 Should any unit priced item contained on the Bid Schedule be found unnecessary for the proper completion of the Work, Owner's Representative may eliminate such item from the contract and such action shall in no way invalidate this Agreement.

28.0 General Guaranty

- 28.1 With reference to warranties, neither the final certificate of payment nor any provision in the Contract Documents, nor partial or entire occupancy of the premises by Owner, shall constitute an acceptance of Work not done in accordance with the Contract Documents or relieve Contractor of liability in respect to any express warranties or responsibility for faulty materials or workmanship. Contractor shall remedy any defects in the Work and pay for any damage to other Work resulting therefrom, which appear within the warranty period one year or longer if required by the contract, from the certified date of completion or substantial completion of the Work. Sanborn Head will give notice of observed defects within five working days of their discovery.

29.0 Errors and Inconsistencies in Contract Documents

- 29.1 With reference to errors and inconsistency in Contract Documents, any provisions in any of the Contract Documents which may be in conflict with the paragraphs in these General Conditions shall be subject to the following order of precedence for interpretation:
- a. Drawings will govern technical specifications.
 - b. General Conditions will govern Drawings and Technical Specifications.
 - c. Supplemental Conditions will govern General Conditions, Drawings, and Technical Specifications.
- 29.2 Contractor shall take no advantage of any apparent error or omission in the Drawings or Specifications. In the event Contractor discovers such an error or omission, they shall notify Owner's Representative. Owner's Representative will then make such corrections and interpretations as may be deemed necessary for fulfilling the intent of the Drawings and Specifications.

30.0 Notice and Service Thereof

- 30.1 Any notice to Contractor from Sanborn Head relative to any part of this Contract will be in writing and will be considered delivered and the service completed, when said notice is mailed, by email or by certified registered mail, to Contractor at their last given address, or delivered in person to Contractor or their authorized representative on the Work.

31.0 Required Provisions Deemed Inserted

31.1 Each and every provision of law and clause required by law to be inserted in this Contract shall be deemed to be inserted herein and the Contract shall be read and enforced as though it were included herein, and if through mistake or otherwise any such provision is not inserted or is not correctly inserted (example; miswording, etc.), then upon the application of either party the Contract shall forthwith be physically amended to make such insertion or correction.

32.0 Health and Safety Responsibilities

- 32.1 Contractor shall at all times be responsible for the activities of their own employees and agents on the job site with respect to job site safety.
- 32.2 Contractor shall acknowledge its understanding regarding its health and safety responsibilities by reading and signing the “Contractor’s Statement of Understanding Regarding Health and Safety Responsibilities” contained in Exhibit A. Contractor shall comply with all applicable provisions of federal, state, and local health, safety, and training obligations required by law, including 29 CFR Parts 1910 and 1926. Compliance with these health, safety, and training requirements and any other safety practices deemed necessary by Contractor is the sole responsibility of Contractor. Sanborn Head is not in any way responsible for the health, safety, or training of Contractor’s employees.
- 32.3 Contractor warrants that all of its employees who are permitted to engage in hazardous waste operations that could expose them to hazardous substances, safety, or health hazards have obtained the necessary health and safety training and medical surveillance in compliance with 29 CFR 1910.120. Failure to comply with general health and safety practices may be grounds for termination.
- 32.4 Contractor shall prepare a project specific Health and Safety Plan for use by all its employees engaged in the Work. Contractor shall review the plan with all on-site employees and other personnel prior to starting the Work. Contractor shall see that their Subcontractors and vendors are aware of the health and safety risks associated with completion of this project.

33.0 Compliance by Contractor with Laws and Regulations: Equal Employment Opportunity

- 33.1 In connection with the performance of the services, Contractor shall comply with all statues, laws, regulations, and orders of federal, state, county, or municipal authorities which impose any obligation or duty upon Contractor, including, but not limited to civil rights and equal opportunity laws.
- 33.2 During the term of this Agreement, Contractor shall not discriminate against employees or applicants for employment because of race, color, religion, creed, age,

sex, handicap, or national origin, and will take affirmative action to prevent such discrimination.

34.0 Pre-Construction Meeting

34.1 Contractor shall not commence Work until a pre-construction meeting has been held at which representatives of Contractor and Owner's Representative are present. The pre-construction meeting shall be scheduled by Owner's Representative.

35.0 Work Performed at Night and on Weekends and Holidays

35.1 No Work will be permitted at night or on weekends or holidays except as approved in writing by Owner's Representative, and provided such Work is not in violation of a local ordinance. When working at night, Contractor shall provide flood lighting sufficient to ensure the same quality of workmanship and the same conditions regarding safety as would be achieved in daylight.

35.2 Whenever a federal holiday (e.g., Memorial Day or Fourth-of-July) is observed on a Friday or a Monday and during the weekend, Contractor may be required to suspend Work for the 3 calendar days. Prior to the close of Work, the Project site shall be placed in a condition acceptable to Owner's Representative for the comfort and safety of the traveling public. An arrangement shall be made for responsible personnel acceptable to Owner's Representative to maintain the project in the above conditions.

36.0 Laws, Permits, Rules and Ordinances

36.1 Contractor shall keep fully informed of all federal and state laws, all local laws, ordinances, and regulations, and all orders and decrees of tribunals having any jurisdiction or authority, which in any manner affect those engaged or employed on the Work. Contractor shall at all times observe and comply with all such laws, ordinances, regulations, orders, and decrees; and shall protect and indemnify Owner, Sanborn Head & Associates, Inc., and their subcontractors and representatives against any claim or liability arising from or based on the violation of any such law, ordinance, regulation, order, or decree, whether by themselves or their employees. Such laws, rules, and regulations are listed throughout these Contract Documents, and include but are not limited to the New Hampshire Code of Administrative Rules Env-Or 600 Contaminated Site Management, and the New Hampshire Hazardous Waste Rules Env-Wm 500.

36.2 All permits and licenses necessary for the performance of the Work, including coverage under the USEPA National Pollutant Discharge Elimination System (NPDES) Construction General Permit (CGP) for Stormwater Discharges from Construction Sites, including submittal of the Notice of Intent (NOI), shall be obtained by

Contractor. The Contractor may also be responsible for obtaining additional permits that are required as part of the Contract with Streamworks, PLLC.

37.0 Indemnification

- 37.1 To the fullest extent permitted by laws and regulations, Contractor will defend, indemnify, and hold harmless Owner, Sanborn, Head & Associates, Inc., and their consultants, agents, separate contractors and employees from and against all claims, damages, losses, and expenses, direct, indirect or consequential (including but not limited to fees and charges of Engineers, architects, attorneys, and other professionals and court and arbitration costs) arising out of or resulting from the performance of the Work, provided that any such claims, damage, loss or expense is attributable to bodily injury, sickness, disease or death, or to injury to or destruction of tangible property (other than the Work itself) including the loss of use resulting therefrom; and is caused in whole or in part by any negligent or willful act or omission or breach of Contract by Contractor, and Subcontractor, vendor, or anyone directly or indirectly employed by any of them to perform or furnish any of the Work or anyone for whose acts any of them may be liable.
- 37.2 In any and all claims against Owner or Owner's Representative, or any of their agents of employees, by any employees of Contractor, and Subcontractor, anyone directly or indirectly employed by any of them, or anyone for whose acts any of them may be liable, the indemnification obligation shall not be limited in any way by any limitation on the amount or type of damages, compensation or benefits payable under workers' or workman's compensation acts, by disability benefit or other employee benefit acts, and shall survive final completion and acceptance of the Work.

P:\4000s\4088.012\Source Files\Bid Documents\Contracting Documents\202511-GeneralConditions.docx

**EXHIBIT A
TO GENERAL CONDITIONS
FOR CONTRACTOR SERVICES**

**CONTRACTOR'S STATEMENT OF UNDERSTANDING
REGARDING HEALTH AND SAFETY RESPONSIBILITIES**

Each Contractor employed by Sanborn, Head & Associates, Inc. (Sanborn Head) is responsible for all aspects of the health and safety of its employees and equipment, including identification of possible health and safety issues related to the project. Sanborn Head will make its health and safety plan available to each Contractor. This health and safety plan will be provided for informational purposes only, however, and each Contractor (including subcontractors) is responsible for developing its own health and safety program for its activities on site.

Contractor confirms that all its on-site employees are certified to work at sites where there is a potential for exposure to hazardous substances, or other potential health and safety hazards. Contractor also confirms that these employees have had the proper health and safety training and are involved in an appropriate medical monitoring program pursuant to OSHA:

1910.120 Hazardous Waste Operations and Emergency Response
1926.103 Respiratory Protection
1926.52 Occupational Noise Protection
1926.59 Hazard Communication

and any other applicable portions of OSHA. Contractor shall provide at Sanborn Head's request copies of all applicable certification prior to commencement of work.

If it comes to the attention of Sanborn Head, that Contractor's site activities are in violation of OSHA or other applicable regulations or pose a danger to the health or safety of on-site personnel or the general public, Sanborn Head may inform Contractor of the need to correct such activities. If Contractor does not comply with general health and safety procedures or those specified above, Sanborn Head may terminate its Agreement with Contractor immediately.

It should be clearly noted that the presence of Sanborn Head personnel at the site does not indicate that Sanborn Head is responsible to ensure or oversee that Contractor complies with appropriate health and safety requirements.

Signatory indicates that he/she is authorized to endorse this agreement for Contractor:

Firm: _____

Name (Print): _____

Title: _____

Signature: _____

Date: _____

ATTACHMENTS

100% Design Drawings – Floodplain Restoration

WOODS WOOLEN MILL FLOODPLAIN RESTORATION

100% DESIGN PLANS

FORMER WOODS WOOLEN MILL SITE ON THE CONTOOCOOK RIVER IN HILLSBOROUGH, NEW HAMPSHIRE

COUNTY

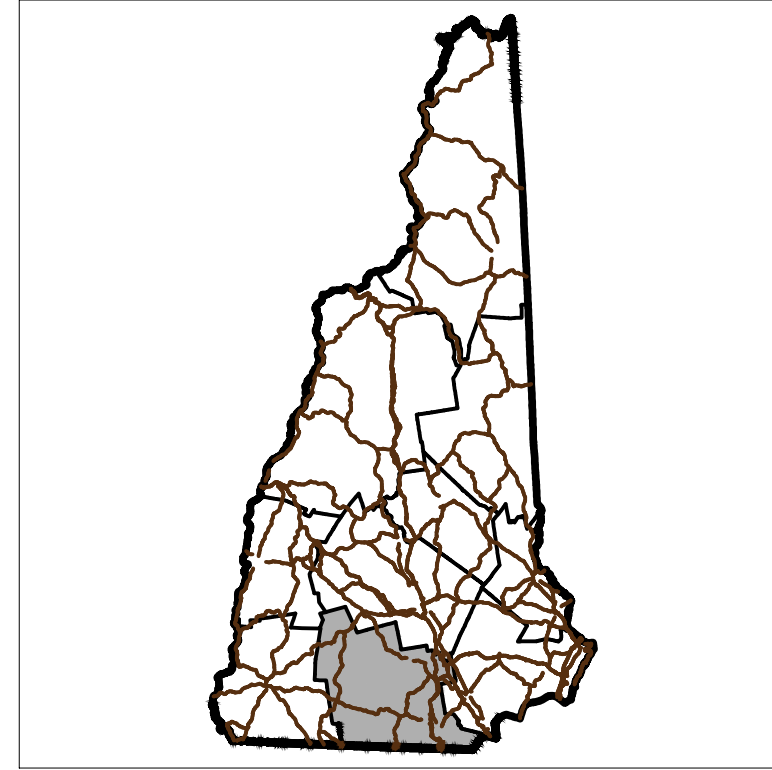

TOWN

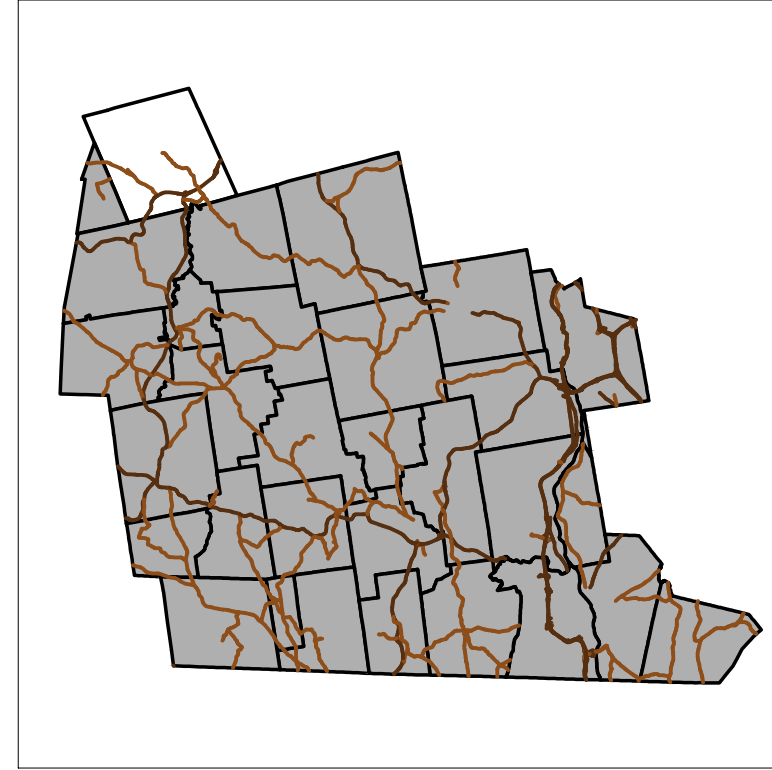

SITE



VICINITY MAP
NOT TO SCALE



FORMER MILL SITE

LIST OF SHEETS

NO	SHEET ID	SHEET TITLE
1.	NOTES	PROJECT NOTES
2.	OVIEW	PROJECT OVERVIEW
3.	X-OVIEW	EXISTING SITE OVERVIEW
4.	P-OVIEW	PROPOSED SITE OVERVIEW
5.	P-SITE	PROPOSED SITE COMPONENTS
6.	P-GRAD	PROPOSED SITE GRADING
7.	XSECS	SITE CROSS SECTIONS
8.	PROF	SITE PROFILE & REFERENCE SECTIONS
9.	XS-TYP	TYPICAL SITE SECTION
10.	D1	RIVERSIDE RETAINING WALL DETAIL
11.	D2	UPLAND RETAINING WALL DETAIL

NOTES

- DATUMS FOR THE PROJECT ARE NH STATE PLANE IN FEET FOR HORIZONTAL AND NAVD88 FOR VERTICAL.
- THE PROJECT PROPOSES TO RESTORE 13,765 SQUARE FEET OF FLOODPLAIN ALONG 390 FEET OF STREAM BANK.
- THESE PLAN SHEETS DESCRIBE THE FLOODPLAIN RESTORATION DESIGN FOR THE SITE. CONSTRUCTION FOR THE PROJECT WILL OCCUR SIMULTANEOUSLY WITH REMEDIATION EFFORTS. REFER TO THE REMEDIATION DESIGN SHEETS BY SANBORN HEAD DATED JUNE 2025.



GENERAL NOTES

1. CONTACTS FOR THIS PROJECT INCLUDE:
 - 1.1. JOEL BALLESTERO – STREAMWORKS, PLLC
PROJECT ENGINEER
970-556-7552
 - 1.2. LAURA BUONO – TOWN OF HILLSBOROUGH, NH
TOWN ADMINISTRATOR
603-464-7970
 - 1.3. JESSICA SCHULZ – NHDES WETLANDS BUREAU
PROJECT REVIEW AND PERMITTING
603-271-4188
 - 1.4. MINDY BUBIER – NHDES HAZARDOUS WASTE REMEDIATION BUREAU
PROJECT PARTNER AND REVIEW
603-271-2183
 - 1.5. HEIDI CAPROOD – SANBORN, HEAD AND ASSOCIATES
PROJECT PARTNER
603-415-6149
2. UNLESS OTHERWISE STATED, THE GLOBAL DATUMS TO WHICH ALL ELEVATIONS ARE REFERENCED ARE:
 - 2.1. HORIZONTAL: NAD83 – NEW HAMPSHIRE STATE PLANE, US SURVEY FEET
 - 2.2. VERTICAL: NORTH AMERICAN VERTICAL DATUM OF 1988 (NAVD88), FEET
3. THIS SITE IS A FORMER WOOLEN MILL AND HAS UNDERGONE TWO ROUNDS OF HAZARDOUS WASTE CLEAN-UP. CONTAMINATED SOILS MAY STILL EXIST AT THE SITE – THE SELECTED CONTRACTOR AND ALL PERSONNEL PRESENT DURING EARTH WORK ACTIVITY MUST BE HAZWOPER CERTIFIED.
4. PRIMARY PROJECT CONTACTS SHOULD BE NOTIFIED IMMEDIATELY SHOULD ANY ISSUES ARISE DURING CONSTRUCTION.
5. IN TOTAL, THIS PROJECT PROPOSES:
 - 5.1. A TOTAL RESTORATION AREA OF **13,765** sf
 - 5.1.1. 11,925 sf RESTORED FLOODPLAIN
 - 5.1.2. 1,840 sf RESTORED UPLAND/RIPARIAN
 - 5.2. A TOTAL STREAM BANK IMPROVEMENT LENGTH OF **390** ft (INCLUDING THE TWO SECTIONS AT THE NORTH AND SOUTH ENDS – 20’ AND 16’, RESPECTIVELY – WHICH RUN PERPENDICULAR TO THE STREAM
 - 5.2.1. 374 ft HARD BANK MADE SOFTER
 - 5.2.2. 16 ft RESTORED/CONSTRUCTED BANK
 - 5.3. A TOTAL REVEGETATION AREA OF **13,983** sf
 - 5.3.1. 4,495 sf LOW FLOODPLAIN AREA
 - 5.3.2. 6,859 sf HIGH FLOODPLAIN AREA
 - 5.3.3. 2,179 sf UPLAND/RIPARIAN AREA
 - 5.4. NEWLY RECONNECTED FLOODPLAIN AREA (LAND TO BE INUNDATED DURING BANKFULL EVENT) TOTALING **9,816** sf
 - 5.5. TOTAL LAND AREA (OUTSIDE ORDINARY WATER ELEVATION) WITHIN PROJECT PARCEL TO BE PUT INTO CONSERVATION OF **34,855** sf

CONSTRUCTION NOTES

6. THIS SET OF RESTORATION PLANS MUST BE USED IN CONJUNCTION WITH THE REMEDIATION SET OF PLANS BY SANBORN HEAD, DATED JUNE 2025.
7. BEFORE PERFORMING ANY CONSTRUCTION, CONTACT DIGSAFE AT THE NUMBER PROVIDED TO THE RIGHT, OR ONLINE, TO ENSURE THE LOCATION OF ANY UNDERGROUND UTILITIES, IF THERE ARE ANY.
8. CONSTRUCTION MAY ONLY OCCUR WHILE UNDER THE SUPERVISION OF A PROJECT ENGINEER, UNLESS PERMISSION HAS BEEN GRANTED OTHERWISE.
9. IT IS ANTICIPATED THAT SOME ALTERATIONS TO THE MEANS OF CONSTRUCTION AND/OR FINAL DESIGN WILL BE REQUIRED WHILE CONSTRUCTION IS OCCURRING (INSTANCES WHERE EFFORTS MAY BE ENHANCED OR STREAMLINED, BENEFITING THE PROJECT). IT IS ASSUMED THAT THESE INSTANCES WILL BE ALLOWABLE UNDER THE GUISE OF ADAPTIVE MANAGEMENT, PERMISSION GIVEN UNDER THE WETLAND PERMIT. THESE DECISIONS WILL BE MADE AND APPROVED ONLY BY AN AUTHORIZED PROFESSIONAL, AND REPORTED TO REGULATORY AGENTS.
10. THERE IS A STATE-OWNED PARCEL BISECTING THE PROJECT PARCEL WHICH ENCOMPASSES MOSTLY THE FLAT AREA ABOVE THE UPLAND RETAINING WALL. THIS AREA MAY BE USED FOR ACCESS AND PARKING, BUT NOT STAGING/STOCKPILING.
11. STAGING/STOCKPILING IS EXPECTED TO BE DONE WITHIN THE LIMITS OF EARTHWORK, SITED AND MOVED AS NECESSARY AS THE PROJECT PROGRESSES.
12. ALL CONSTRUCTION ACTIVITY IS LIMITED TO OUTSIDE ANY WETLANDS, EXCEPT AS SHOWN ON THESE SHEETS, EXCEPT FOR THE INSTALLATION, MAINTENANCE, AND REMOVAL OF A TURBIDITY CURTAIN IN THE RIVER.
13. SOILS AT THE SITE ARE ASSUMED TO BE CONTAMINATED AND SHOULD REMAIN ON SITE TO A PRACTICAL EXTENT BEFORE BEING CONSIDERED FOR REMOVAL.
14. BEDROCK IS COMMON IN THE AREA AND MAY BE ENCOUNTERED DURING CONSTRUCTION. IF BEDROCK ENCROACHES INTO PROPOSED GRADING, ADAPTIVE MANAGEMENT WILL BE USED TO ADJUST THE PLAN EITHER BY REMOVAL OF THE ROCK OR LIGHT ALTERATION TO THE SITE GRADING.
15. THE UPLAND LIMIT OF RESTORATION SHALL BE AT LEAST 40 FEET (TYP)

- FROM THE RIVERSIDE RETAINING WALL, THOUGH IT SHOULD BE MAXIMIZED TO THE LIMIT REQUIRED FOR THE UPLAND RETAINING WALL TOE PROTECTION SLOPE. DUE TO RUBBLE AND MATERIAL AGAINST THE TOE OF THE UPLAND RETAINING WALL, THE LOCATION AND DEPTH OF THE BASE IS UNKNOWN.
16. THE BASE OF THE UPLAND RETAINING WALL SHOULD NOT BE EXCAVATED AND EXPOSED TO ENSURE STABILITY. RATHER, LEAVE MATERIAL AT THE BASE AND BACKFILL AS SHOWN ON THE PLANS TO CREATE A SLOPE AT THE TOE FOR PROTECTION WITH A TOP ELEVATION AROUND 578.0’.
17. PORTIONS OF THE RIVERSIDE RETAINING WALL WILL BE REMOVED TO ENSURE THE FLOODPLAIN AT THE RIVER IS ALLOWED FLOOD ACCESS AT ELEVATION 574.0’.
18. THE UPLAND RETAINING WALL SHALL HAVE LOOSE MATERIAL REMOVED OR REGROUTED, ALONG WITH ANY GAPS FOR THE LENGTH OF THE WALL REMAINING. A SMALL SECTION (~20’) SHALL BE REBUILT USING MATERIALS FROM ONSITE, WITH SMALLER ROCKS FILLING GAPS OF LARGER ONES, ALL GROUTED TOGETHER. IT IS ASSUMED THAT THE LOWER HALF OF THE WALL STILL EXISTS BELOW FILL PLACED AT THE REMOVED SECTION, USED FOR ACCESS DURING FORMER EPA CLEANUP.
19. CONSTRUCTION ACCESS SHALL BE FROM THE LARGE PILE OF MATERIAL NEAR THE NORTHERN SECTION, SO THE SITE MAY BE CONSTRUCTED FIRST BY COMPLETING THE NORTHERN SECTION, THEN BEGINNING FROM THE SOUTHERN END FINISHING ALL EFFORTS IN SEGMENTS WORKING BACK TO THE ACCESS POINT.
20. THOUGH SHOWN HAVING THE TOP 18 INCHES MINIMUM BACKFILL OF LOAM, MORE BACKFILL MAY BE REQUIRED IN AREAS WHERE RUBBLE IS FOUND. EITHER OVER-EXCAVATE RUBBLE AND BACKFILL, OR BACKFILL OVER RUBBLE AND WASH IN MATERIAL TO FILL ALL VOIDS AND AVOID SETTLING.
21. FINAL GRADING OF THE FLOODPLAIN SURFACE SHOULD BE DONE ROUGHLY, LESS LINEAR IN FASHION, WITH SLIGHT HUMPS AND DIPS ALLOWED MIMICKING NATURAL CONDITIONS. DO NOT OVER-COMPACT SOIL, AT MOST USING THE BUCKET OF AN EXCAVATOR TO TAMP DOWN. PLACE HABITAT FEATURES LIKE LARGE BOULDERS AND LOGS LAID ON THE SURFACE, AT RANDOM, AT A RATE OF ABOUT 1 PER 500 SQUARE FEET.
22. AFTER CONSTRUCTION OF THE RESTORED FLOODPLAIN HAS BEEN COMPLETE AND THE ACCESS ROAD HAS BEEN REMOVED, DIRECT RUNOFF TO THE NORTH, AWAY FROM THE UPLAND RETAINING WALL TO PREVENT STORMWATER FROM CHANNELING AND CAUSING EROSION TO THE SITE. THIS MAY BE DONE BY CUTTING A SLIGHT SWALE AND/OR ADDING A SLIGHT BERM.

EROSION AND SEDIMENT CONTROL NOTES

23. ALL EROSION CONTROL AND TEMPORARY ACCESS ROAD MEASURES SHALL BE FULLY REMOVABLE UPON COMPLETION OF THE PROJECT.
24. EROSION AND SEDIMENT CONTROL SHALL BE PLACED AT THE SITE BEFORE BEGINNING ANY CONSTRUCTION ACTIVITIES, AND SHOULD BE INSPECTED AT LEAST ONCE A WEEK, OR AFTER ANY STORM TOTALING 0.25” OF RAIN OR MORE. SHOULD ANY MAINTENANCE BE REQUIRED, IT SHALL BE PERFORMED BEFORE CONTINUING ANY CONSTRUCTION.
25. THE EXACT LOCATION OF REQUIRED EROSION MEASURES NECESSARY DURING CONSTRUCTION SHALL BE FULLY DETERMINED IN THE FIELD BY THE SITE ENGINEER, SHALL CONFORM TO NHDES STANDARDS, PLACED ON ALL SLOPES DRAINING AWAY FROM ANY CONSTRUCTION AREAS.
26. ALL EROSION CONTROL MEASURES SHALL BE FULLY REMOVED AND DISCARDED OF PROPERLY AFTER COMPLETING ALL CONSTRUCTION.
27. ALL LANDS DISTURBED BY EROSION CONTROL AND ACCESS SHALL BE RESTORED TO PRE-CONSTRUCTION CONDITIONS OR BETTER WHERE APPLICABLE.
28. THE CONTRACTOR IS RESPONSIBLE FOR MAINTAINING, ENHANCING, OR OTHERWISE ENSURING THE PRIMARY CONSTRUCTION ACCESS TO THE STAGING/STOCKPILING FOLLOWING THE EXISTING GRAVEL ROAD IS IN GOOD WORKING CONDITION.
29. THE CONTRACTOR IS RESPONSIBLE FOR INSTALLING AND MAINTAINING CONSTRUCTION ENTRANCES, ACCESS PATHS, AND STAGING/STOCKPILING INCLUDING MINIMIZING ANY RUNOFF.
30. A TURBIDITY CURTAIN SHALL BE INSTALLED IN THE RIVER ALONG THE RIVERSIDE RETAINING WALL, BEGINNING AT THE LARGE ROCK PIER TO THE SOUTH, BEYOND THE LIMIT OF CONSTRUCTION TO THE NORTH. IT IS NOT REQUIRED AT ALL TIMES, BUT SHALL BE IN PLACE DURING MATERIAL CAPPING AT THE NORTH END, AND DURING REMOVAL/RECONSTRUCTION OF THE RIVERSIDE RETAINING WALL, AT A MINIMUM.
 - 30.1. ALTERNATIVELY, OTHER METHODS MAY BE PROPOSED TO PREVENT OR CONTROL THE LOSS OF MATERIAL INTO THE RIVER OR ALTERNATIVE MEANS OF COMPLETING THE WORK WHICH ELIMINATE THE CHANCE OF MATERIAL ENTERING THE RIVER.
31. WOOD CHIP BERM EROSION CONTROL IS PREFERRED FOR WORK AROUND THE RESTORATION AREA OF THE SITE, DUE TO THE UNEVEN GROUND CONSISTING OF RUBBLE AND BEDROCK, WHERE EROSION CONTROL SOCK MAY BE DIFFICULT TO INSTALL AND AFFIX TO THE GROUND.
32. SANDBAG BERMS SHALL BE INSTALLED AT THE SOUTHERN END OF THE

- PROJECT, WHERE SHOWN, TO HELP PROTECT ACTIVE CONSTRUCTION AGAINST INTERMITTENT HIGHER WATER STAGES.
33. DEWATERING WILL BE NECESSARY AT THE NORTH AND SOUTH ENDS WHERE LOW LANDS WILL BE FILLED. DEWATERING PLANS ARE THE RESPONSIBILITY OF THE CONTRACTOR.

PLANTING NOTES

34. PLANTING SPECIES SHOWN HERE ARE NATIVE, BENEFICIAL SPECIES TO THE WILDLIFE AND HABITAT OF THE RIVER SYSTEM.
35. EXTENDED DROUGHT MAY NECESSITATE PERIODIC WATERING TO ENSURE SURVIVABILITY. THIS MAY BE DONE USING A SUMP PLACED IN THE RIVER.
36. ALL DISTURBED LANDS SHALL BE OVER-SEEDED WITH A NATIVE CONSERVATION WILDFLOWER/GRASS SEED MIX.
37. ALL DISTURBED LANDS ON THE FLOODPLAIN AND GRADED SLOPES LEADING UPLAND SHALL BE STABILIZED USING FULLY-BIODEGRADABLE FABRICS AND FASTERNERS (WOOD OR BIODEGRADABLE STAKES).
 - 37.1. ALONG STEEP SLOPES (GREATER THAN 3:1: UPLAND SLOPES DISTURBED, ALONG THE TOE OF THE UPLAND RETAINING WALL), THIS SHALL CONSIST OF A HEAVY WEIGHT COIR BLANKET (SIMILAR TO EROSIONTECH ETC-100-BN). SEEDING MUST OCCUR PRIOR TO THIS BEING INSTALLED.
 - 37.2. FOR SLIGHTER SLOPES (PRIMARILY THE REGRADED FLOODPLAIN), THIS SHALL CONSIST OF A MEDIUM WEIGHT COIR NET (SIMILAR TO EAST COAST EROSION CONTROL EC-7Y COIR MAT). SEEDING AND PLANTING MAY OCCUR AFTER THIS IS INSTALLED.
38. HIGH FLOODPLAIN TREE SPECIES WILL PRIMARILY CONSIST OF SMALL TO MEDIUM SIZED (15-50’ WHEN GROWN) TREES WHICH ARE INUNDATION- AND SHADE-TOLERANT. GROUND COVER SPECIES HERE MAY BE PLANTED OR SEEDED.
 - 38.1. SPECIES MAY INCLUDE: WHITE SPRUCE (*Picea glauca*), AMERICAN HOPHORNBEAM (*Carpinus caroliniana*), BLACK BIRCH (*Betula lenta*), BLACK CHERRY (*Prunus serotina*), BLACK SPRUCE (*Picea mariana*), BLACK WILLOW (*Salix negra*), POPLAR aka QUAKING ASPEN (*Populus tremuloides*), AND STRIPED MAPLE (*acer pensylvanicum*). OTHER SPECIES MAY BE INSTALLED ONLY AFTER REGULATORY REVIEW AND APPROVAL.
 - 38.2. SPECIES INSTALLED IN THIS PLANTING ZONE SHOULD CONSIST OF MINIMUM 15 GALLON STOCK (6-12’ TALL) TO HELP ENSURE SURVIVABILITY.
 - 38.3. PLANT SPECIES AT A RATE OF 1 PER 200 SQUARE FEET, PLANTED IN A RANDOM FASHION AND NOT ON A GRID, INTERMIXING SPECIES.
 - 38.4. SUPPLEMENTAL INSTALLATION OF LARGER SPECIES FROM THE LOW FLOODPLAIN PLANTING ZONE MAY BE INCORPORATED WITHIN THE FIRST 10’ OF THE RECONSTRUCTED BANK.
 - 38.5. INSTALLATION OF THESE PLANTS MAY REQUIRE SUPPLEMENTAL BACKFILL WITH LOAM TO ENSURE THE ROOT BALL IS SURROUNDED WITH MATERIAL SUITABLE FOR GROWTH.
 - 38.6. INSTALL PROPER ANCHORING PER SUPPLIER’S RECOMMENDATIONS.
39. LOW FLOODPLAIN VEGETATION SPECIES SHALL PRIMARILY CONSIST OF SHRUBS AND SHRUB-TREES WITH FAST GROWTH RATES WHICH ARE TOLERANT TO FREQUENT INUNDATION.
 - 39.1. SPECIES MAY INCLUDE: RED OSIER DOGWOOD (*Cornus stolonifera*), SILKY DOGWOOD (*Cornus amomum*), GRAY DOGWOOD (*Cornus racemosa*), AMERICAN PUSSY WILLOW (*Salix discolor*), AND SPECKLED ALDER (*Alnus incana*). OTHER SPECIES MAY BE INSTALLED ONLY AFTER REGULATORY REVIEW AND APPROVAL.
 - 39.2. THESE PLANTS SHALL BE IN THE FORM OF 1-5 GALLON CONTAINERS TO HELP ENSURE SURVIVABILITY.
 - 39.3. PLANTING RATES FOR THIS ZONE SHOULD BE 1 PER 40 SQUARE FEET PLANTED IN A RANDOM FASHION AND NOT ON A GRID, INTERMIXING SPECIES.
 - 39.4. SOME OF THESE (LESS THAN 20%) MAY BE SUBSTITUTED INSTEAD USING LIVESTAKES. IF SUBSTITUTED, DO SO AT A RATIO OF 10:1 – FOR EVERY 1 CONTAINER PLANT SUBSTITUTED, INSTALL 10 LIVESTAKES.
40. VEGETATION DENSITIES WERE OBSERVED FROM NEARBY LOCATIONS. MAINTAINING A MINIMUM OF THESE DENSITIES FOR FIVE YEARS FOLLOWING CONSTRUCTION IS A GOAL OF THE PROJECT. THEREFORE, THE HIGH (TREES) AND LOW (SMALL TREES AND SHRUB-TREES) FLOODPLAIN PLANTING RATES ARE INTENTIONALLY MORE DENSE THAN OBSERVED TO PROMOTE VEGETATIVE SUCCESS. THESE DENSITIES WERE FOUND TO BE:
 - 40.1. HIGH FLOODPLAIN: ONE PLANT PER 200 SQUARE FEET
 - 40.2. LOW FLOODPLAIN: ONE PLANT PER 100 SQUARE FEET
41. GROUND COVER SHALL BE AT LEAST 90% PRIOR TO FINAL CLOSEOUT OF CONSTRUCTION TO STABILIZE THE FLOODPLAIN, AND SHOULD BE MAINTAINED FOR THE FIVE YEARS FOLLOWING CONSTRUCTION.

GENERAL CONSTRUCTION SEQUENCE

- **DETAILED CONSTRUCTION SEQUENCE SHALL BE PROVIDED BY THE CONTRACTOR, AS DETERMINED TO BEST FIT THEIR CONSTRUCTION PLANS AND METHODS, AND SHALL BE REVIEWED AND APPROVED BY ALL PERMITTING AGENCIES, AND ALL OTHER PROJECT PARTICIPANTS.
- A. SET UP AND CLEARLY DELINEATE STAGING/STOCKPILING AREAS, INSTALLING ANY AND ALL EROSION CONTROLS AND CONSTRUCTION FENCE IN THE AREA.
 - B. CLEAR UNMARKED TREES (MARKED ONES SHALL REMAIN) AND STOCKPILE MATERIALS – LARGER TRUNKS LIMBED AND KEPT INTACT FOR HABITAT FEATURES, ALL OTHER WOOD CHIPPED FOR USE IN EROSION CONTROL. FULLY REMOVE AND DISPOSE OF ALL INVASIVE SPECIES.
 - C. CONSTRUCT ACCESS RAMP AND INSTALL REMAINING SITE EROSION CONTROL MEASURES AS SPECIFIED.
 - D. LEAVING THE RIVERSIDE RETAINING WALL INTACT, REMOVE ALL MATERIALS (ROCK RUBBLE, CONCRETE, CONTAMINATED SOIL, CLEAN BACKFILL, BEDROCK) FROM WITHIN THE RESTORATION AREA DOWN TO SPECIFIED FLOOR OR AS DIRECTED BY ENGINEER. STOCKPILE MATERIALS TO BE REUSED (ROCK RUBBLE), AND DISPOSE OF ALL OTHER MATERIAL (BEDROCK, CONCRETE, CONTAMINATED SOIL).
 - E. RESTORE AND RECONSTRUCT UPLAND RETAINING WALL AS SPECIFIED USING MORTAR AND STOCKPILED BOULDERS/ROCKS.
 - F. AT THE SAME TIME, REMOVE MATERIAL FROM RIVERSIDE RETAINING WALL AND RECONSTRUCT AS SPECIFIED.
 - G. BACKFILL EXCAVATED LANDS WITH CLEAN FILL TO FINAL SUBGRADE.
 - H. BEGINNING AT THE SOUTH END, COMPLETE FINAL GRADING IN SECTIONS, ADDING HABITAT FEATURES (TRUNKS, BOULDERS) THEN SEED, PLANT, AND STABILIZE EACH DAY.
 - I. COMPLETE ALL RESTORATION ACTIVITY, MOVING NORTHWARD. DECONSTRUCT ACCESS ROAD AND REGRADE THE LAND TO PREVIOUS CONDITIONS.
 - J. STABILIZE AND RESTORE ALL REMAINING IMPACTED LANDS. REMOVE EROSION CONTROL MEASURES AND DISPOSE OF ALL TRAPPED MATERIAL APPROPRIATELY.

DESIGNED BY: JCB, TPB	DRAWN BY: JCB	CHECKED BY: TPB	DATE: 06 NOV 2025
			
NOTES			
DATE			
REVISION #			
SHEET TITLE	PROJECT NOTES		
SHEET SET	100% DESIGN SHEETS		
PROJECT NAME	RIPARIAN FLOODPLAIN RESTORATION		
PROJECT LOCATION	FORMER WOODS WOOLEN MILL, HILLSBOROUGH NH		
SHEET ID	NOTES		
SHEET NUMBER	01	OF	11



DESIGNED BY: JCB, TPB
 DRAWN BY: JCB
 CHECKED BY: TPB
 DATE: 06 NOV 2025



REVISION #	DATE	NOTES

PROJECT OVERVIEW
 100% DESIGN SHEETS
 RIPARIAN FLOODPLAIN RESTORATION
 FORMER WOODS WOOLEN MILL, HILLSBOROUGH NH

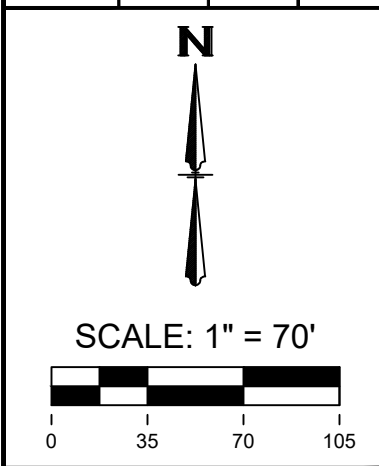

SHEET ID: **OVIEW**
 SHEET NUMBER: **02** OF **11**



DESIGNED BY: JCB, TPB	DRAWN BY: JCB	CHECKED BY: TPB	DATE: 06 NOV 2025
REVISION #:	DATE:	NOTES:	
SHEET TITLE EXISTING SITE OVERVIEW			
SHEET SET 100% DESIGN SHEETS			
PROJECT NAME RIPARIAN FLOODPLAIN RESTORATION			
PROJECT LOCATION FORMER WOODS WOOLEN MILL, HILLSBOROUGH NH			
SCALE: 1" = 30' 			
SHEET ID: X-OVIEW			
SHEET NUMBER: 03 OF 11			

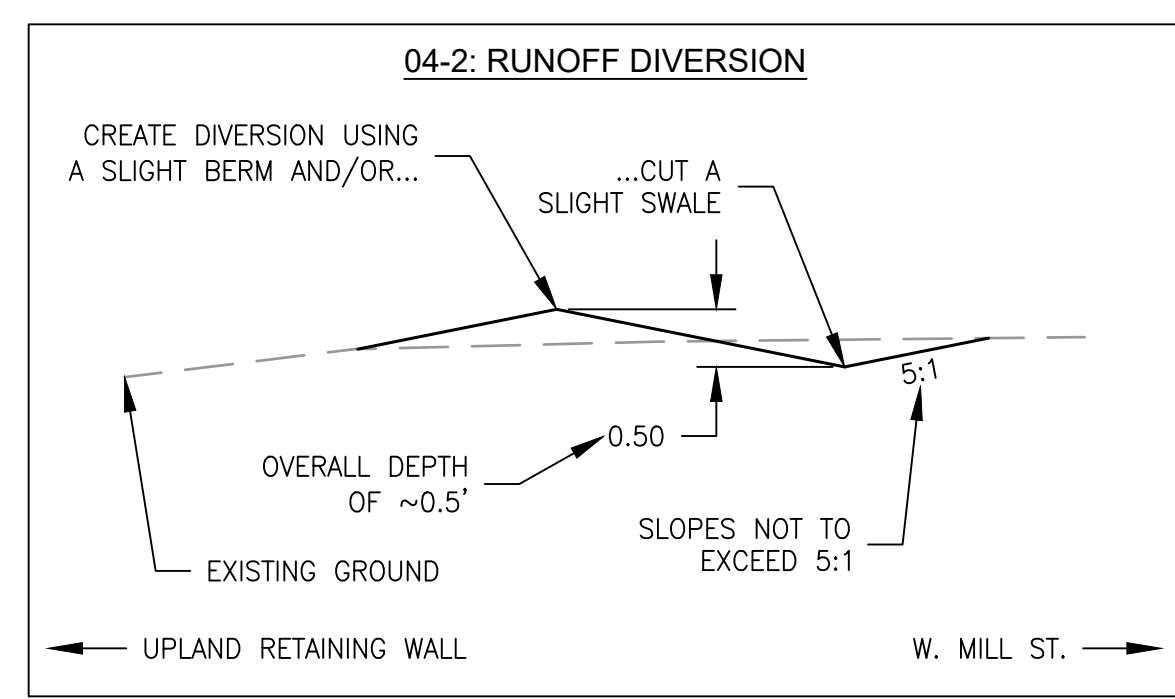
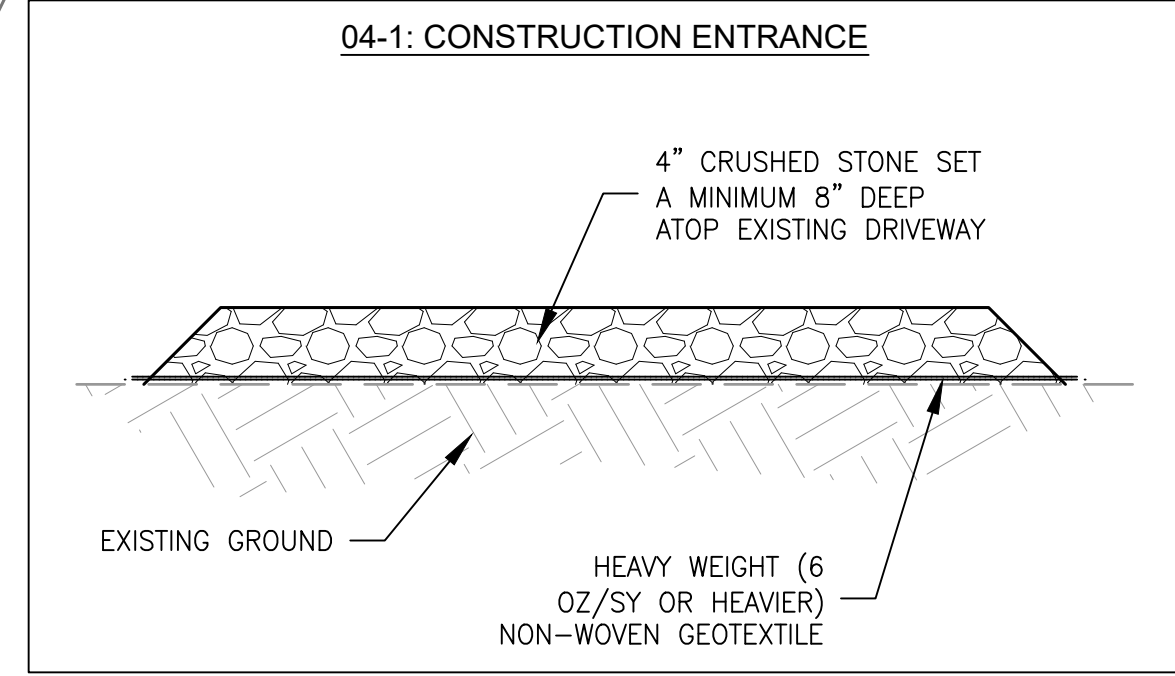
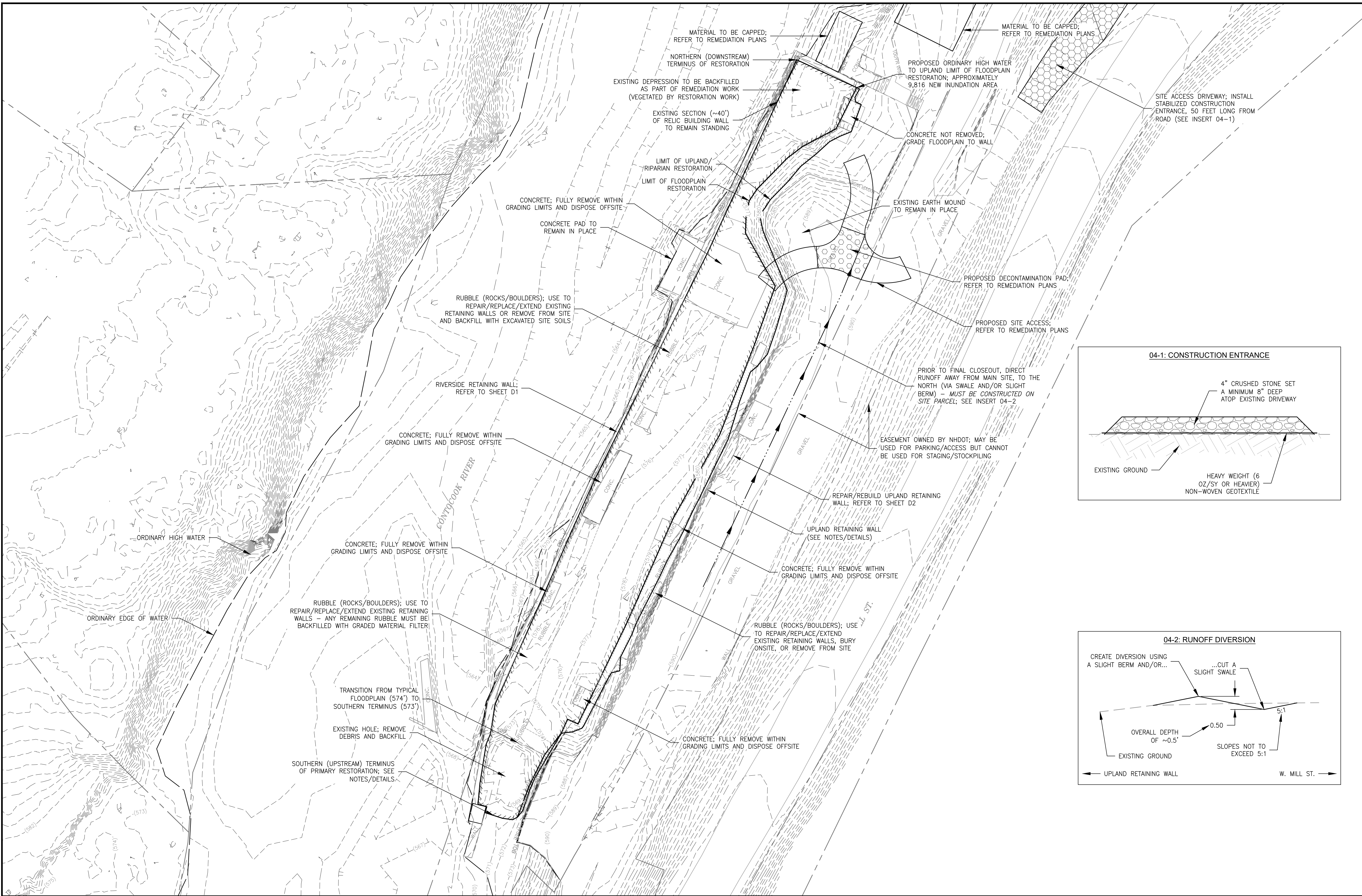

DESIGNED BY: JCB, TPB
 DRAWN BY: JCB
 CHECKED BY: TPB
 DATE: 06 NOV 2025



REVISION #	DATE	NOTES

PROPOSED SITE OVERVIEW

100% DESIGN SHEETS

RIPARIAN FLOODPLAIN RESTORATION

FORMER WOODS WOOLEN MILL, HILLSBOROUGH NH

SHEET TITLE: PROPOSED SITE OVERVIEW

SHEET SET: 100% DESIGN SHEETS

PROJECT NAME: RIPARIAN FLOODPLAIN RESTORATION

PROJECT LOCATION: FORMER WOODS WOOLEN MILL, HILLSBOROUGH NH

SCALE: 1" = 20'

0 10 20 30

SHEET ID: P-OVIEW

SHEET NUMBER: 04 OF 11

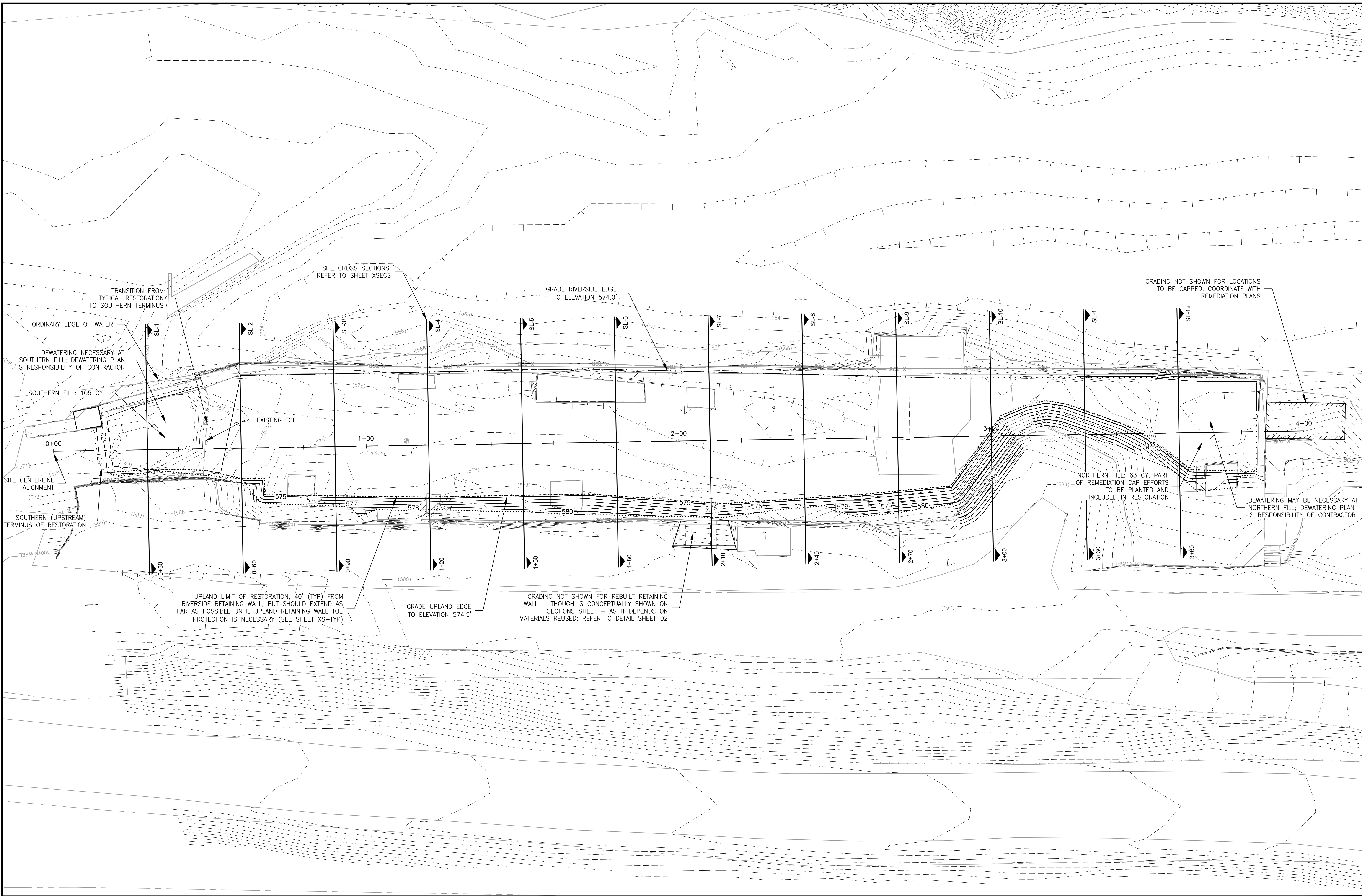

DESIGNED BY: JCB, TPB
 DRAWN BY: JCB
 CHECKED BY: TPB
 DATE: 06 NOV 2025



REVISION #	DATE	NOTES

PROPOSED SITE GRADING
 100% DESIGN SHEETS
 RIPARIAN FLOODPLAIN RESTORATION
 FORMER WOODS WOOLEN MILL, HILLSBOROUGH NH

SHEET TITLE: PROPOSED SITE GRADING
 SHEET SET: 100% DESIGN SHEETS
 PROJECT NAME: RIPARIAN FLOODPLAIN RESTORATION
 PROJECT LOCATION: FORMER WOODS WOOLEN MILL, HILLSBOROUGH NH

SCALE: 1" = 14'

SHEET ID: P-GRAD
 SHEET NUMBER: 06 OF 11

TRANSITION FROM TYPICAL RESTORATION TO SOUTHERN TERMINUS

ORDINARY EDGE OF WATER

DEWATERING NECESSARY AT SOUTHERN FILL; DEWATERING PLAN IS RESPONSIBILITY OF CONTRACTOR

SOUTHERN FILL: 105 CY

SITE CENTERLINE ALIGNMENT

SOUTHERN (UPSTREAM) TERMINUS OF RESTORATION

EXISTING TOB

UPLAND LIMIT OF RESTORATION; 40' (TYP) FROM RIVERSIDE RETAINING WALL, BUT SHOULD EXTEND AS FAR AS POSSIBLE UNTIL UPLAND RETAINING WALL TOE PROTECTION IS NECESSARY (SEE SHEET XS-TYP)

GRADE RIVERSIDE EDGE TO ELEVATION 574.0'

GRADE UPLAND EDGE TO ELEVATION 574.5'

GRADING NOT SHOWN FOR REBUILT RETAINING WALL - THOUGH IS CONCEPTUALLY SHOWN ON SECTIONS SHEET - AS IT DEPENDS ON MATERIALS REUSED; REFER TO DETAIL SHEET D2

GRADING NOT SHOWN FOR LOCATIONS TO BE CAPPED; COORDINATE WITH REMEDIATION PLANS

NORTHERN FILL: 63 CY, PART OF REMEDIATION CAP EFFORTS TO BE PLANTED AND INCLUDED IN RESTORATION

DEWATERING MAY BE NECESSARY AT NORTHERN FILL; DEWATERING PLAN IS RESPONSIBILITY OF CONTRACTOR

SITE CROSS SECTIONS; REFER TO SHEET XSECS

SL-1, SL-2, SL-3, SL-4, SL-5, SL-6, SL-7, SL-8, SL-9, SL-10, SL-11, SL-12

0+00, 1+00, 2+00, 3+00, 4+00

571, 572, 573, 574, 575, 576, 577, 578, 579, 580, 581, 582, 583, 584, 585, 586, 587, 588, 589, 590

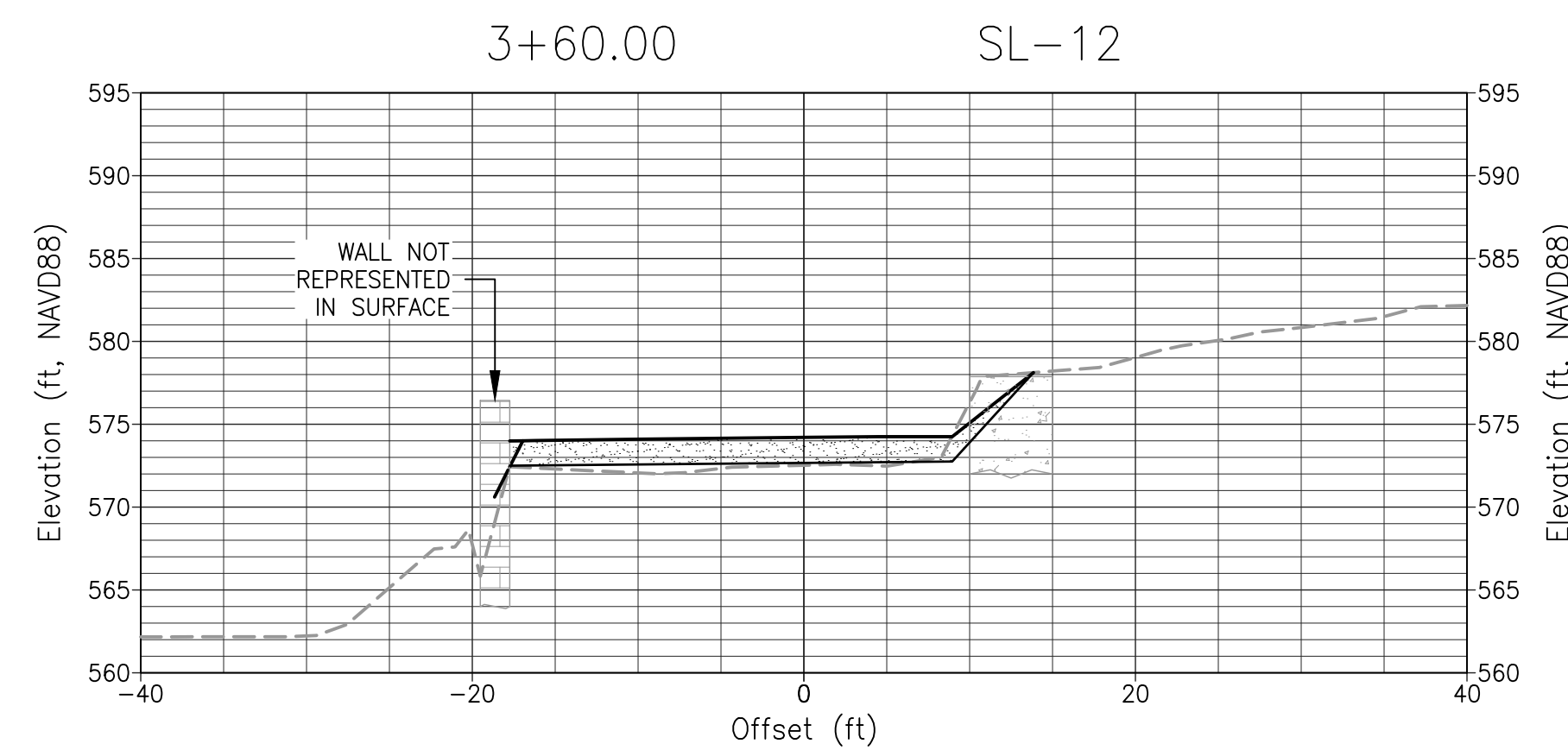
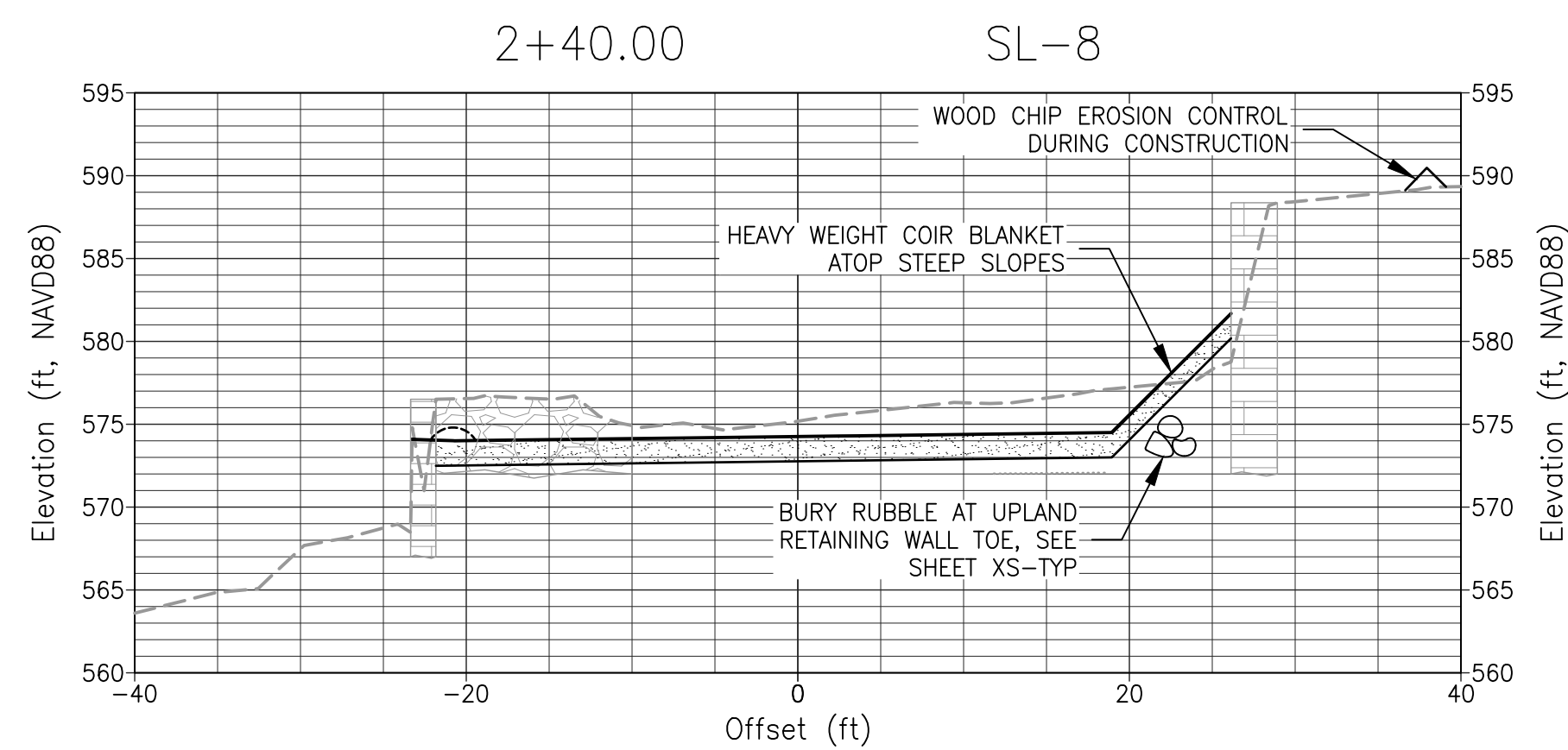
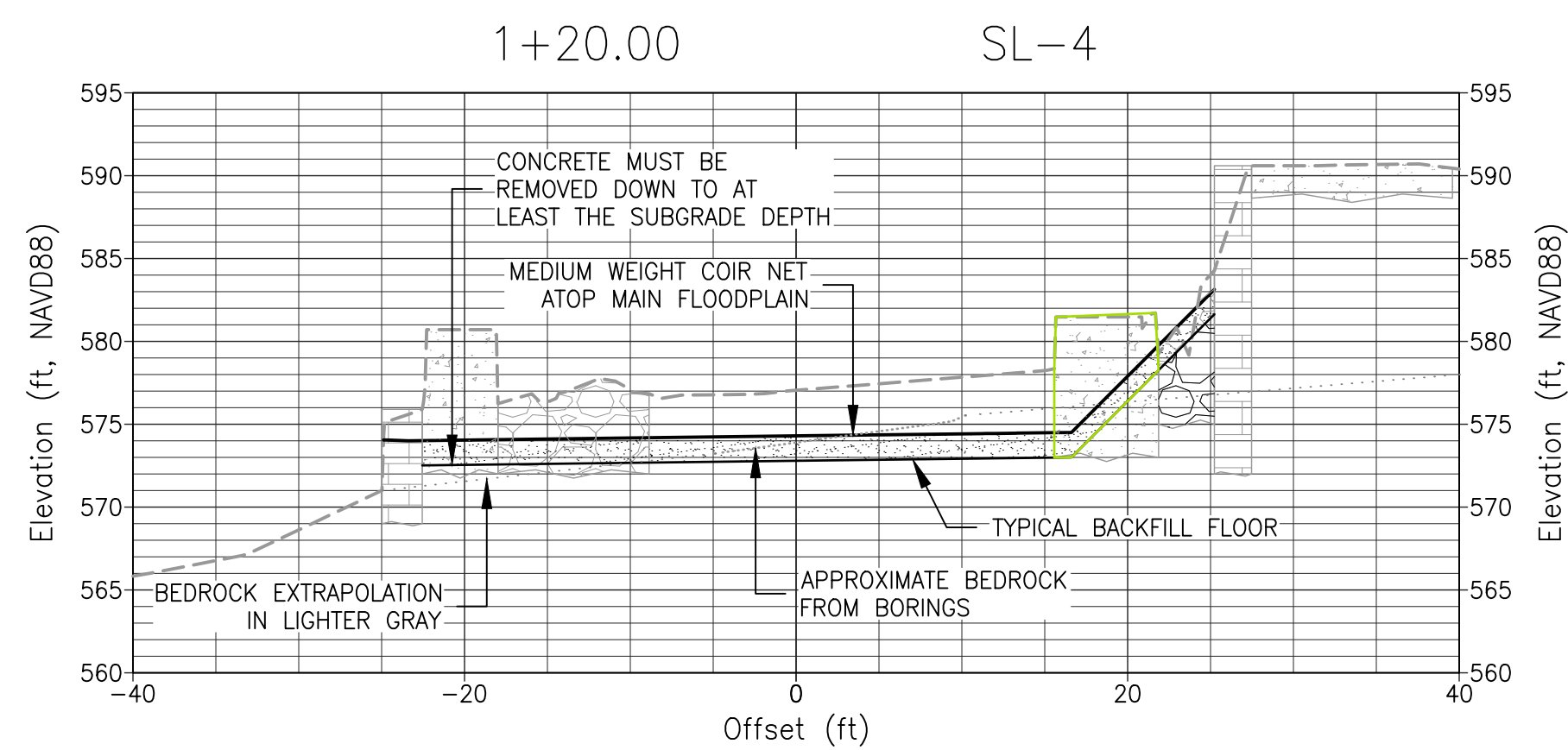
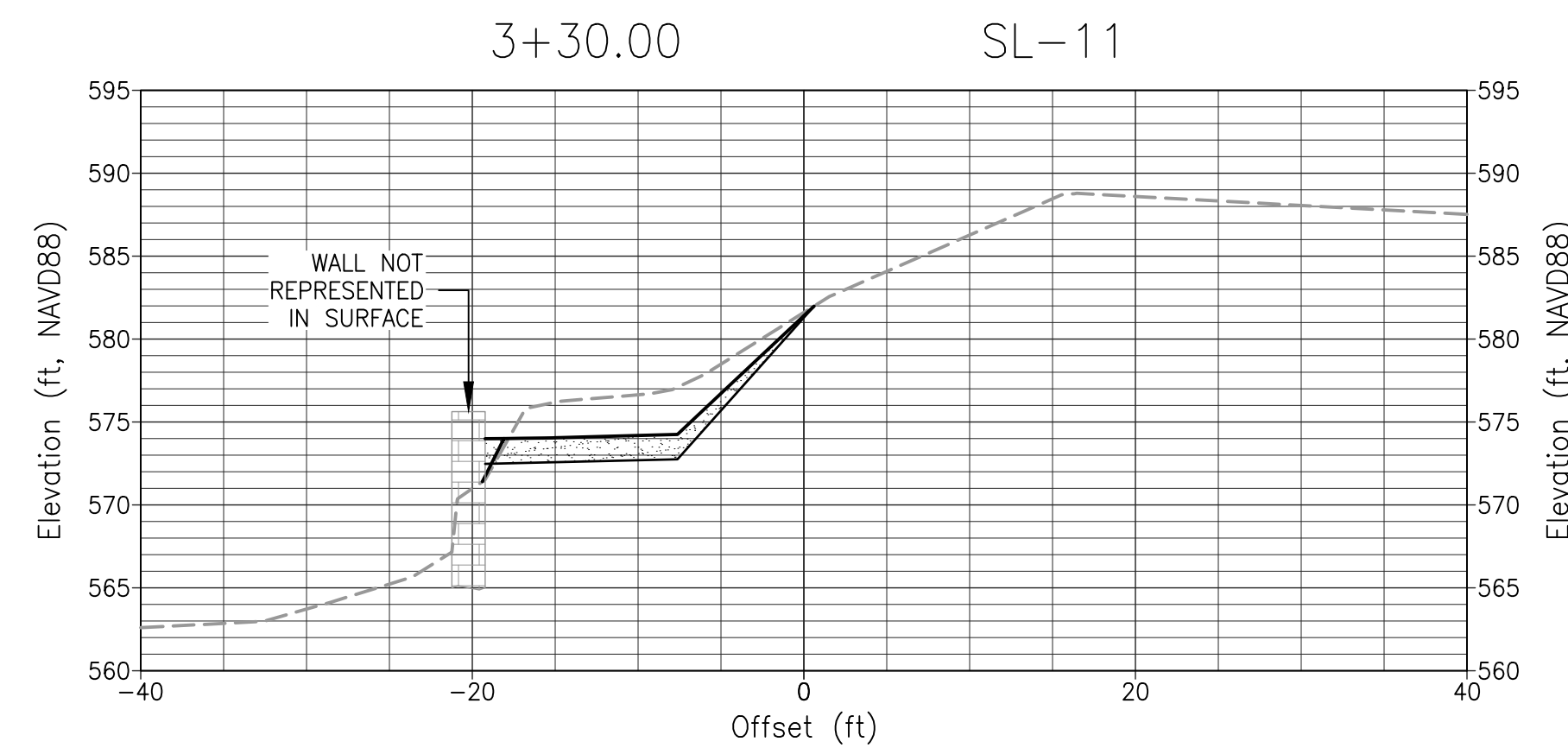
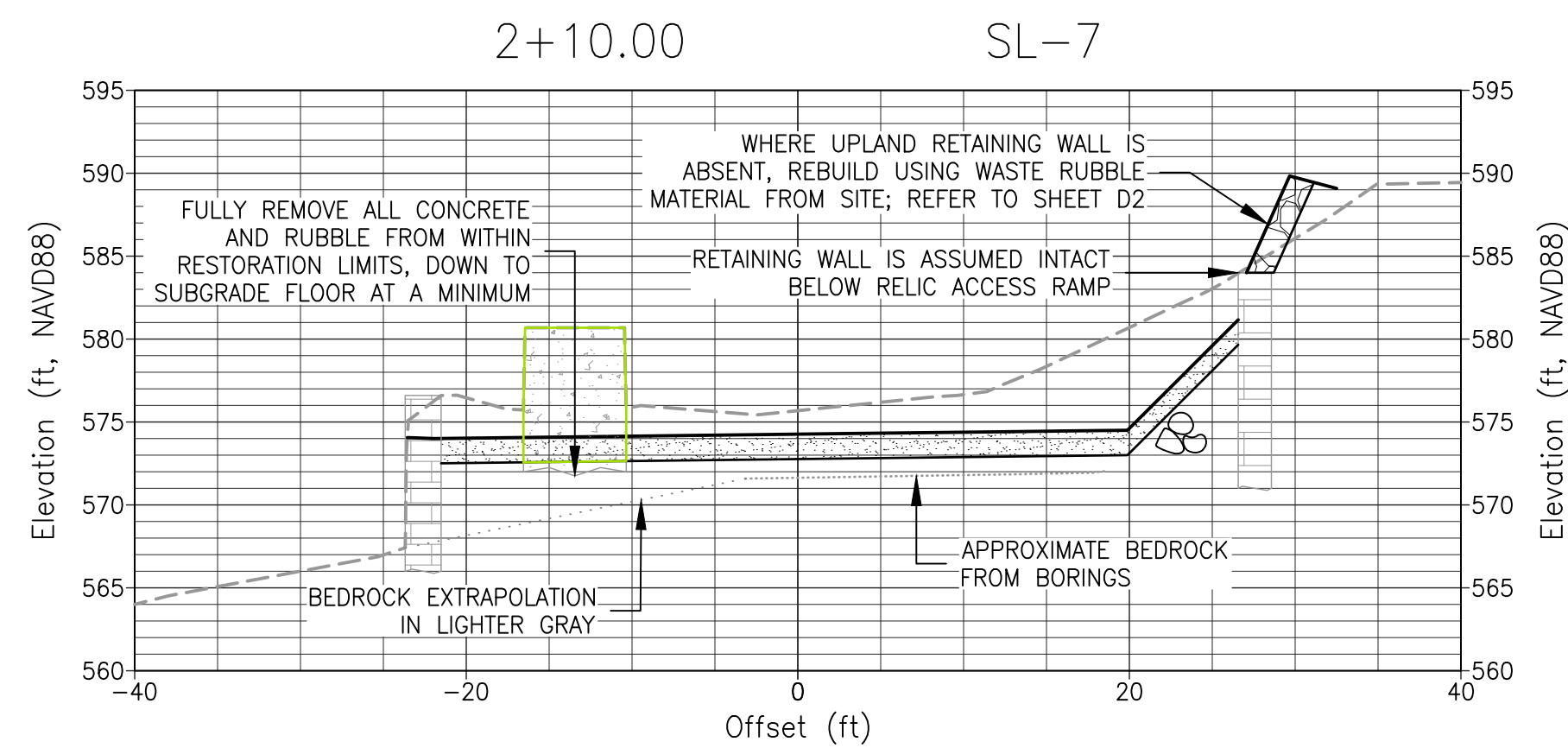
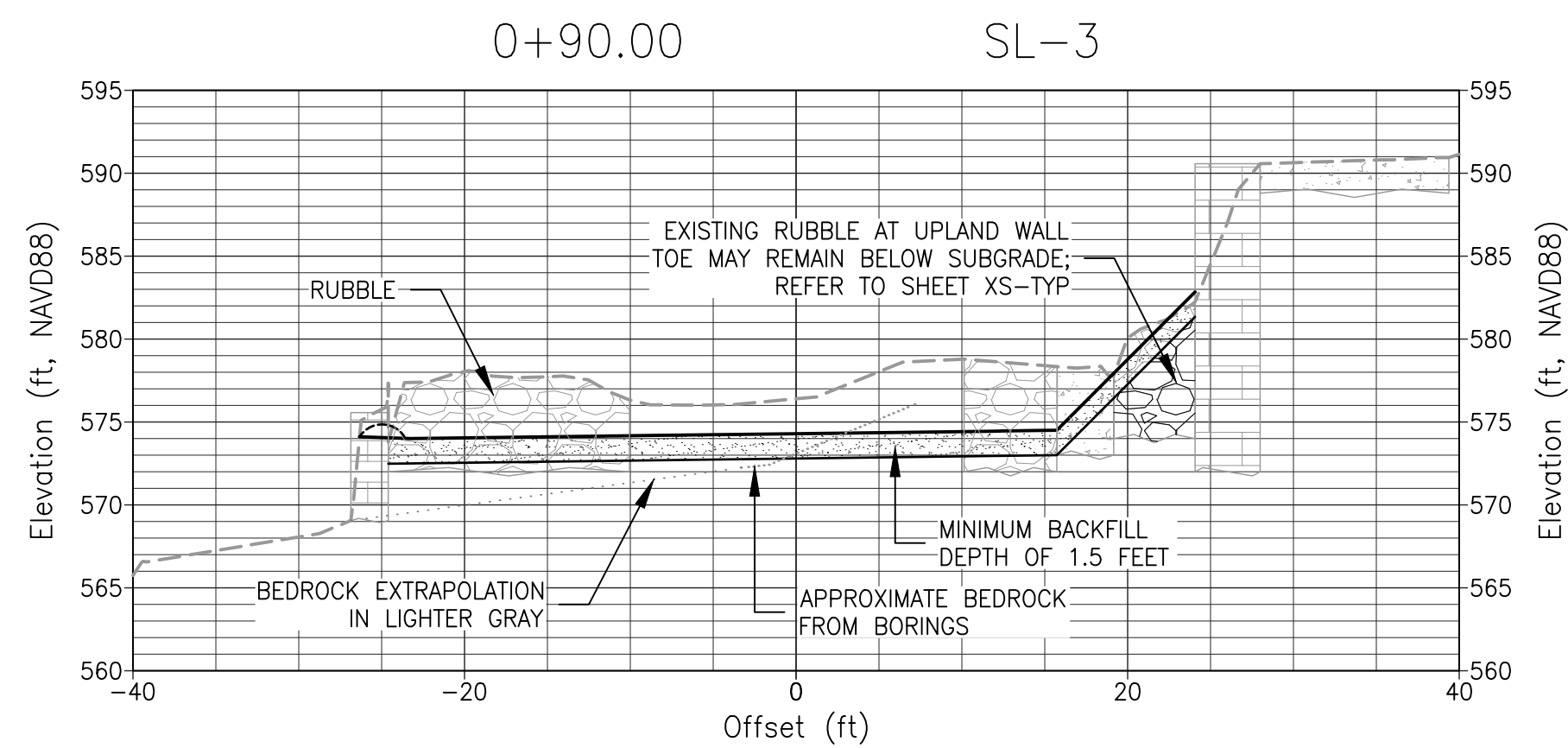
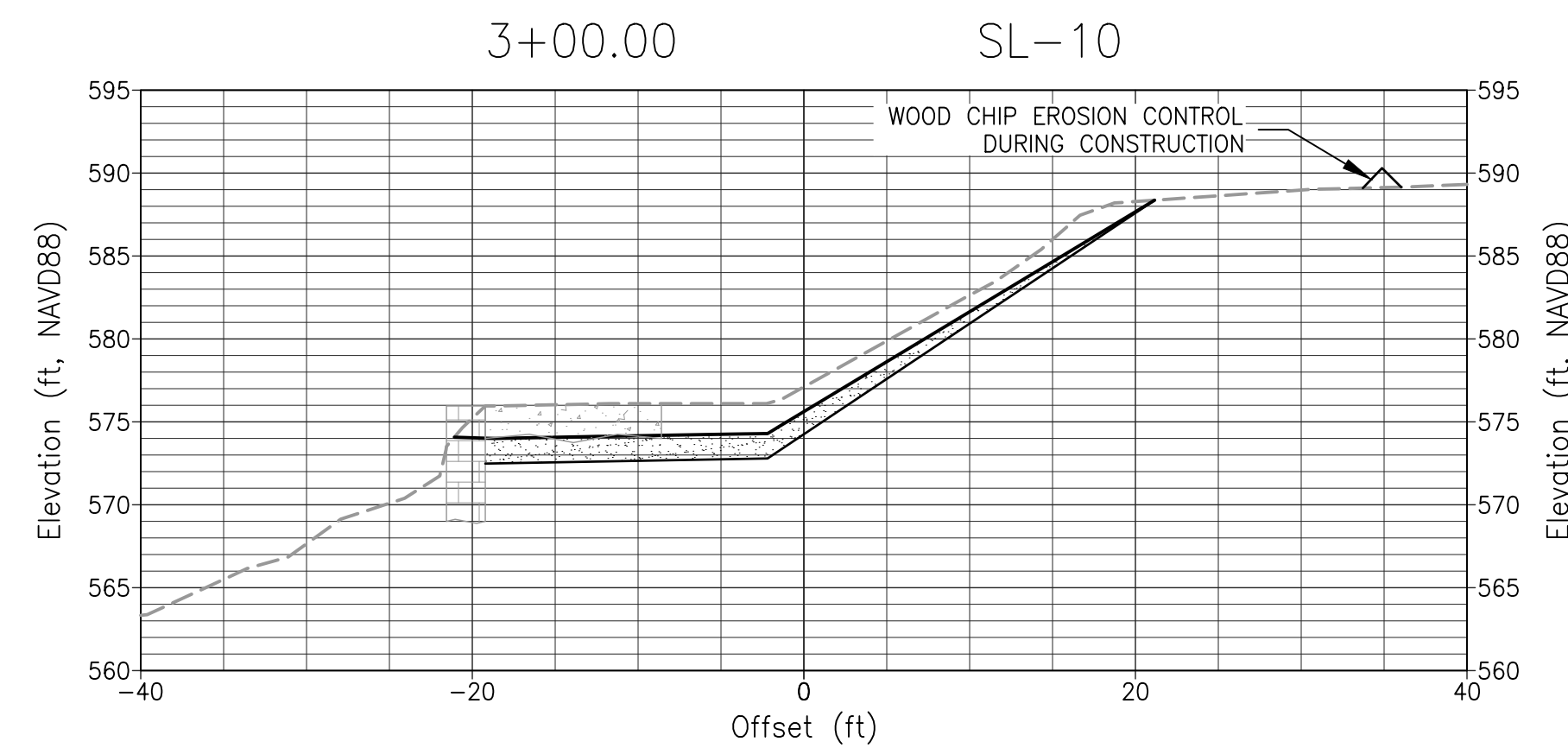
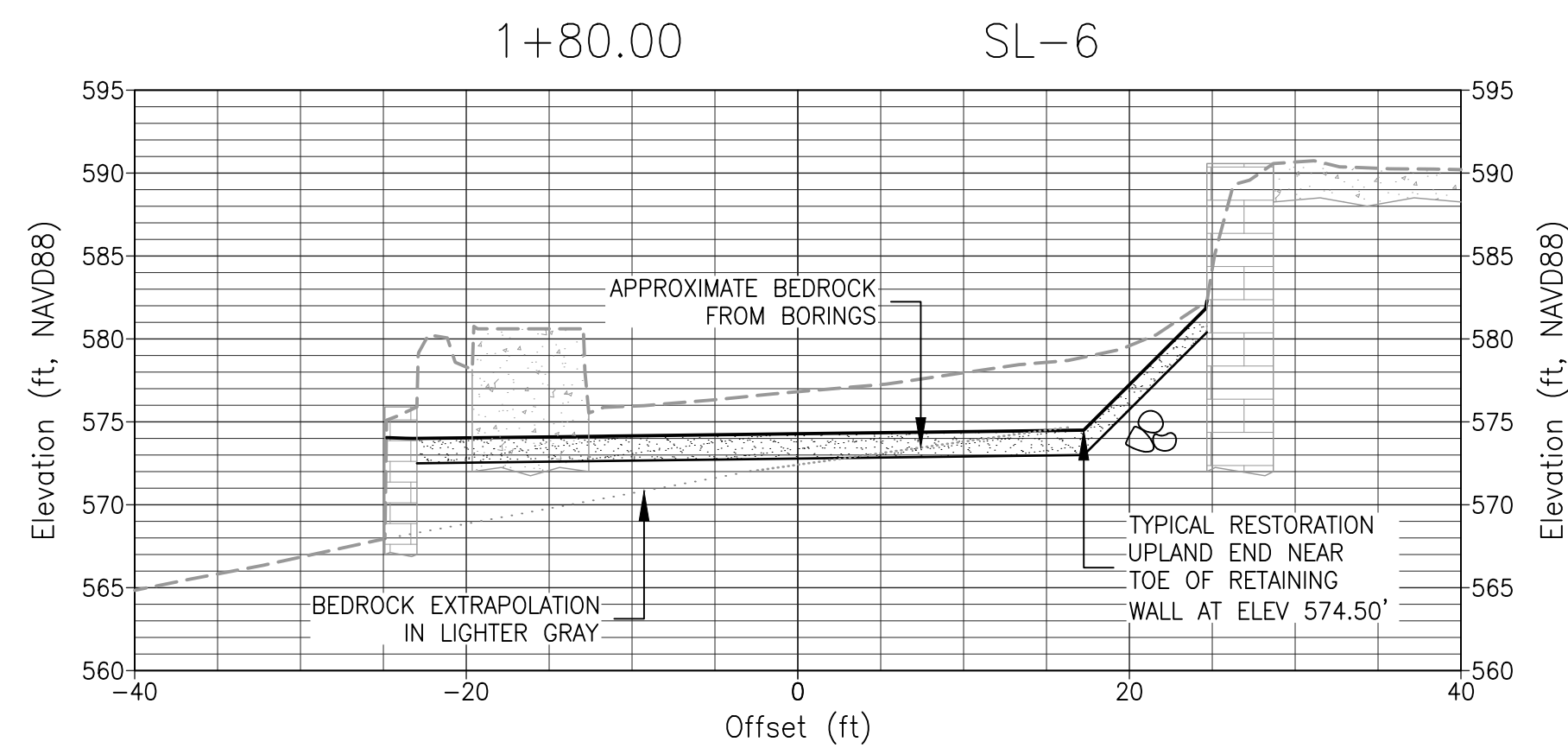
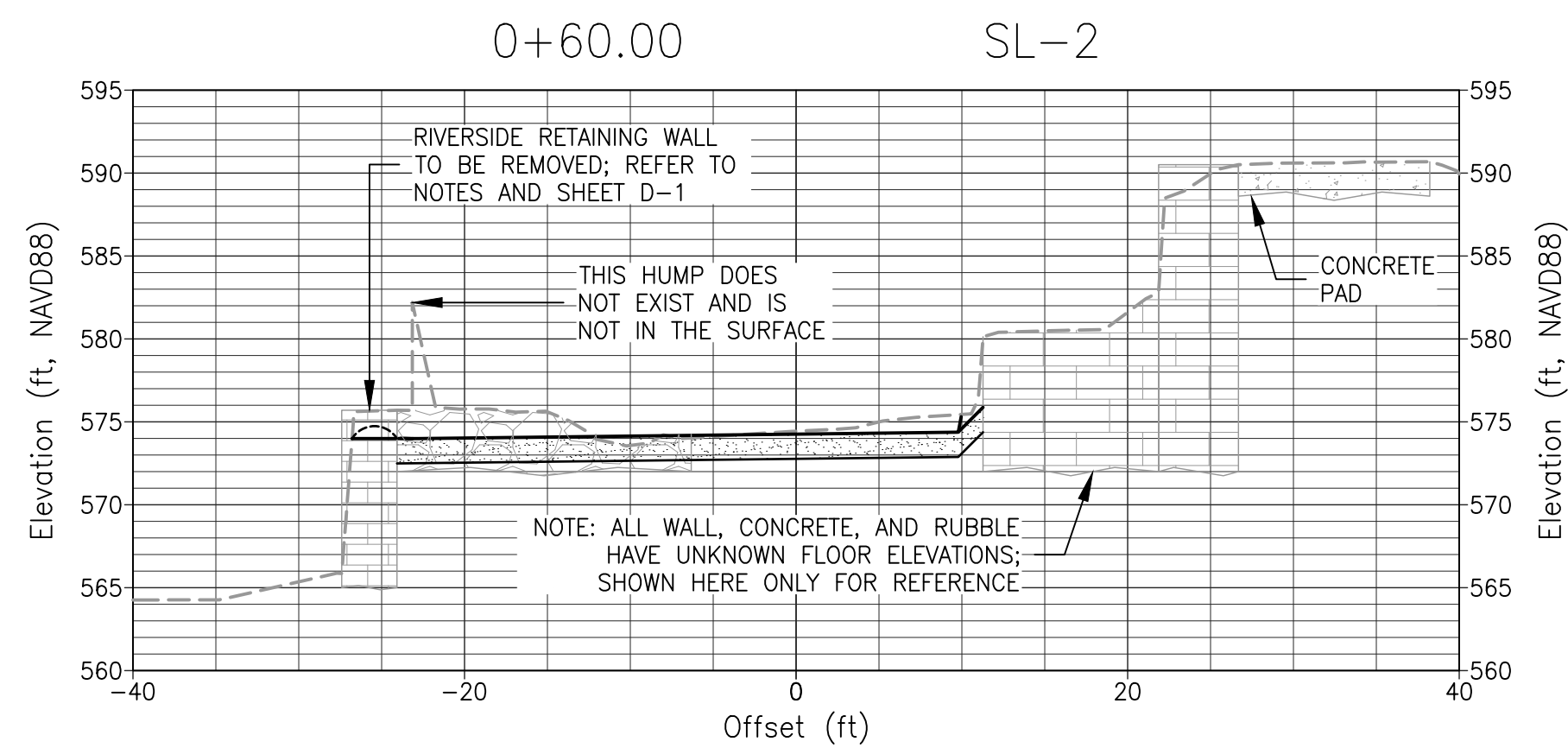
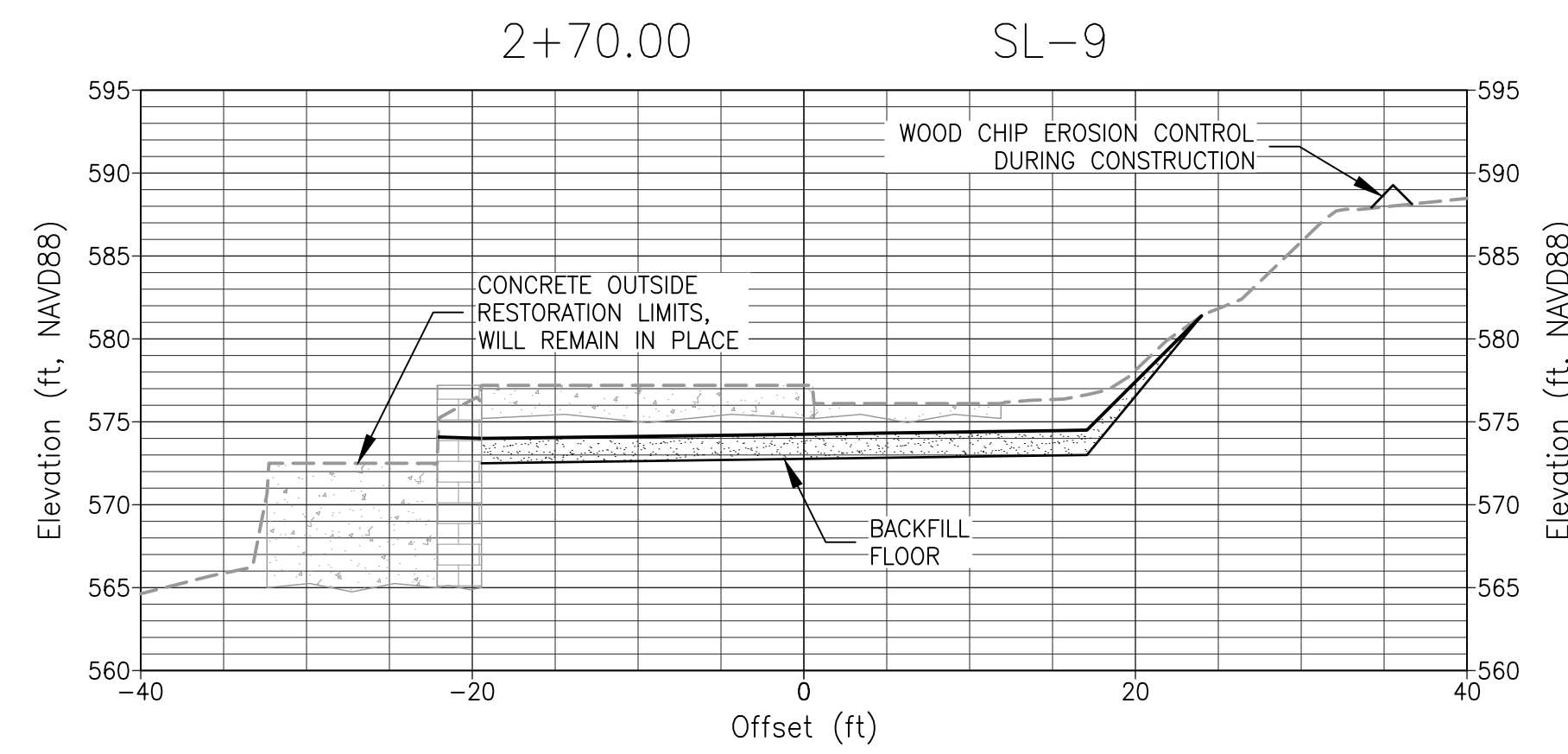
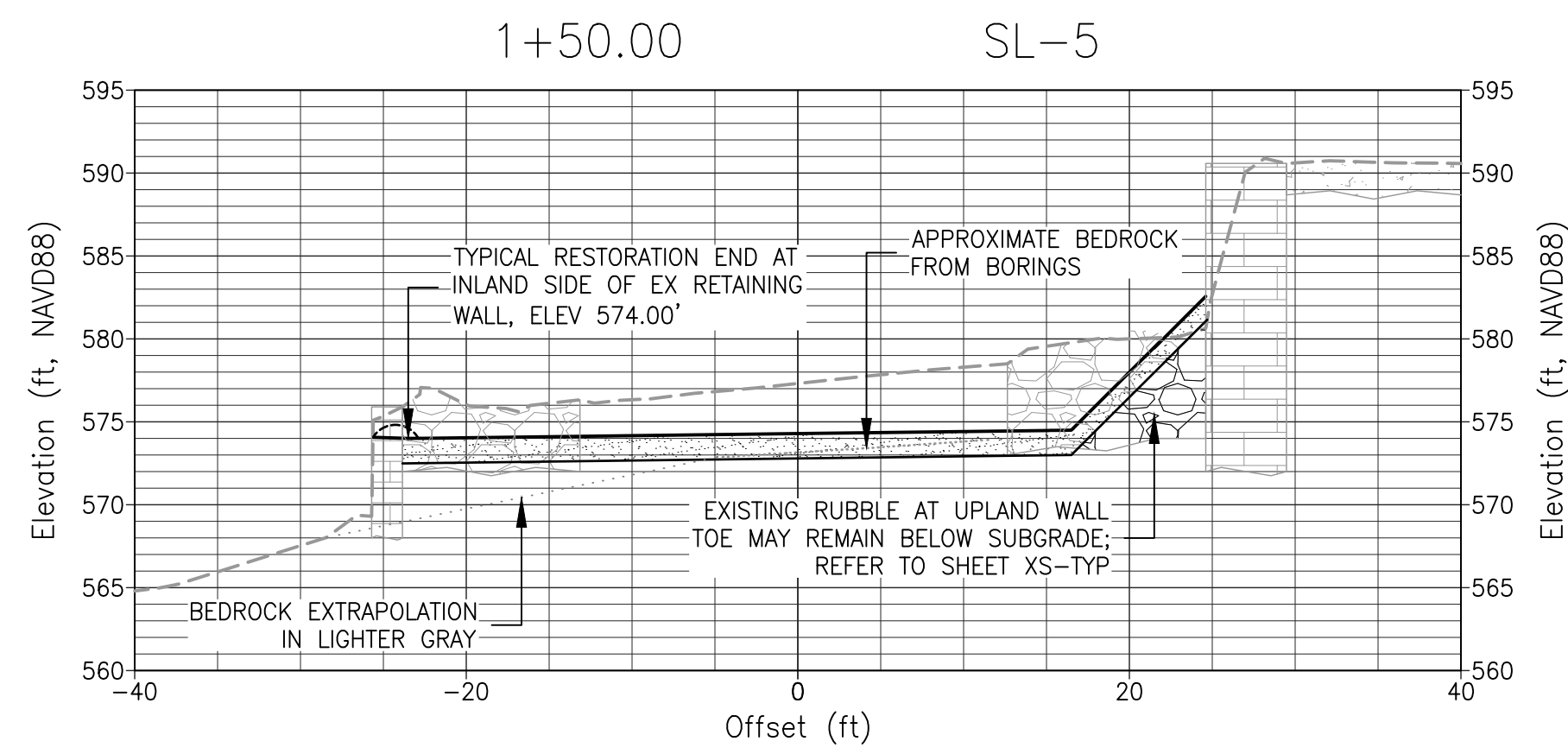
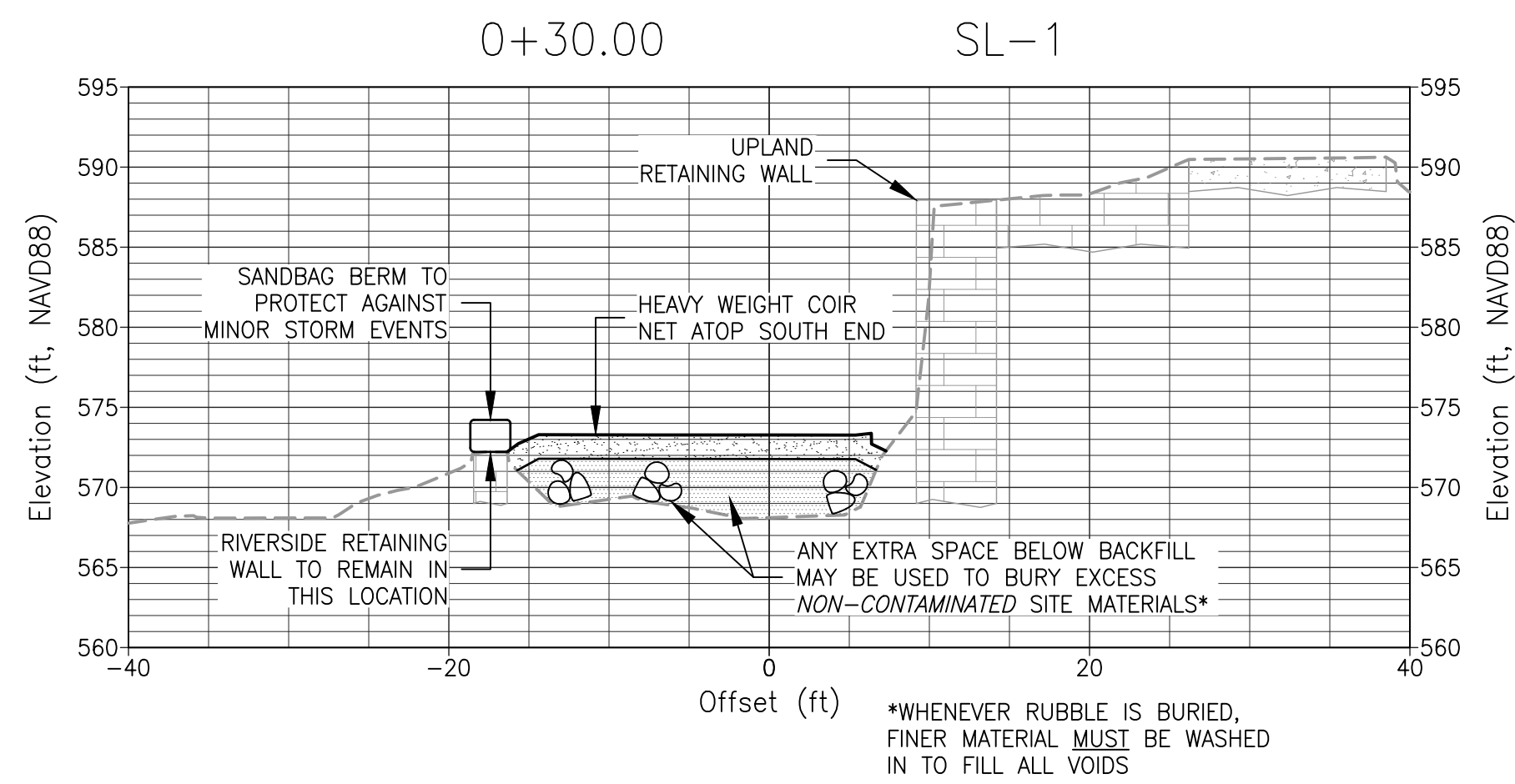

DESIGNED BY: JCB, TPB
 DRAWN BY: JCB
 CHECKED BY: TPB
 DATE: 06 NOV 2025



REVISION #	DATE	NOTES

SITE CROSS SECTIONS
 100% DESIGN SHEETS
 RIPARIAN FLOODPLAIN RESTORATION
 FORMER WOODS WOOLEN MILL, HILLSBOROUGH NH

SHEET TITLE: XSECS
 SHEET SET: 07 OF 11
 PROJECT NAME: RIPARIAN FLOODPLAIN RESTORATION
 PROJECT LOCATION: FORMER WOODS WOOLEN MILL, HILLSBOROUGH NH



SITE ALIGNMENT PROFILE

HORIZONTAL SCALE: 1" = 14'
 2:1 VERTICAL EXAGGERATION
 VERTICAL SCALE: 1" = 7'

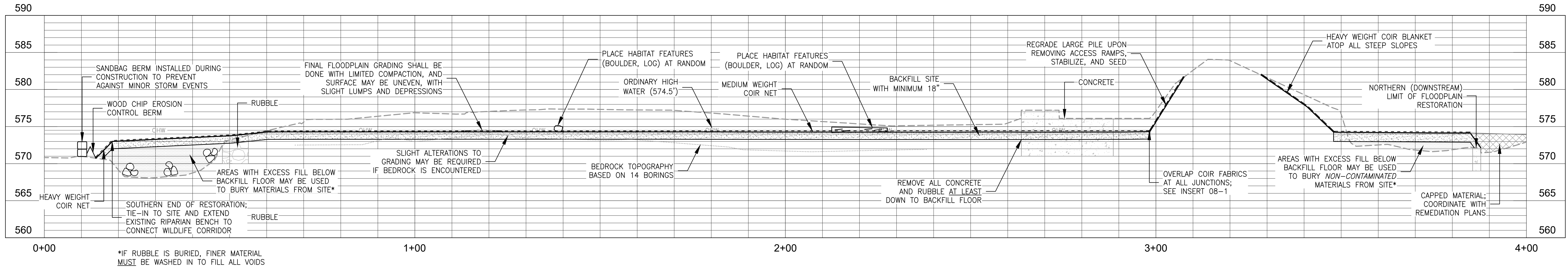
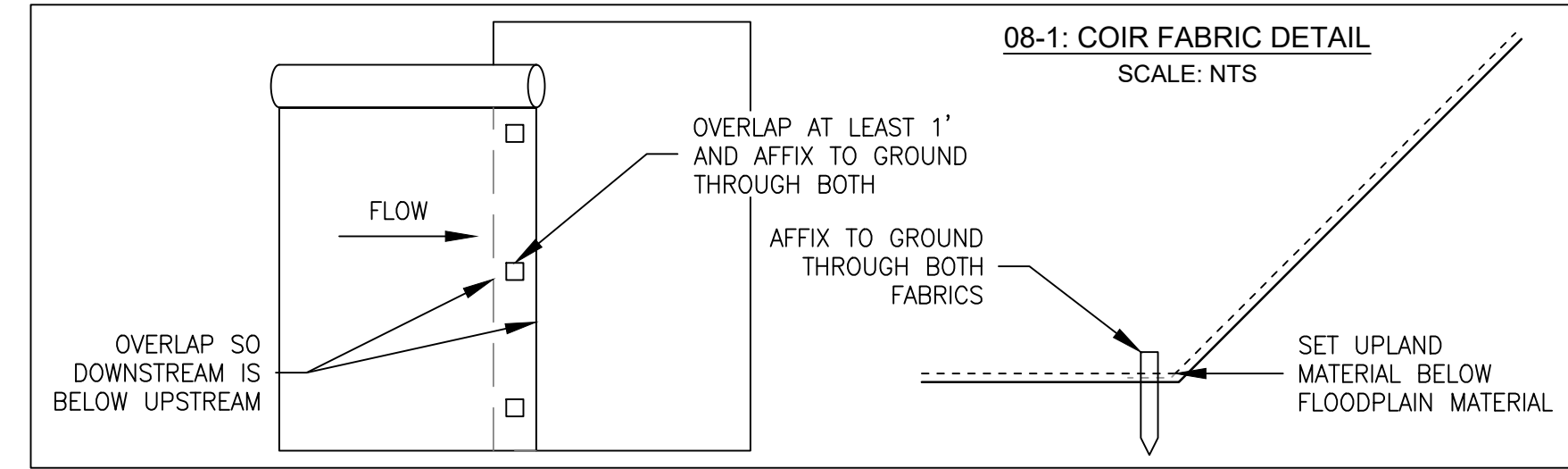

DESIGNED BY:	JCB, TPB
DRAWN BY:	JCB
CHECKED BY:	TPB
DATE:	06 NOV 2025
NOTES:	
REVISION #:	
DATE:	

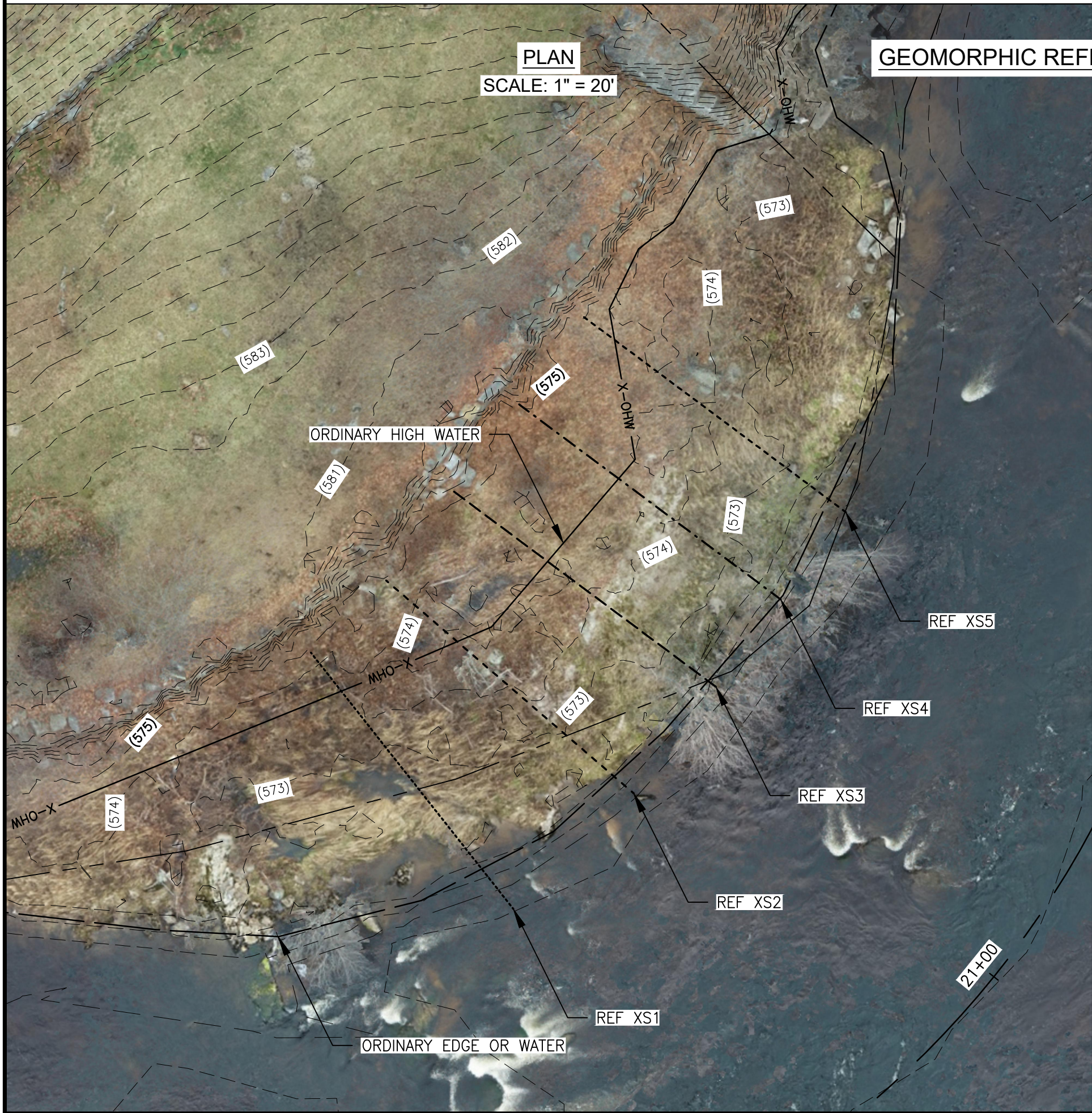

GEOMORPHIC REFERENCE SECTIONS

SECTIONS SCALE: 1" = 3'

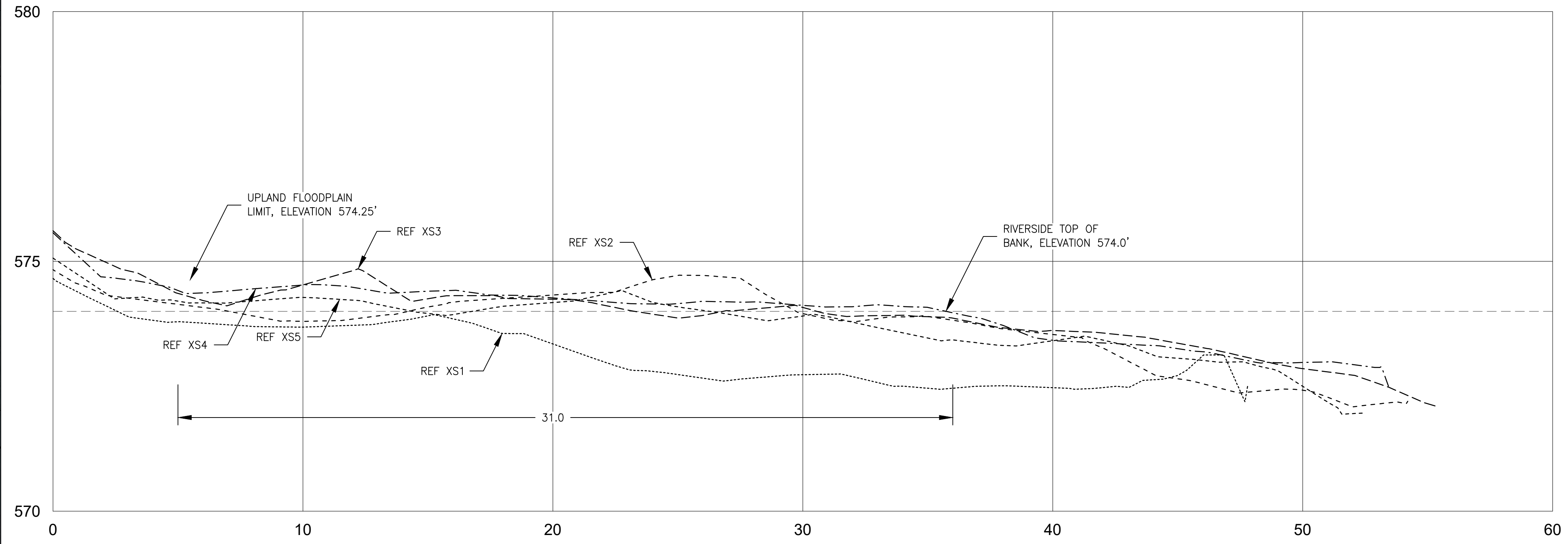

SITE PROFILE & REFERENCE SECTIONS
 100% DESIGN SHEETS
 RIPARIAN FLOODPLAIN RESTORATION
 FORMER WOODS WOOLEN MILL, HILLSBOROUGH NH

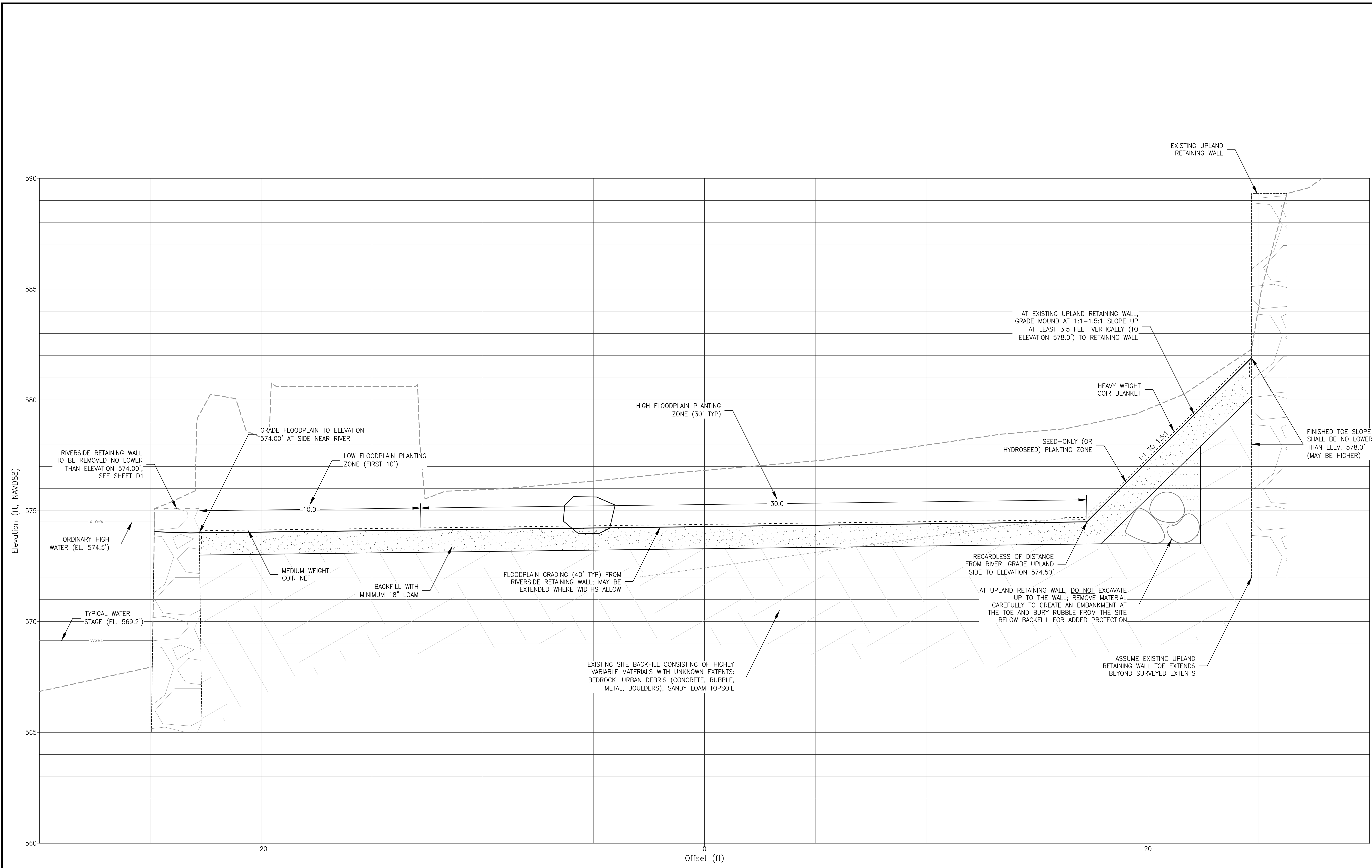

DESIGNED BY:	JCB, TPB
DRAWN BY:	JCB
CHECKED BY:	TPB
DATE:	06 NOV 2025

NOTES:	
REVISION #:	
DATE:	

TYPICAL SITE SECTION
 100% DESIGN SHEETS
 RIPARIAN FLOODPLAIN RESTORATION
 FORMER WOODS WOOLEN MILL, HILLSBOROUGH NH

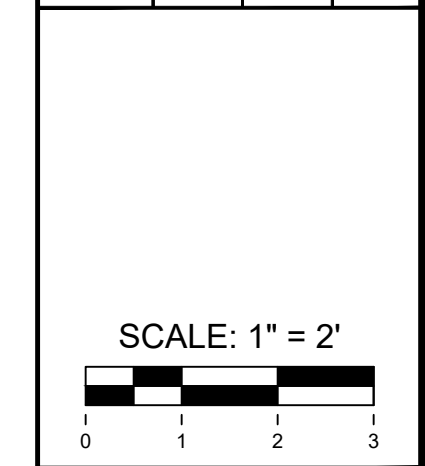

SHEET ID:
XS-TYP
 SHEET NUMBER:
09 OF **11**



LOOKING AT THE SITE RIVERSIDE RETAINING WALL, WITH LINES DEPICTING THE EXISTING TOP (RED) AND PROPOSED TOP (GREEN). THESE LINES ARE APPROXIMATE; THE EXISTING TYPICAL WALL TOP ELEVATION IS 576.2' AND THE PROPOSED FLOODPLAIN ELEVATION AT THE WALL IS 574.0'.

RETAINING WALL WORK SHALL ONLY COMMENCE AFTER RESTORATION AREA HAS BEEN FULLY EXCAVATED TO SUBGRADE FLOOR, THEN BACKFILLED WITH SEVERAL INCHES OF CLEAN TOPSOIL TO ENSURE NO CONTAMINATED SOILS REMAIN EXPOSED. CONSTRUCT A TEMPORARY PATH WITH CRUSHED STONE (SEE INSERT 10-1) TO AVOID COMPACTING BACKFILL WHILE COMPLETING THE RETAINING WALL WORK. THE WALL WILL ACT AS A BERM TO ASSIST WITH EROSION CONTROL AND PROTECT THE WORK AREA SHOULD WATER STAGES RISE. BEGIN BY MARKING THE FINISHED FLOODPLAIN GRADE AT THE WALL OF 574.0'. ASSESS AND MARK WHICH MATERIALS SHALL BE REMOVED AND WHICH SHALL REMAIN (REMAINING MATERIALS DO NOT NEED TO BE MARKED).

PROFILE

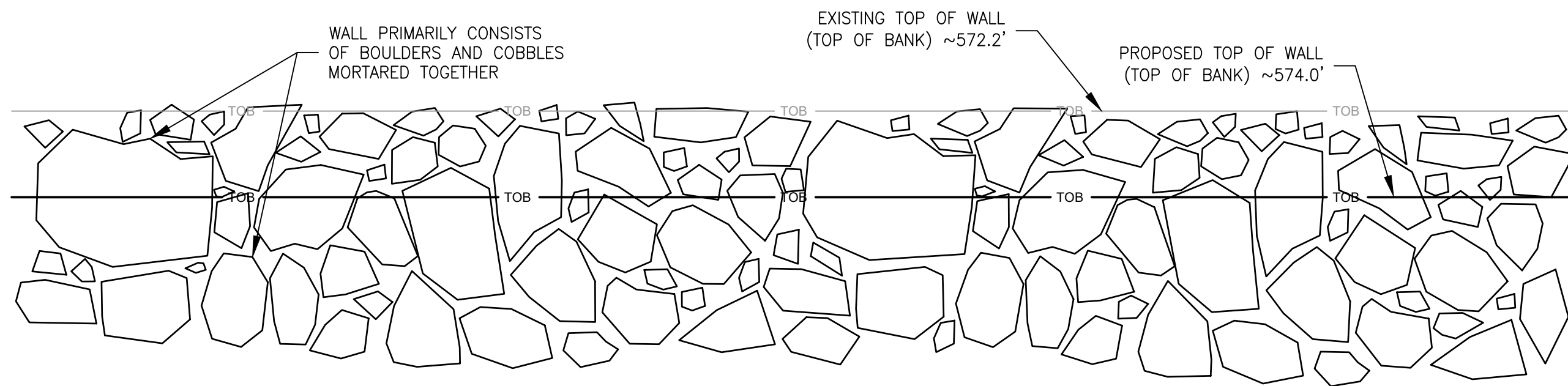

REMOVE ALL MATERIALS CAREFULLY, ENSURING THE INTEGRITY OF THE WALL AND ALL REMAINING MATERIALS. LARGE ROCKS WHICH ARE MOSTLY BELOW ELEVATION 574.0' MAY REMAIN IN PLACE, SO LONG AS THEIR PROTRUSION IS LESS THAN 1.5'. LARGE ROCKS WHICH ARE MOSTLY ABOVE ELEVATION 574.0' MAY BE REMOVED, THOUGH THEIR VOIDS MUST BE FILLED REUSING STOCKPILED MATERIALS. LOCATIONS WHERE THE WALL CONSISTS OF CONCRETE SHALL BE REMOVED DOWN TO ELEVATION 574.0' TO THE BEST EXTENT POSSIBLE THOUGH IS NOT REQUIRED TO BE CUT FLAT.

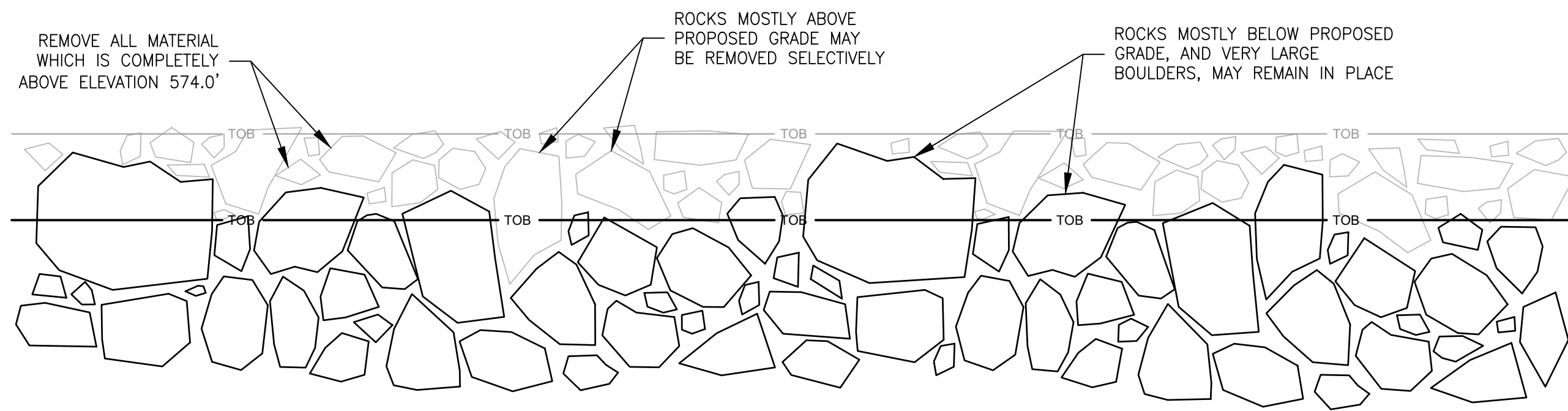

PLACE GROUT BETWEEN ALL GAPS OF EXPOSED ROCKS ATOP THE WALL. USE SMALLER ONES TO FILL LARGE GAPS. FILL ANY VOIDS LEFT WHEN REMOVING LARGER ROCKS BELOW ELEVATION 574.0'. PLACE GROUT BETWEEN ALL ROCKS USED TO FILL GAPS AND VOIDS. THE RESULTING WALL PROFILE WILL BE JAGGED AND IRREGULAR, WITH MANY ROCKS ABOVE ELEVATION 574.0' THOUGH NO GAP BELOW IT. THERE SHOULD BE GAPS IN THE PROFILE AT ELEVATION 574.0' WHERE UPLAND RUNOFF OR FLOOD FLOWS MAY ESCAPE FOR AT LEAST ONE THIRD OF THE WALL LENGTH, AND NO TWO GAPS SHALL BE MORE THAN 10 FEET APART.

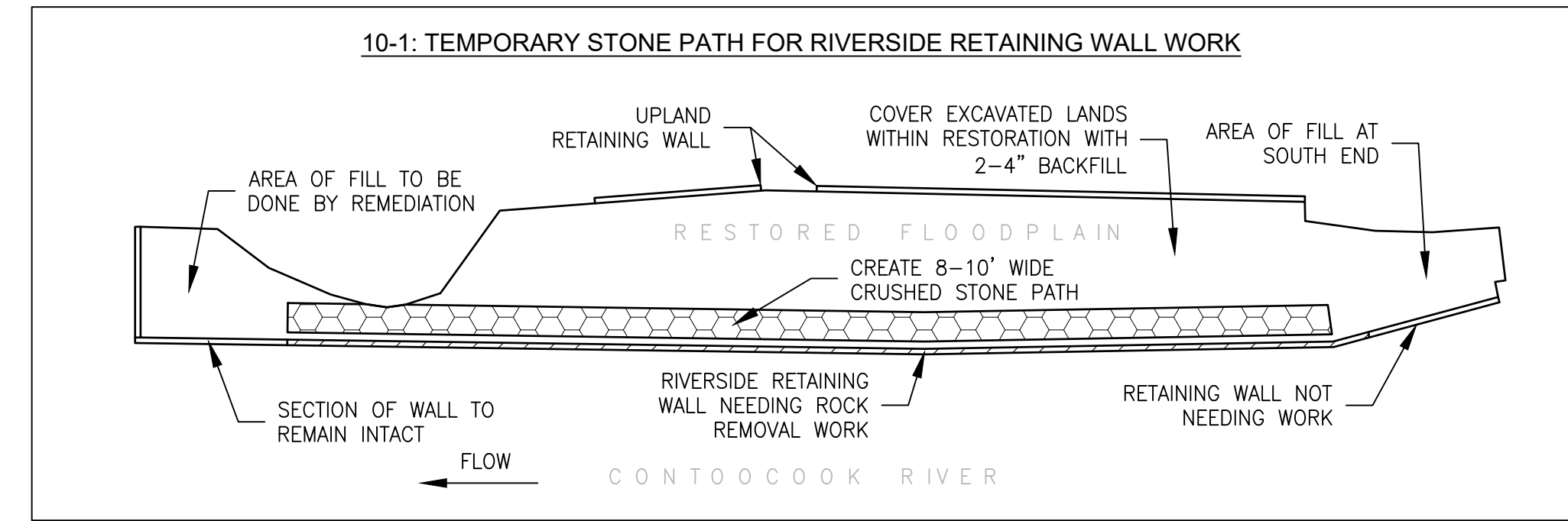
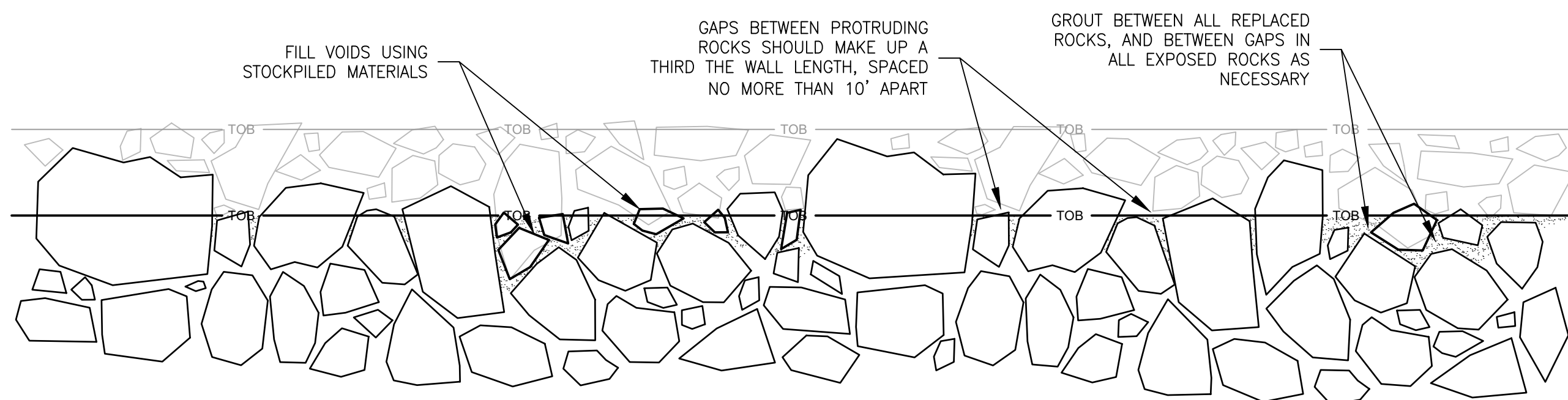

SECTION

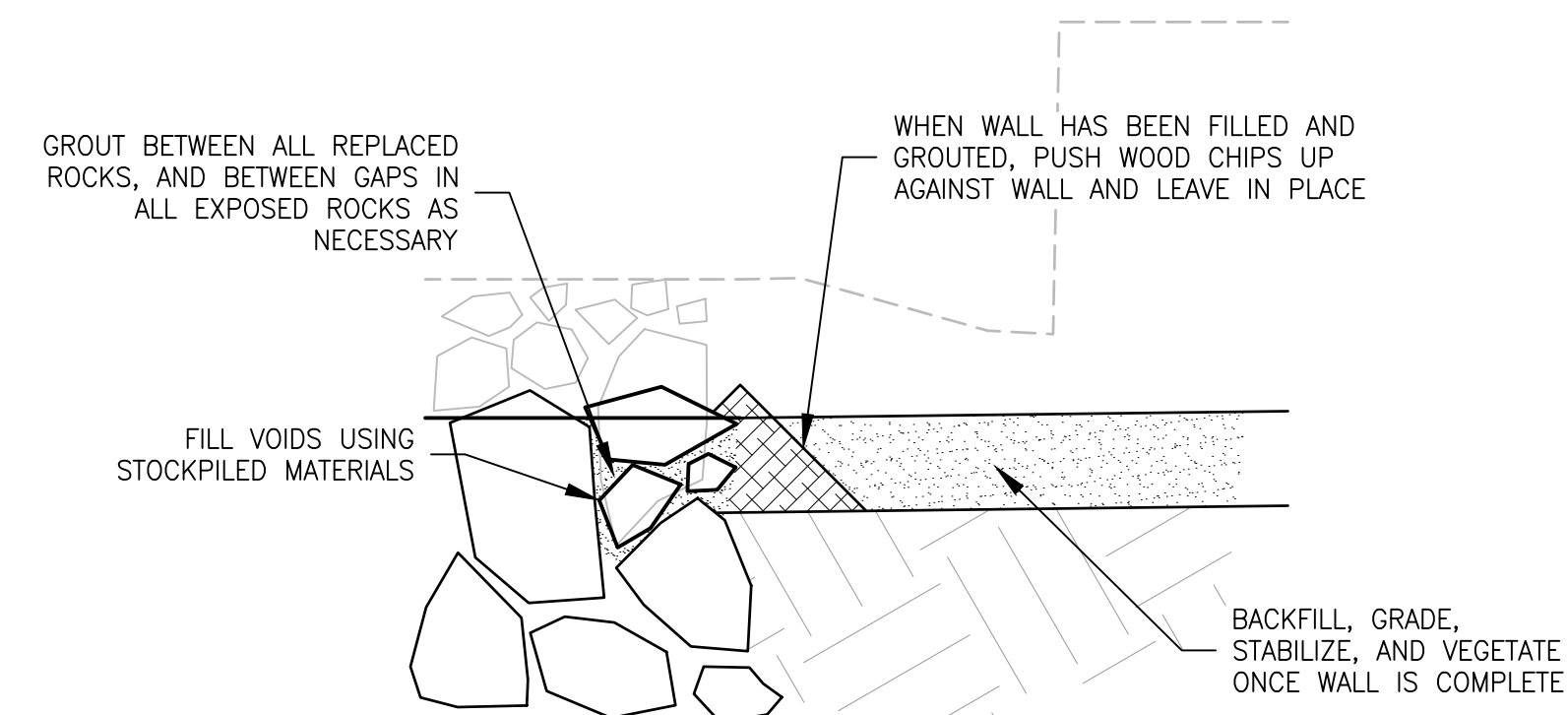
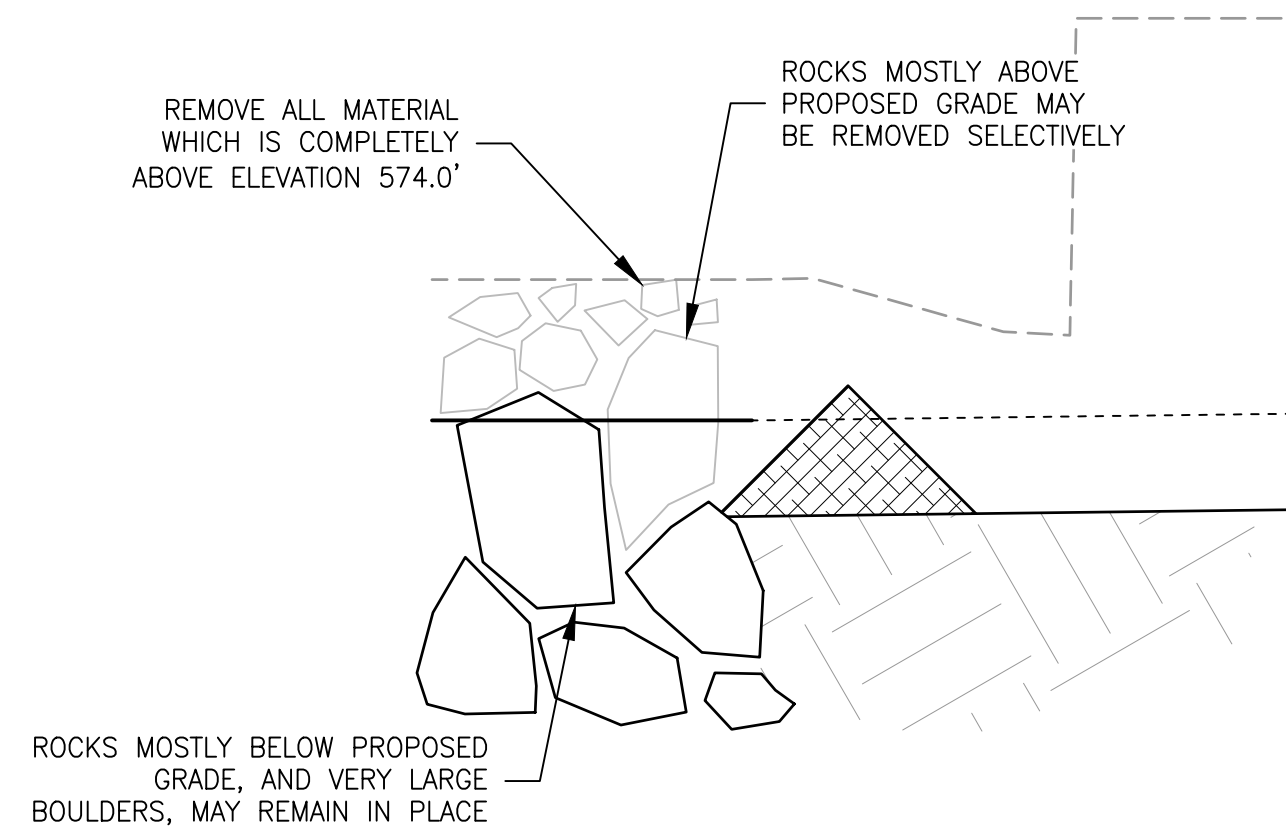
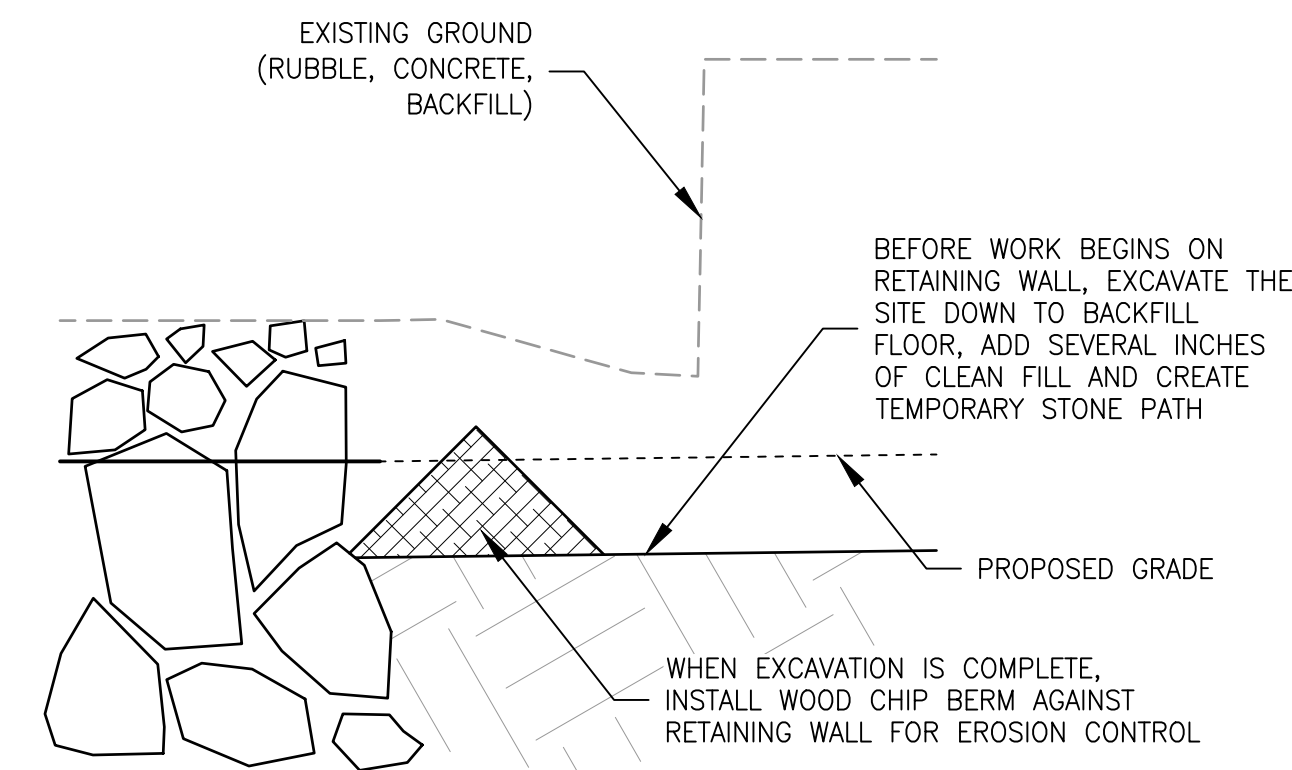

DESIGNED BY: JCB, TPB
 DRAWN BY: JCB
 CHECKED BY: TPB
 DATE: 06 NOV 2025



REVISION #	DATE	NOTES

SHEET TITLE: **RIVERSIDE RETAINING WALL DETAIL**
 SHEET SET: **100% DESIGN SHEETS**
 PROJECT NAME: **RIPARIAN FLOODPLAIN RESTORATION**
 PROJECT LOCATION: **FORMER WOODS WOOLEN MILL, HILLSBOROUGH NH**

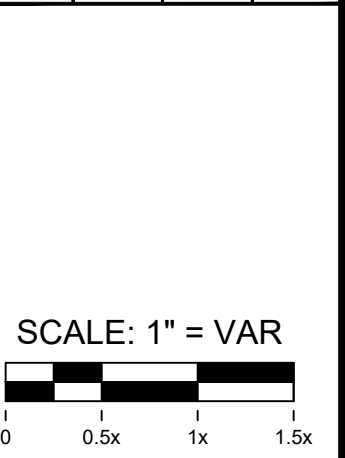

SHEET ID: **D-1**
 SHEET NUMBER: **10 OF 11**

D-2a: UPLAND RETAINING WALL GAP

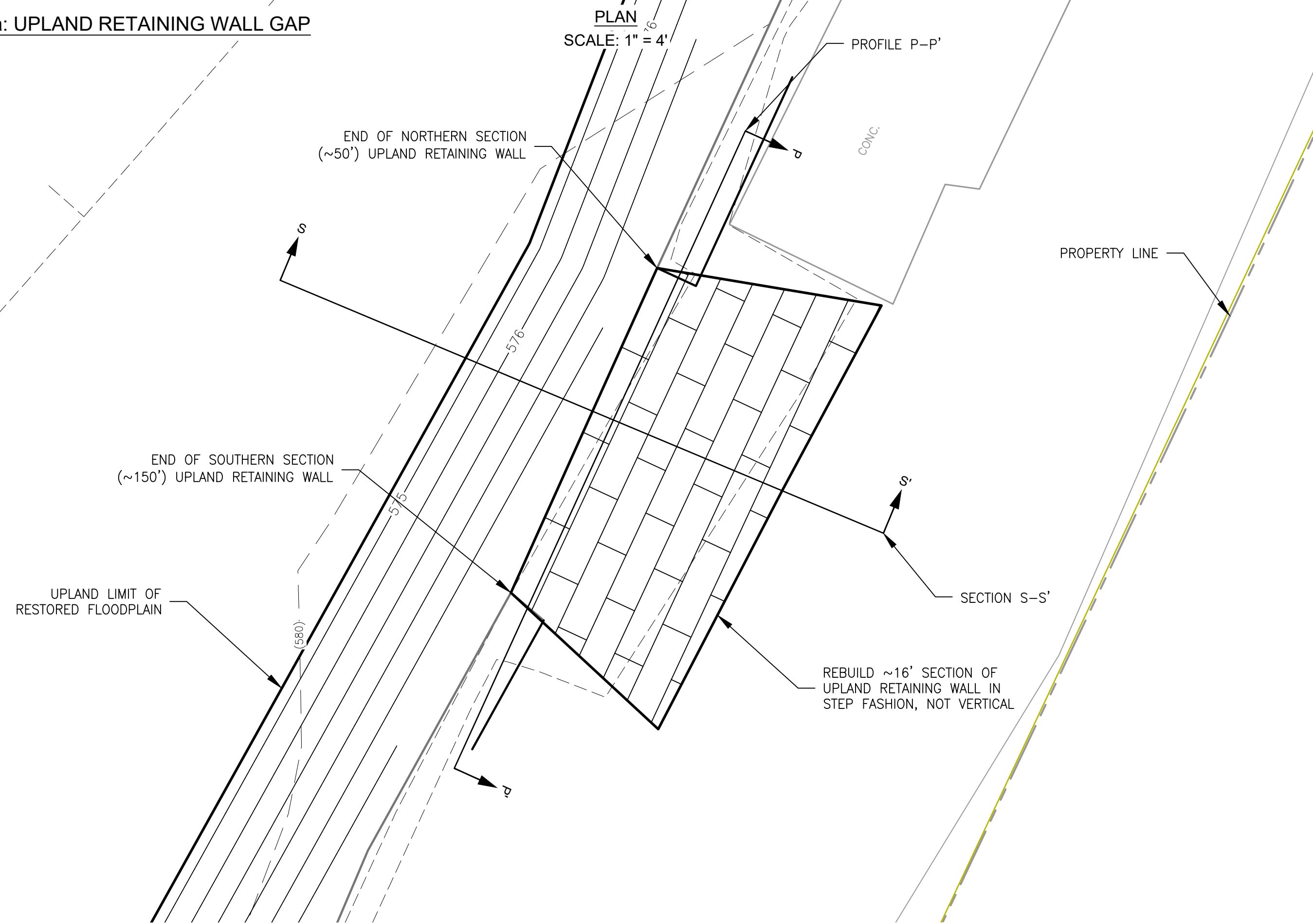

UPLAND RETAINING WALL RECONSTRUCTION AND REINFORCEMENT NOTES:

1. THE UPLAND RETAINING WALL IS NEED OF BOTH RECONSTRUCTION AND REINFORCEMENT:
 - 1.1. RECONSTRUCTION ALONG A ~16 FOOT SECTION WHICH WAS REMOVED DURING PREVIOUS REMEDIATION EFFORTS AND BACKFILLED WITH EARTH USED AS AN ACCESS RAMP.
 - 1.4. REINFORCEMENT ALONG THE ENTIRE LENGTH (ABOUT 200 FEET TOTAL) OF THE EXISTING EXPOSED WALL.
- RECONSTRUCTION**
2. IT IS ASSUMED THAT BELOW THE EARTHEN RAMP THE EXISTING WALL REMAINS AND IS IN SIMILAR CONDITION TO THE SURROUNDING EXPOSED WALL.
 3. THE LARGE ROCK MATERIAL REMOVED FROM THIS SECTION OF WALL WAS PLACED IN PILES AROUND THE SITE ALONG WITH OTHER LARGE ROCK RUBBLE.
 4. LARGE ROCK FOUND ONSITE SHALL BE REUSED TO RECONSTRUCT THIS SECTION OF WALL. MATERIAL SHOULD BE LARGER THAN 400 POUNDS WITH A MIDDLE DIMENSION 1 FOOT OR LARGER.
 5. USE LARGE MATERIAL WHICH IS MORE RECTANGULAR, CONSISTING OF ROCK NOT CONCRETE.
 6. RECONSTRUCT THE REMOVED SECTION OF WALL IN A STEP FASHION, NOT A VERTICAL WALL, MIMICKING THE EXISTING ~1.5:1 SLOPE OF THE EARTH ACCESS RAMP.
 7. BEGIN BY EXCAVATING EXISTING EARTH RAMP TO FIND ASSUMED BURIED EXISTING WALL. LARGE DEVIATIONS FROM ASSUMED ROCK WALL (PRESENCE, TOP ELEVATION) MAY REQUIRE ALTERATION TO THE DESIGN IN THE FIELD.
 8. BEGIN RECONSTRUCTION ON TOP OF THE EXISTING, BURIED WALL WHERE FOUND.
 9. DO NOT EXCAVATE BEHIND EXISTING RETAINING WALL, ONLY BEHIND PROPOSED WALL AS NECESSARY TO INSTALL NEW ROCKS.
 10. STACK LARGE ROCKS ONE ROW AT A TIME, FILLING GAPS LARGER THAN 4 INCHES WITH SMALLER MATERIAL.
 11. BACKFILL BEHIND AND BELOW EACH ROW WITH 3/4" CRUSHED STONE.
 - 11.1. THIS WILL REQUIRE APPROXIMATELY 10 YARDS OF MATERIAL
 12. USE MORTAR (OR SIMILAR) MATERIAL BETWEEN ROWS OF ROCK AND IN GAPS LARGER THAN 4 INCHES.
 13. GAPS SMALLER THAN 4 INCHES MAY REMAIN TO ALLOW SEEP, PREVENTING AGAINST FROST AND ICE SHOVING.

REINFORCEMENT

14. THE EXISTING UPLAND RETAINING WALL REQUIRES REINFORCING ALONG THE ENTIRE LENGTH, FOR ANY WALL LEFT EXPOSED.
15. THIS SHALL BE DONE BY FILLING GAPS USING ROCK FOUND ONSITE AND MORTAR TO LOCK THEM IN PLACE.
16. MORTAR SHALL BE PLACED IN ALL REMAINING GAPS LARGER THAN 4 INCHES. SOME GAPS SMALLER THAN 4 INCHES MAY REMAIN OPEN TO ALLOW GROUNDWATER TO SEEP OUT.
17. SOME RELIC INFRASTRUCTURE REMAINS EMBEDDED IN THE WALL. PROTRUDING MATERIALS (PIPES) SHALL BE CUT FLUSH WITH THE WALL.
18. DO NOT PLUG EXISTING INFRASTRUCTURE AND DO NOT RIP MATERIALS OUT.

UPLAND WALL TOE REINFORCEMENT SLOPE

19. DO NOT FULLY EXCAVATE NEAR THE TOE OF THE UPLAND RETAINING WALL. MAXIMUM EXCAVATION SHOULD ONLY BE TO ELEVATION 576.5'.
20. CONSTRUCT THE PROTECTION SLOPE TO ELEVATION 578.0'. REFER TO SHEET XS-TYP FOR MORE DETAILS.

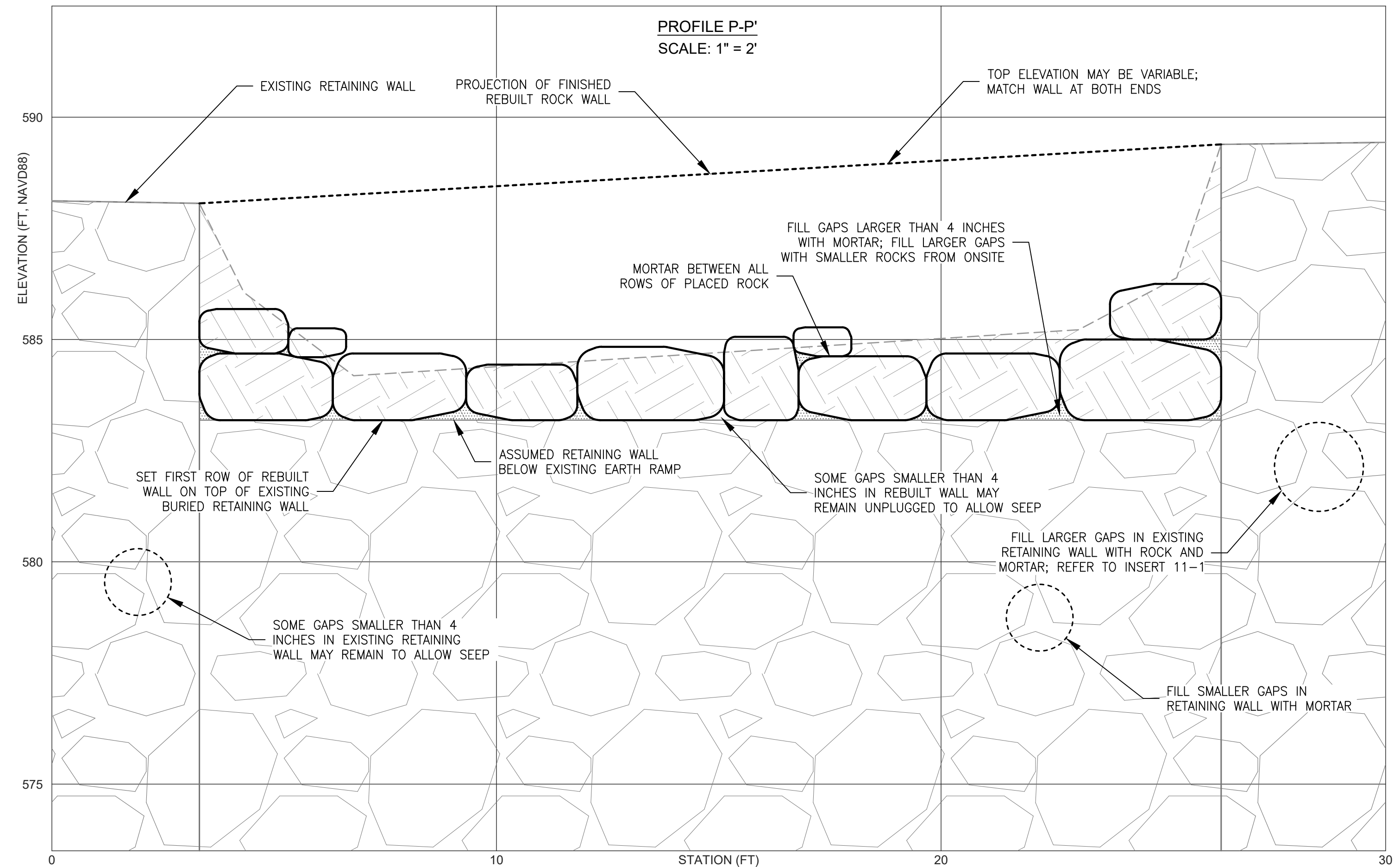
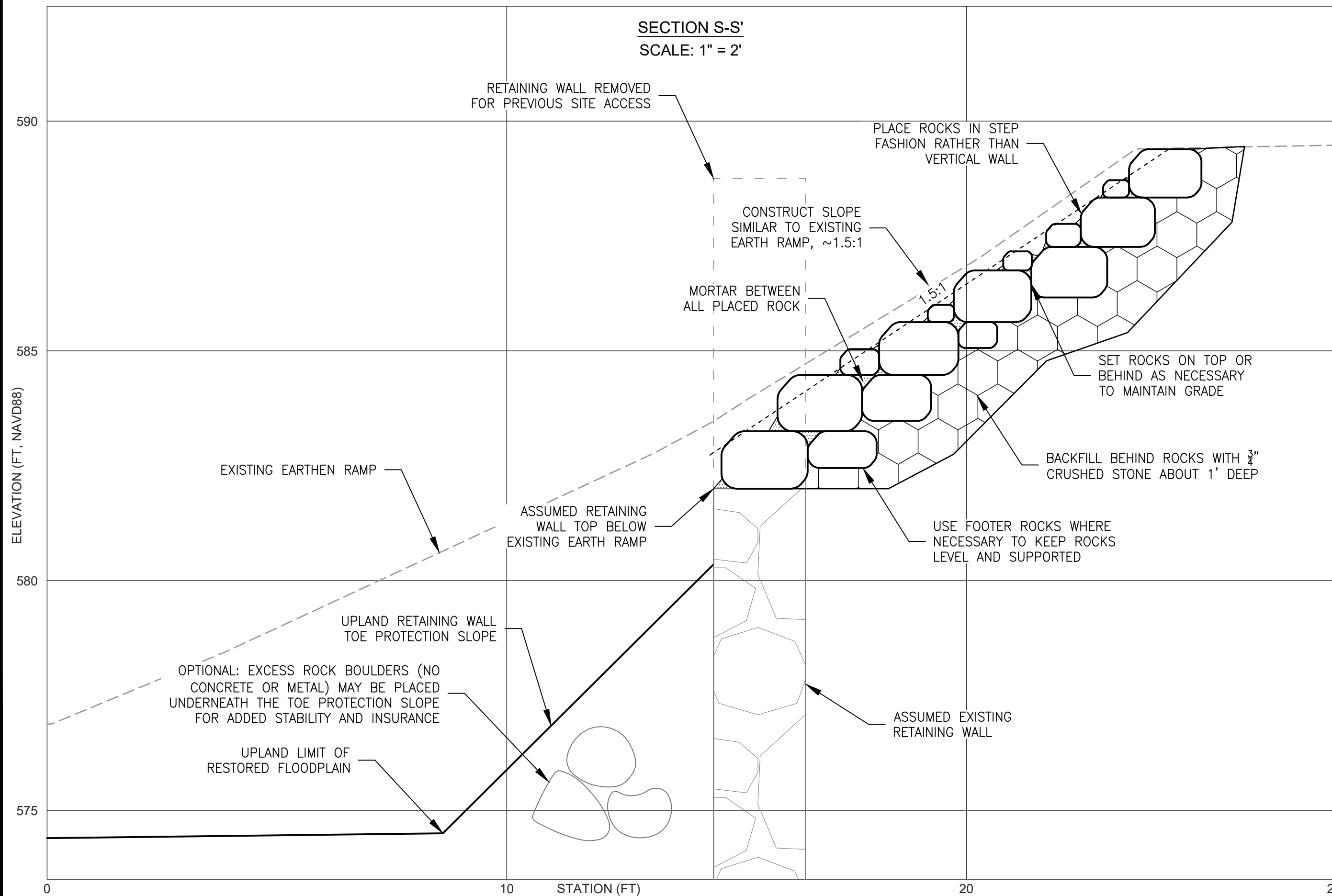
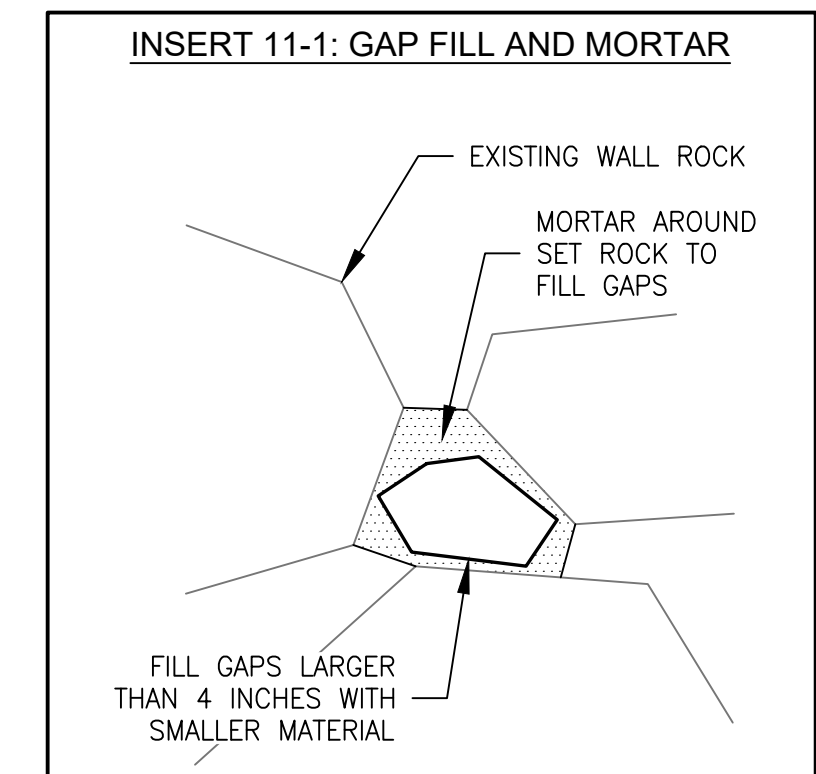

DESIGNED BY:	JCB, TPB
DRAWN BY:	JCB
CHECKED BY:	TPB
DATE:	06 NOV 2025



NOTES:	
REVISION #:	
DATE:	

UPLAND RETAINING WALL DETAIL
 100% DESIGN SHEETS
 RIPARIAN FLOODPLAIN RESTORATION
 FORMER WOODS WOOLEN MILL, HILLSBOROUGH NH

SCALE: 1" = VAR

SHEET ID: **D-2**
 SHEET NUMBER: **11** OF **11**